



## Soft starter with integrated Motor Protection, Current and Voltage control Single phase phases controlled with internal by-pass



Rated operational Voltage 230VAC  
 Frequency 45 ... 65Hz Self detecting and corrective  
 Initial Torque 20 ... 50%  
 Electronic motor protection Trip class 10  
 Adjustable I<sup>2</sup>t setting for optimal motor protection  
 Temperature protection internal  
 Ramping sequence with current limiting  
 Automatic reduction to optimum start current  
 Relay for fault signal  
 Relay for operating signal  
 LED- indications "ON": Power, ramping, bypassing, service, pause and stop.  
 LED- indications "FAULT": Over-/undercurrent, Stall, Voltage control, Frequency control, Motor connections, Main supply connections, Motor protection, Temperature control.  
 Spring clamp terminals for montage.  
 Automatic reset after failure.  
 25/35A with external start capacitor.  
 15A with internal start capacitor.

### Selection and technical specifications.

Product type	Rated operational voltage U <sub>e</sub>	EAN Nr.	Rated operational current I <sub>e</sub>	Control voltage U <sub>c</sub>
SCL 11 DA 2315BP	230VAC	5705609002954	15A AC 58b	230VAC
SCL 11 DA 2325BP	230VAC	5705609002978	25A AC 58b	230VAC
SCL 11 DA 2335BP	230VAC	5705609002985	35A AC 58b	230VAC

### Product description:

The Soft starter is single phase controlled and designed for starting and running compressor motors. The soft starter has current controlled ramping up and by-pass function.

The voltage control compensate for missing start torque at starting up ramping. The current measurement is also for I<sup>2</sup>t calculation for protection of the motor. The motor protection has to be adjusted before starting up.

The soft starter has internal by-pass relays for bypassing the semiconductors when the motor is in full speed.

Any kind of failure cause stop and the soft starter will go into service mode until the failure is reset. The soft starter has also pause mode for protecting the semiconductors against overheating. Alarm indication is provided through a red LED which signals the type of fault via a user-friendly flashing sequence.

## Customer Advantage:

Current reduction up to 65% of LRA, extend mechanical lifetime of the compressor.

Current reduction eliminates the voltage clips and light flickering.

Real RMS current measurement, for exact control of the current.

Mounting from the top and down.

Spring clamps for fast and easy mounting.

Internal motor protection (class 10 trip curve) gives reduction in cost for external motor protection and wiring.

Individual adaptation.

## Fault detections:

**Over/under current :** If the current cross the upper limit the soft starter will go into service mode to protect relays and motor. The failure is automatically reset.

: If the current is too low, the soft starter will go into service mode and stay until the failure is automatically reset.

**Motor protection :** The protection of the motor is continuously monitored and will trip according to trip class 10. The failure is automatically reset.  
(Other trip classes can be integrated).

**Stall :** If the motor is stalling the current will raise and the motor protection will close down.  
The failure is automatically reset.

**Temperature control :** If the temperature in the soft starter is detected to be under or over allowed temperature the soft starter will be in service mode and not be able to start until the temperature is in between the limits.

**Frequency sequence :** If the frequency is outside the area (45 ... 65 Hz) it will not be able to start.  
The soft starter will be in service mode until the failure is corrected and reset.

**Hardware failure :** If a hardware failure occur inside the soft starter. The soft starter will stop and go into pause mode. The failure can be reset manually but it will continue in the pause mode until the time is running out.

**Reset (push button) :** The reset will reset all failure. The pause will continue until end of time.  
The motor will start if the start signal is activated, if not it will go into service mode.

**The soft starter is active (motor not running) :**  
If the voltage drop below lower level the "Fault" alarm will occur and the soft starter will go into "Service" mode and wait until the voltage is over lower level.  
If the voltage is above upper level the "Fault" alarm will occur and the soft starter will go into "Service" mode and wait until the voltage is below upper level.

## Motor Protection Adjustment :

Adjust the motor current to  $I_n + 10\%$  as maximum.

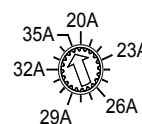
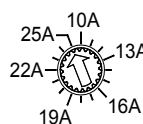
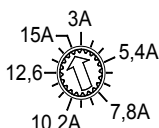

## Technical specifications:

### Supply voltage specifications:

Rated operational voltage Ue (L)	:	230VAC +15/- 15%
Rated AC frequency (self detecting and corrective)	:	45 ...65Hz
Rated insulation voltage	:	660Vrms
Undervoltage alarm	:	180VAC
Overvoltage alarm	:	260 VAC

### Control voltage specifications:

Control voltage Uc	:	230VAC +/- 15%
Control current	:	5mA
Max. control current for no operation	:	1,5W max
Drop-out voltage less than	:	90 VAC
Response time max.	:	Start 2000 msec
	:	Stop 200 msec

### Insulation specifications:

Rated insulation voltage	:	Ui 660Volt
Rated impulse withstand voltage	:	Uimp. 4 kVolt
Installation category	:	III

### Output specifications:

Utilization category	:	AC 58b with integrated by-pass contactor
Overload current profile 15/25/35A:	:	15A X-Tx: 6-1:300
	:	25A X-Tx: 6-1:300
	:	35A X-Tx: 6-1:300

### General specifications:

Initial torque	:	20 ... 50%
Motor current nominal	:	3 ... 15A; 10 ... 25A; 20 ... 35A;
Start current limit	:	35 ...45% of LRA
LRA max.	:	66/100/140 A; automatic adjusted @ motor.

### Semiconductor data:

Product type	Rated operational current	I <sup>2</sup> t	Short circuit protection
SCL 11 DA 2315BP	15A	610 A <sup>2</sup> s	max.: 35A gl/gG
SCL 11 DA 2325BP	25A	1800 A <sup>2</sup> s	max.: 63A gl/gG
SCL 11 DA 2335BP	35A	1800 A <sup>2</sup> s	max.: 63A gl/gG

### Indications (LED):

Ready mode	: The yellow LED is blinking steady slowly.
Run mode	: The yellow LED is light steady.
Pause mode	: The yellow LED is blinking steady fast.
Fault	: The yellow LED is flashing 10 times sequence and the red LED is flashing with a fault-code sequence.
Hardware failure	: The red LED is blinking with a fault-code sequence.

- Fault:**  
LED red (alarm signals via user friendly flashing sequence)
- High voltage / low voltage / Voltage (2)
  - High current / low current (3)
  - Motor protection ( $I^2t$ ) (3)
  - Stall (4)
  - By-pass relay failure (5)
  - High temperature / low temperature (6)
  - Connection failure (7)
  - Wrong frequency (8)
  - Failure in soft starter (9)

- Environment:**
- Degree of protection : IP 20
  - Pollution degree : 3
  - Operating temperature :  $-20^{\circ}$  to  $65^{\circ}\text{C}$
  - Storage temperature :  $-20^{\circ}$  to  $80^{\circ}\text{C}$
  - Terminals : Spring clamps

**Dimensions / Mounting conditions**

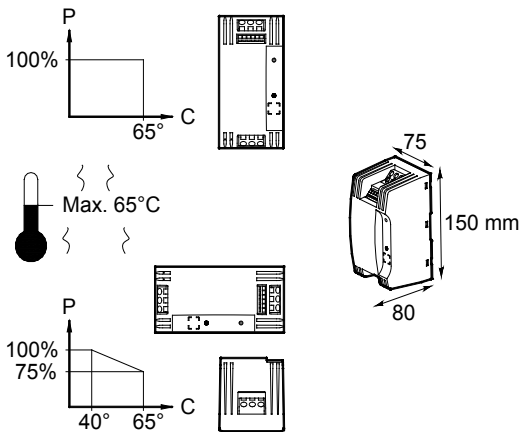

- Housing material:**  
Self-extinguishing ABS/PC UL94V0 Halogen free  
Colour: black  
Integrated DIN-Rail connection
- Terminal blocks:**  
Spring clamps main-/motor connection  $6\text{ mm}^2$   
Spring clamps control  $2,5\text{ mm}^2$

**Wiring specifications**

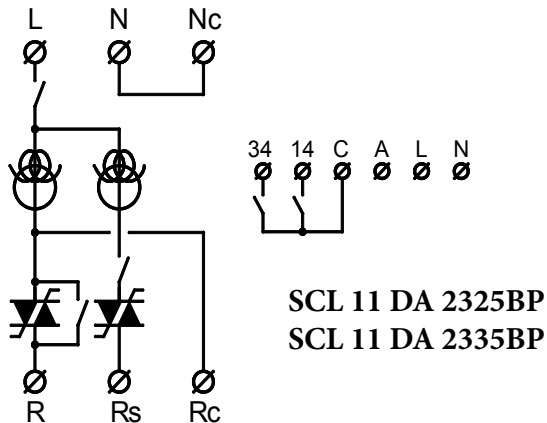

- L - N : Main supply
- R - Rs - Rc - Nc : Motor connection
- A : Control voltage 230VAC
- C - 14 : For control of start/stop function
- C - 34 : Fault signal relay
- N (A2) : Neutral
- L : Phase 230VAC

Wiring diagram page 6

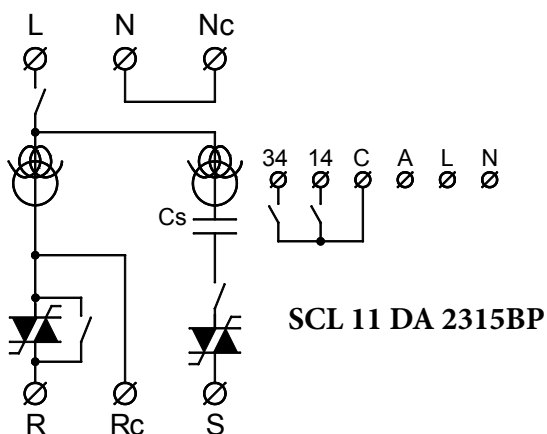

- L - N : Main supply
- R - S - Rc - Nc : Motor connection
- A : Control voltage 230VAC
- C - 14 : For control of start/stop function
- C - 34 : Fault signal relay
- N (A2) : Neutral
- L : Phase 230VAC

Wiring diagram page 6

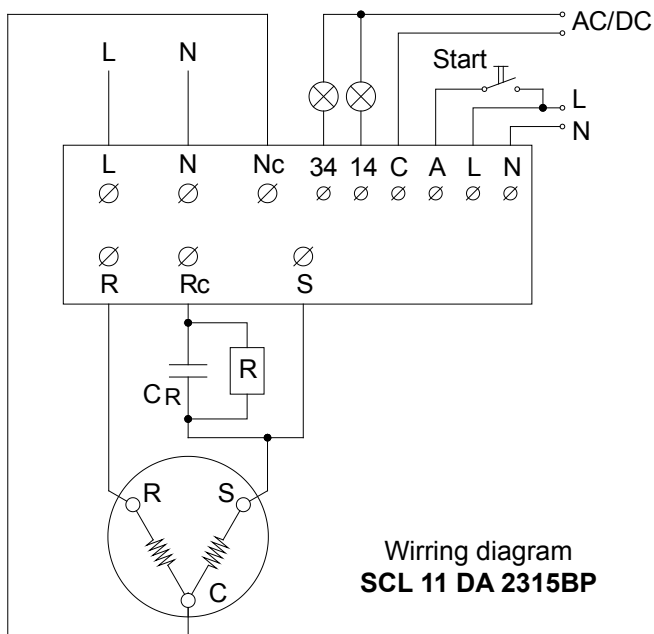

**Connections:**

L, N: Main  
 15A : R, S, Rc, Nc: Motor  
 25/35A : R, Rs, Nc, Rc: Motor

N: Neutral  
 L: Phase  
 A: Start / Stop  
 C: Common output  
 14: RUN output  
 34: Failure output

**User Control:**

Reset: Reset softstarter

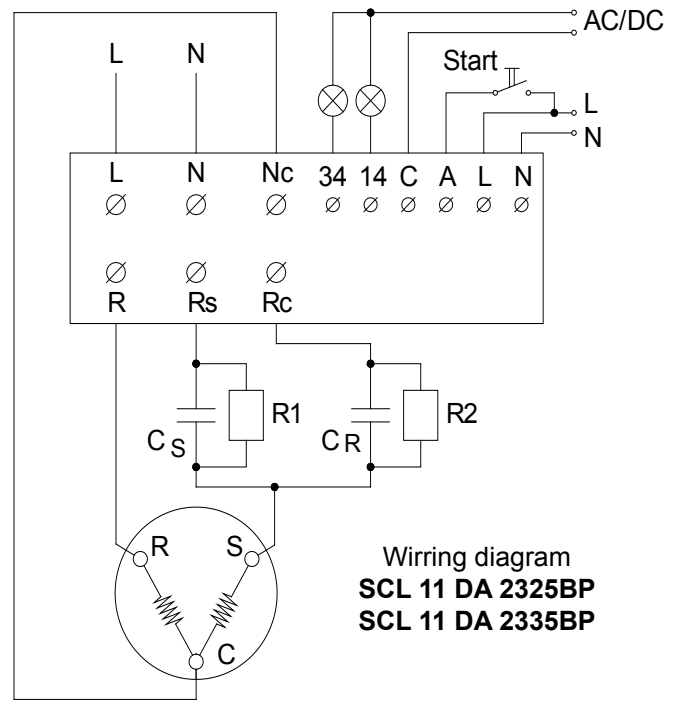

**Environmental Specifications:**

Housing: IP20  
 Mounting: Vertical, without derating  
 DIN Clip

**Supply Specifications:**

Main Voltage: 1x230Vac +15% / -15%  
 Supply Current: 6...15mA  
 Motor Protection: Class 10  
 Soft starts: 6...12 / hour

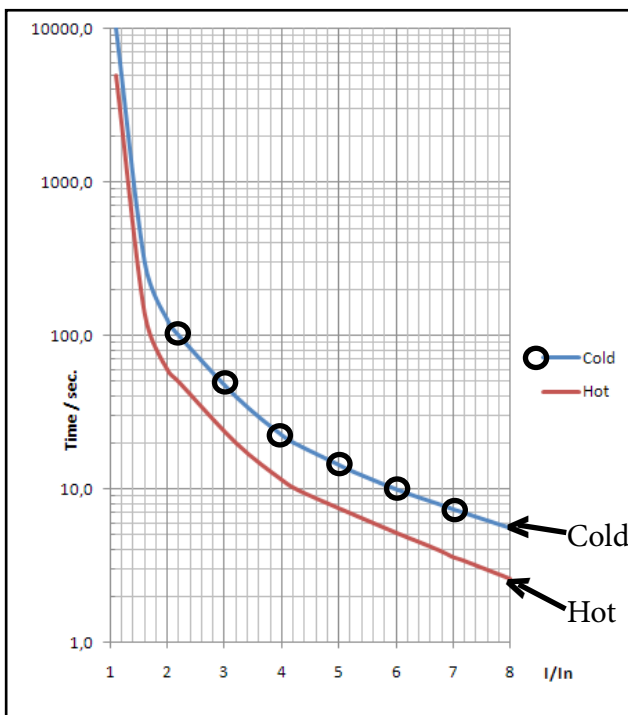

Figure: Electronic Motorprotection Class 10.

**Motor Protection:** The internal electronic motorprotection is automatically temperature compensated. The motor protections acts exactly as an external motor protection circuit breaker.

**Data for capacitors**

**Run Capacitor SCL11 DA 2325BP and SCL11 DA 2335BP:**

- Vmin: 350Vac
- Frequency: 50/60Hz
- Capacity (at 230Vac, 50Hz) : 30uF...130uF
- I(CR) min: 2A(rms)
- I(CR) max: 10A(rms)
- Discharge Resistance: Min 15Kohm / max 100Kohm

**Start capacitor:**

- Vmin: 250Vac
- Frequency: 50/60Hz
- Capacity (at 230Vac, 50Hz) : 100uF...300uF
- I(CR) min: 5A(rms)
- I(CR) max: 25A(rms)
- Discharge Resistance: Min 15Kohm / max100Kohm

**Run Capacitor SCL11 DA 2315BP:**

- Vmin: 350Vac
- Frequency: 50/60Hz
- Capacity (at 230Vac, 50Hz) : 30uF...130uF
- I(CR) min: 2A(rms)
- I(CR) max: 10A(rms)
- Discharge Resistance: Min 15Kohm / max 100Kohm

**Start capacitor:**

- Vmin: 250Vac
- Frequency: 50/60Hz
- Capacity (at 230Vac, 50Hz) : 200uF...220uF

Other capacitorer by appointment

Mode of Operation:

## Normal Conditions

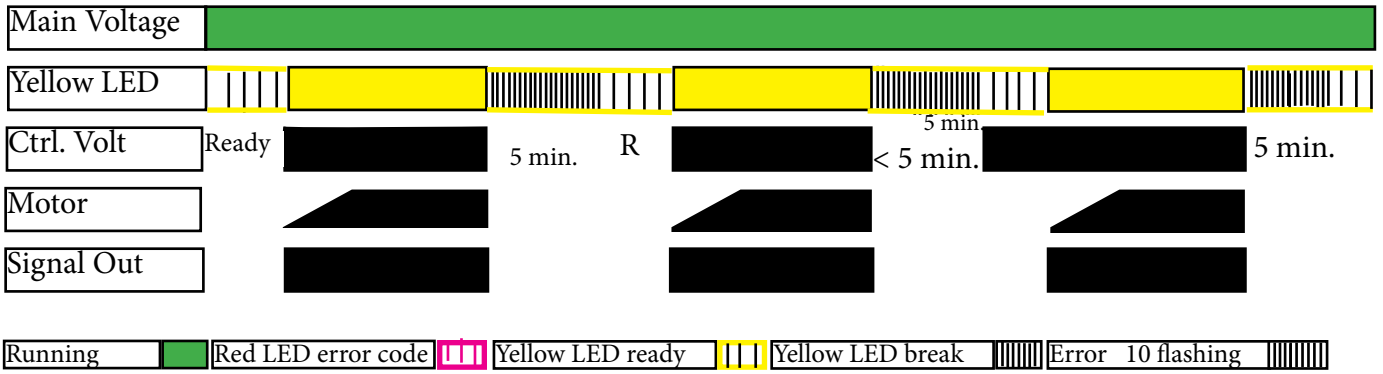

## Locked Rotor/Fault (4)

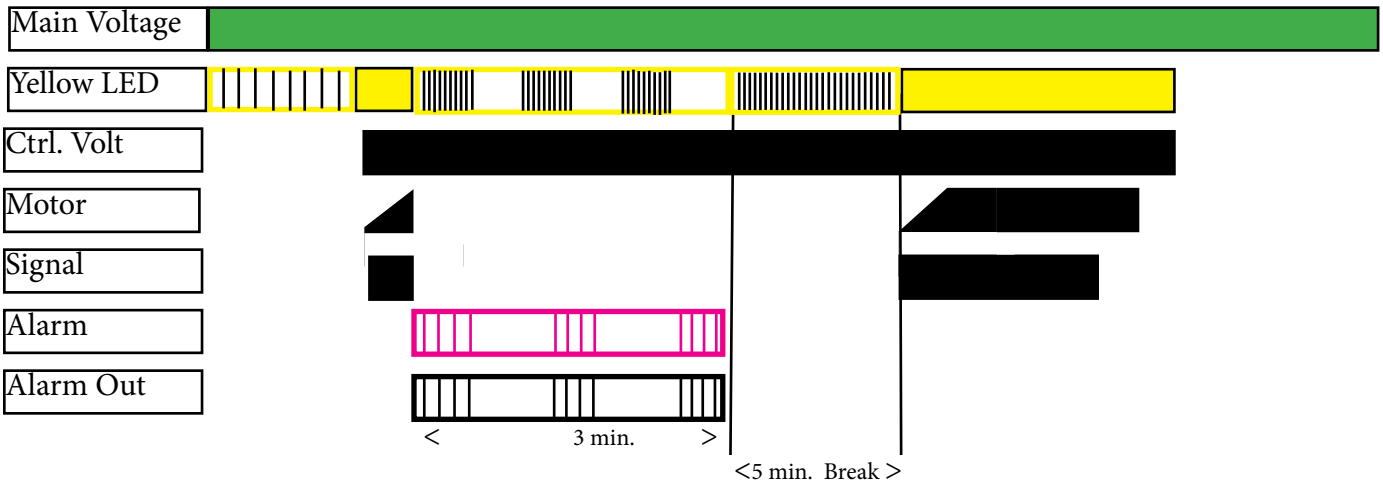

## High Temperature/Fault (6)

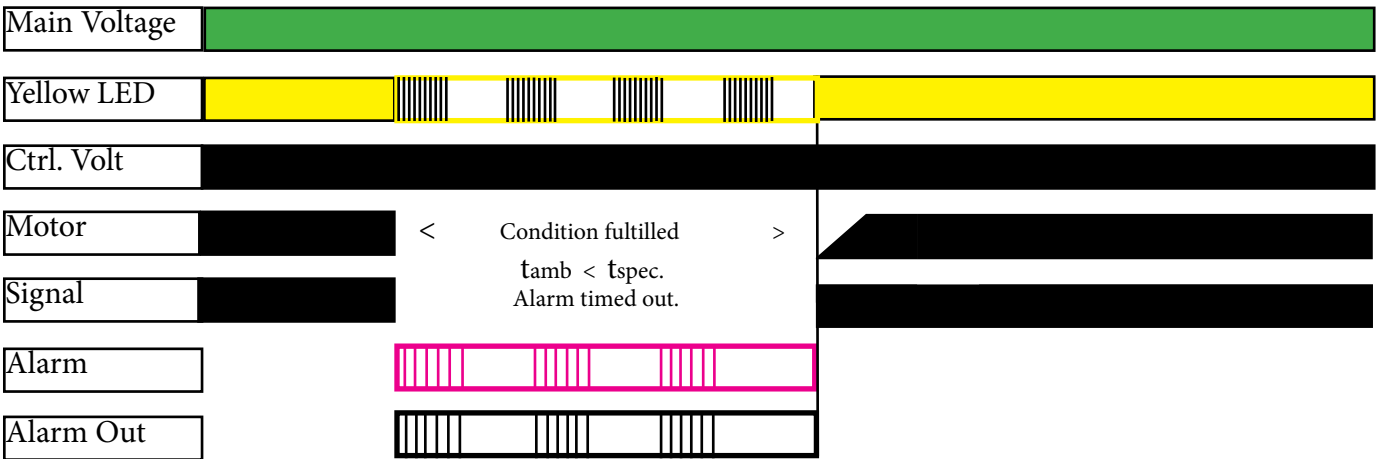

## Break/Normal

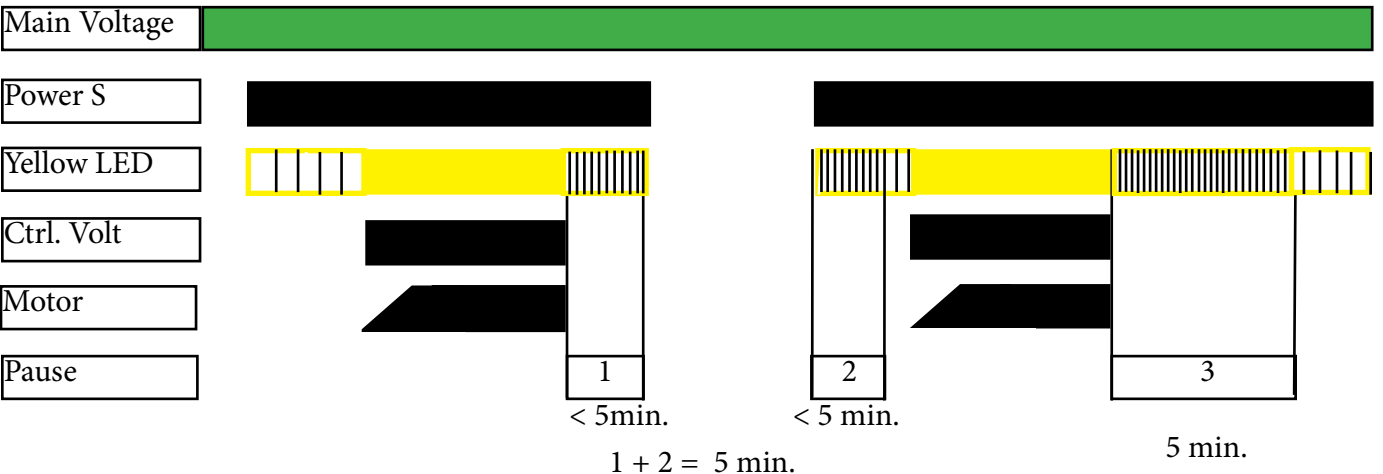

# Standards

Restrictions of hazardous substances		RoHs Compliant
CE Marking	LVD EMC: Immunity Emission	EN 60947-4-2 EN 61000-6-4 EN 61000-6-2
Electrostatic Discharge ESD	Immunity	EN 61000-4-2 8kV, Air discharge 4kV, Contact
Electrical fast transient/ Burst Immunity	Output Input	EN 61000-4-4 4 kV 4kV
Electrical Surge Immunity	Output, line to line Output, line to earth Input, line to line Input, line to earth	EN 61000-4-5 1kV 2kV 1kV 2kV
Radiated Radio Frequency Immunity		EN 61000-4-3 3V/m, 80-1000MHz
Conducted Radio Frequency Immunity Voltage dips & interference		EN 61000-4-6 3V/m, 0,15-80MHz IEC/EN 61000-4-11
Radio interference field emissions (radiated)		CISPR 11 IEC/EN 55011, ClassB
Radio interference voltage emissions (conducted)		CISPR 11 IEC/EN 55011,ClassB
Harmonics		IEC 61000-3-2
Approval		cUL ( Pending )



Eksportvej 7-9 · Laurbjerg  
DK-8870 Langaa · Denmark  
Phone: +45 70 23 49 44  
Fax: +45 70 23 49 24  
E-mail: info@ic-electronic.com  
www.ic-electronic.com