

Montering - Mounting - Montage

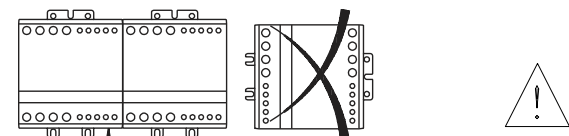

80 mm min.

DK: Hvis enheden er monteret vandret, skal driftsstrømmen reduceres med 50%
Køleplade skal holdes ren.
Luftstrømmen må ikke blokeres

UK: If the unit is mounted horizontally the current must be derated by 50%
Keep heatsink clean. Airflow must not be blocked

DE: Falls Einheit horizontal montiert wird, muss der Strom um 50% reduziert werden.
Kühlflächen freihalten. Luftstrom muss ungehindert fließen

30 mm min.

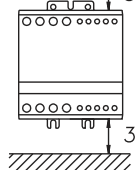

30 mm min.

Dimensioner - Dimensions - Dimensionen

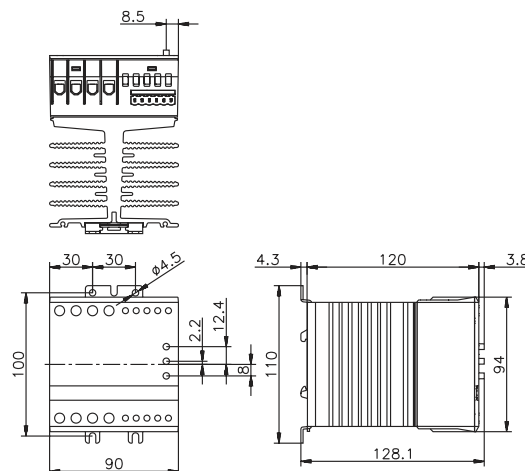

Forbindelse - Wiring - Verdrahtung

75°C
Wire / Kabel

mm²

mm²



1 x 1.5 - 6

1 x 0.5 - 1.5



2 x 1.5 - 6

2 x 0.5 - 0.75

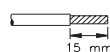

1 x 1.5 - 6

1 x 0.5 - 1.5



2 x 1.5 - 6

2 x 0.5 - 1.5

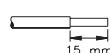

1 x 1 - 10

1 x 0.5 - 1.5



2 x 1 - 6

2 x 0.5 - 1.5

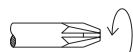

Pozidrive 2
1.2 Nm max.



6mm
1.2 Nm max.

3 mm
0.4 Nm max.

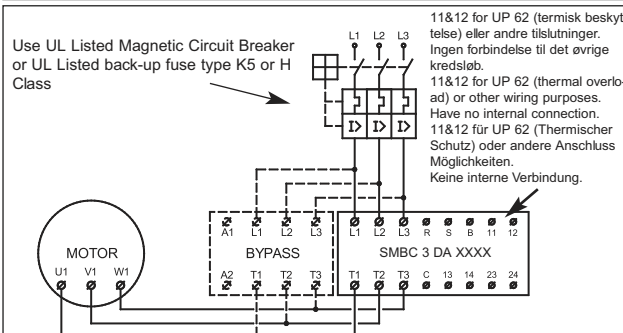
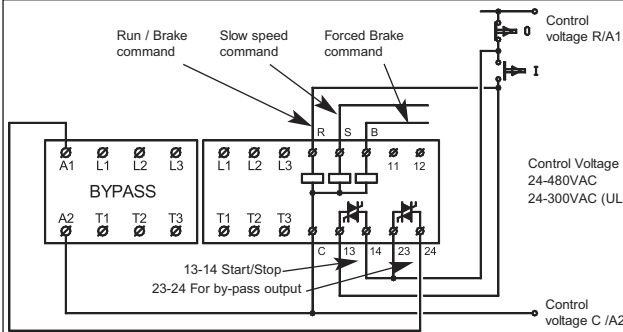

- **Vigtigt** (Overhold max skruedrejningsmomenter)
- **Important:** (Observe the maximum screw torque limits)
- **Wichtig:** (Max. Drehmoment beachten)

DK: Hvis beskyttet med sikringer, se specifikationer i datablad.
UK: If protection with fuses, see recommendation in data-sheet.
DE: Falls Sicherungen verwendet werden, Empfehlungen im Datenblatt beachten.

This product has been designed for class A equipment. Use of the product in domestic environments may cause radio interference, in which case the user may be required to employ additional mitigation methods.
Do not connect power factor correction capacitors to the output.

Funktions / Functional / Funktionsdiagram

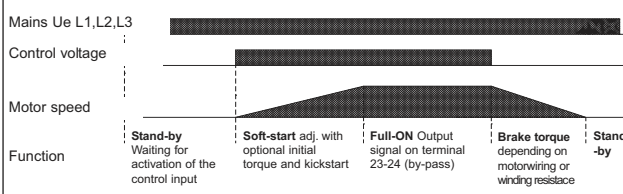

UL: Use thermal overload protection as required by the National Electric Code.
UL: SMC XX DBP. When protected by a non-time delay K5 or H Class fuse, rated 266 % of motor FLA, this device is rated for use on a circuit capable of delivering not more than 5,000 rms. symmetrical amperes, 600 V maximum.
Maximum surrounding temperature 40°C.

DK: Se specifikationer i datablad UK: See recommendation in datasheet DE: Empfehlungen im Datenblatt beachten

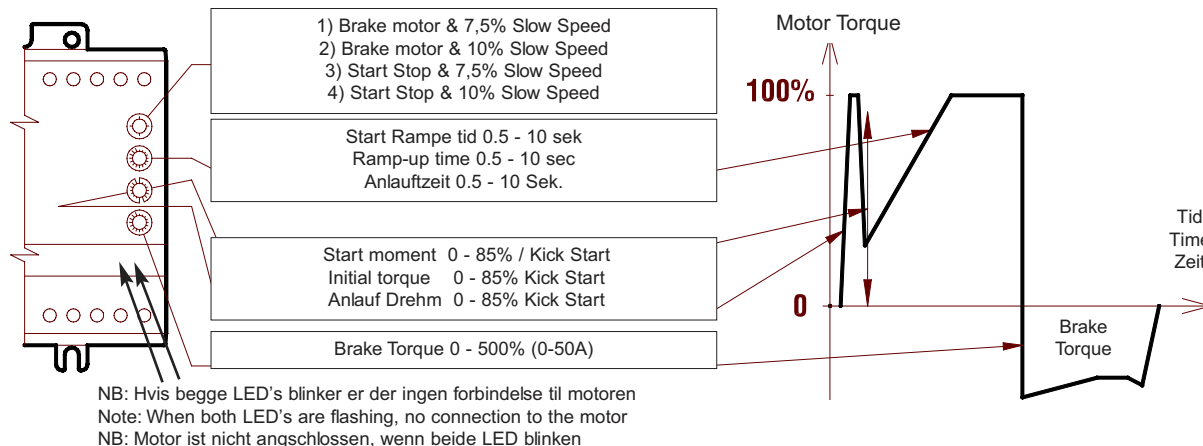
Indstilling - Settings - Einstellungen

Bemærkninger - Remarks - Bemerkungen

<p>DK</p> <ul style="list-style-type: none"> - Anvend 2 mm x 0.5 mm skruetrækker - Vær forsigtig ikke at indstille drejekontakterne imellem klik. - Motor Controlleren aflæser tid og moment justeringen i stop tilstand. - Gentagne start forsøg kan resultere i at motoroverbelastningsrelæet aktiveres <p>NB: Indstil Brake Torque til 1 før tilslutning af driftsspænding. Ved større motorer kan for høj indstilling medføre komponent skader</p>	<p>UK</p> <ul style="list-style-type: none"> - Use 2 mm x 0.5 mm screwdriver - Make sure that the switches click into position, otherwise time and torque settings will not be correct. - The motor controller will read time and torque settings in the off state - Repeated starts may trip the motor protection relay <p>NB: Adjust Brake Torque to 1 before mains is connected. For larger motors a too high brake current can lead to component damages</p>	<p>DE</p> <ul style="list-style-type: none"> -Schraubenzieher 2 mm x 0.5 mm verwenden - Schalter müssen einrasten, um korrekte Funktion zu gewährleisten. - Eingestellte Werte werden im ausgeschalteten Zustand abgelesen. - Mehrfach Starts kann Motorschutzrelais auslösen <p>Vor Anschluss der Betriebsspannung.</p> <p>NB: Break Torque auf 1 stellen. Bei grösseren Motoren kann eine zu hohe Einstellung Schäden an den Komponenten verursachen</p>
---	---	---

Start moment indstilling - Initial torque setting - Einstellung der Startleistung

	<p>DK</p> <ol style="list-style-type: none"> 1) Indstil Ramp-Up til max. 2) Indstil Brake Torque til 1 3) Indstil Initial Torque til min. 4) Påtryk signalspændingen i et par sekunder, hvis ikke motor akslen roterer øjeblikkelig efter start, juster Initial Torque en trin op. Gentag indtil motor akslen roterer øjeblikkelig efter start. 	<p>UK</p> <ol style="list-style-type: none"> 1) Set Ramp-Up switch to max. 2) Set Brake Torque switch to 1 3) Set Initial Torque switch to min. 4) Apply control voltage for a few seconds. If the load does not rotate immediately increase the Initial Torque one step and try again. Repeat until the load starts to rotate immediately on start up. 	<p>DE</p> <ol style="list-style-type: none"> 1) Ramp-Up Schalter auf max. stellen 2) Brake Torque Schalter auf 1 stellen 3) Initial Torque Schalter auf min. stellen 4) Steuerspannung einige Sekunden betätigen. Falls Motor nicht sofort anläuft, Initial Torque schrittweise erhöhen bis Motor anläuft
	<p>DK Hvis Initial Torque justeringen ikke er tilstrækkelig til at starte motoren, er det nødvendigt at anvende Kick-start</p> <ol style="list-style-type: none"> 1) Indstil Initial Torque til min. (Kick-Start) 2) Indstil Ramp-up til max. 3) Påtryk signalspændingen i et par sekunder, hvis belastningen stopper, umiddelbart efter Kick-Start, juster Initial Torque et trin op. Gentag indtil motor akslen fortsætter med at rotere efter Kick-Start. 	<p>UK If the max. Initial Torque settings is not sufficient to start the motor it is necessary to use Kick-start.</p> <ol style="list-style-type: none"> 1) Set Initial Torque switch to min. (Kick-Start) 2) Set Ramp-Up switch to max. 3) Apply control voltage for a few seconds. If the load stops right after the Kick-Start, increase the Initial Torque one step. Repeat until the load starts to rotate after the Kick-Start. 	<p>DE Falls Initial-torque max. Einstellung nicht ausreichend um den Motor zu starten, muss Kick-start verwendet werden.</p> <ol style="list-style-type: none"> 1) Initial Torque auf min. stellen. Kick-Start 2) Ramp-Up auf max. stellen 3) Steuerspannung einige Sekunden betätigen. Falls der Motor sofort nicht anläuft, Initial Torque schrittweise erhöhen, bis der Motor sofort nach dem Kick-Start anläuft.

Bremsemoment indstilling - Brake Torque adjustment - Bremstrommoment einstellung

	<p>DK</p> <ol style="list-style-type: none"> 1) Indstil Ramp-Up til max og motoren starter. 2) Juster derefter Ramp-Up tiden indtil motoren starter som ønsket 	<p>UK</p> <ol style="list-style-type: none"> 1) Set Ramp-Up switch to max. and the motor starts. 2) Adjust the Ramp-Up time to the desired starting time. 	<p>DE</p> <ol style="list-style-type: none"> 1) Ramp-Up Schalter auf gewünschten Wert einstellen. 2) Ramp-Up Zeit solange einstellen, bis der Motor anläuft.
	<p>1) Juster Brake Torque indtil den ønskede bremsetid opnås. NB. Hvis bremse moment indstillingen er for lav eller for høj vil den automatiske stop detektering ikke fungere.</p>	<p>1) Adjust the Brake Torque until the desired stop time is obtained. NB. Note that if the braking torque setting is too high or too low the automatic stop detection will not function</p>	<p>1) Brake Torque einstellen, bis die gewünschte Bremszeit erreicht ist. NB. Fall die Einstellung der Bremsleistung zu niedrig oder zu hoch ist, wird der Automatische Stop nicht funktionieren.</p>