

Absolute encoders - singleturn

Standard
SIL2/PLd, optical

Sendix SIL 5853FS2 / 5873FS2 (shaft / hollow shaft)

SSI/BiSS + SinCos



The absolute singleturn encoders 5853FS2 and 5873FS2 of the Sendix SIL family are suited for use in safety-related applications up to SIL2 according to EN 61800-5-2 or PLd to EN ISO 13849-1.

The extra strong Safety-Lock™ design interlocked bearings, the high integration density of the components based on OptoASIC technology and the rugged die-cast housing make these devices ideal also for demanding applications outdoors up to IP65.



Safety-Lock™



High rotational speed



Temperature range



High protection level



High shaft load capacity



Shock / vibration resistant



Magnetic field proof



Reverse polarity protection

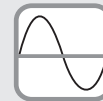

SinCos



Optical sensor

Functional Safety

- Encoder with individual certificate from IFA / TÜV.
- Suitable for applications up to SIL2 acc. to EN 61800-5-2.
- Suitable for applications up to PLd acc. to EN ISO 13849-1.
- SSI or BiSS interface with incremental SinCos tracks with 2048 ppr.
- Certified mechanical mounting + electronic.

Flexible

- Shaft and hollow shaft versions.
- Cable and connector variants.
- Various mounting options available.

Order code
Shaft version

8.5853FS2 . **1XXX** . **XX2X**
Type a b c d e f g

a Flange

1 = clamping flange, IP65, ø 58 mm [2.28"]

b Shaft (ø x L)

2 = 10 x 20 mm [0.39 x 0.79"], with flat
A = 10 x 20 mm [0.39 x 0.79"], with feather key

c Interface / power supply

3 = SSI, BiSS + 2048 ppr. SinCos / 5 V DC
4 = SSI, BiSS + 2048 ppr. SinCos / 10 ... 30 V DC

d Type of connection

1 = axial cable, 1 m [3.28'] PVC
A = axial cable, special length PVC *)
2 = radial cable, 1 m [3.28'] PVC
B = radial cable, special length PVC *)
3 = axial M23 connector, 12-pin
4 = radial M23 connector, 12-pin

*) Available special lengths (connection types A, B):
2, 3, 5, 8, 10, 15 m [5.56, 9.84, 16.40, 26.25, 32.80, 49.21']
order code expansion .XXXX = length in dm
ex.: 8.5853FS2.124A.G322.0030 (for cable length 3 m)

e Code

B = SSI, binary
C = BiSS, binary
G = SSI, gray

f Resolution ¹⁾

A = 10 bit
1 = 11 bit
2 = 12 bit
3 = 13 bit
4 = 14 bit
7 = 17 bit

g Options (service)

1 = no option
2 = status LED
3 = SET button and status LED

Optional on request

- Ex 2/22 ²⁾
- other resolutions

1) Resolution, preset value and count direction are factory-programmable.
2) For the cable connection type, cable material PUR.

Absolute encoders - singleturn

Standard SIL2/PLd, optical	Sendix SIL 5853FS2 / 5873FS2 (shaft / hollow shaft)	SSI/BiSS + SinCos
---------------------------------------	--	--------------------------

Order code Hollow shaft	8.5873FS2 . X X X X . X X 2 X <small>Type</small> <small>a</small> <small>b</small> <small>c</small> <small>d</small> <small>e</small> <small>f</small> <small>g</small>
------------------------------------	--

<p>a <i>Flange</i> 9 = with torque stop, flexible, IP65 A = with torque stop set, rigid, IP65 B = with stator coupling, IP65, ø 63 mm [2.48"]</p> <p>b <i>Through hollow shaft</i> 3 = ø 10 mm [0.39"] 4 = ø 12 mm [0.47"] 5 = ø 14 mm [0.55"] <i>Tapered shaft</i> K = ø 10 mm [0.39"]</p> <p>c <i>Interface / power supply</i> 3 = SSI, BiSS + 2048 ppr. SinCos / 5 V DC 4 = SSI, BiSS + 2048 ppr. SinCos / 10 ... 30 V DC</p>	<p>d <i>Type of connection</i> 2 = radial cable, 1 m [3.28'] PVC B = radial cable, special length PVC *) E = tangential cable, 1 m [3.28'] PVC F = tangential cable, special length PVC *) 4 = radial M23 connector, 12-pin *) Available special lengths (connection types B, F): 2, 3, 5, 8, 10, 15 m [5.56, 9.84, 16.40, 26.25, 32.80, 49.21'] order code expansion .XXXX = length in dm ex.: 8.5873FS3.B44B.G322.0030 (for cable length 3 m)</p> <p>e <i>Code</i> B = SSI, binary C = BiSS, binary G = SSI, gray</p>	<p>f <i>Resolution ¹⁾</i> A = 10 bit 1 = 11 bit 2 = 12 bit 3 = 13 bit 4 = 14 bit 7 = 17 bit</p> <p>g <i>Options (service)</i> 1 = no option 2 = status LED 3 = SET button and status LED</p> <p style="text-align: right;"><i>Optional on request</i> - Ex 2/22 (not for type of connection E, F) ²⁾ - other resolutions</p>
---	---	--

Accessories	Order no.
EMC shield terminal for top-hat rail mounting	8.0000.4G06.0000
Screw retention Loctite 243, 5 ml	8.0000.4G05.0000
Bellows coupling, safety-oriented	You will find an overview of our couplings for Sendix SIL shaft encoders in the accessories section or under www.kuebler.com/accessories .
Safety modules Safety-M compact / modular	You will find an overview of our systems and components for Functional Safety and the corresponding software in the safety technology section or under www.kuebler.com/safety .
LED SSI display 570 / 575	Electronic position display up to 32 bit. You will find an overview in the accessories section or under www.kuebler.com/position_display .

Further accessories can be found in the accessories section or in the accessories area of our website at: www.kuebler.com/accessories.

Connection technology	Order no.	
Cordset, pre-assembled	M23 female connector with coupling nut, 12-pin single-ended, 2 m [6.56'] PVC cable ³⁾	8.0000.6901.0002.0031
	M23 female connector with coupling nut, 12-pin M23 male connector with external thread, 12-pin 2 m [6.56'] PVC cable ³⁾	8.0000.6905.0002.0032
Connector, self-assembly (straight)	M23 female connector with coupling nut, 12-pin	8.0000.5012.0000

Additional connectors can be found in the connection technology section or in the connection technology area of our website at: www.kuebler.com/connection_technology.

1) Resolution, preset value and count direction are factory-programmable.
2) For the cable connection type, cable material PUR.
3) Other lengths available.

Absolute encoders - singleturn

Standard SIL2/PLd, optical	Sendix SIL 5853FS2 / 5873FS2 (shaft / hollow shaft)	SSI/BiSS + SinCos
--------------------------------------	--	--------------------------

Technical data

Notes regarding "Functional Safety"

These encoders are suitable for use in safety-related systems up to SIL2 acc. to EN 61800-5-2 and PLd to EN ISO 13849-1 in conjunction with controllers or evaluation units, which possess the necessary functionality.

Additional functions can be found in the operating manual.

Safety characteristics	
Classification	PLd / SIL2
System structure	2 channel (Cat. 3)
PFH_d value¹⁾	$2.16 \times 10^{-8} \text{ h}^{-1}$
Mission time / Proof test interval	20 years
Relevant standards	EN ISO 13849-1:2008 EN ISO 13849-2:2013 EN 61800-5-2:2007

Electrical characteristics	
Power supply	5 V DC ($\pm 5\%$) or 10 ... 30 V DC
Current consumption (no load)	5 V DC max. 70 mA 10 ... 30 V DC max. 45 mA
Reverse polarity protection of the power supply	yes
Short circuit proof outputs	yes ²⁾
UL approval	file no. E224618
CE compliant acc. to	EMC guideline 2014/30/EU Machinery directive 2006/42/EC RoHS guideline 2011/65/EU

Mechanical characteristics	
Maximum speed shaft version	up to 70°C [158°F] 12000 min ⁻¹ , 10000 min ⁻¹ (continuous) up to T _{max} 8000 min ⁻¹ , 5000 min ⁻¹ (continuous)
Maximum speed hollow shaft version	up to 70°C [158°F] 9000 min ⁻¹ , 6000 min ⁻¹ (continuous) up to T _{max} 6000 min ⁻¹ , 3000 min ⁻¹ (continuous)
Starting torque - at 20°C [68°F]	shaft version < 0.01 Nm hollow shaft version < 0.03 Nm
Mass moment of inertia	shaft version $4.0 \times 10^{-6} \text{ kgm}^2$ hollow shaft version $7.0 \times 10^{-6} \text{ kgm}^2$
Insertion depth for shaft	hollow shaft version min. 34 mm [1.34"]
Load capacity of shaft	radial 80 N axial 40 N
Weight	approx. 0.45 kg [15.87 oz]
Protection acc. to EN 60529	IP65
Working temperature range	-40°C ... +90°C [-40°F ... +194°F] ³⁾
Material	shaft / hollow shaft stainless steel flange aluminum housing zinc die-cast cable PVC (PUR for Ex 2/22)
Shock resistance acc. to EN 60068-2-27	500 m/s ² , 11 ms
Vibration resistance acc. to EN 60068-2-6	200 m/s ² , 10 ... 150 Hz

1) The specified value is based on a diagnostic coverage of 90 %, that must be achieved with an encoder evaluation unit.
The encoder evaluation unit must meet at least the requirements for SIL2.

EMC	
Relevant standards	EN 55011 class B :2009 / A1:2010 EN 61000-6-3:2007 / A1:2011 EN 61000-6-2:2005

SSI interface	
Output driver	RS485 transceiver type
Permissible load / channel	max. +/- 20 mA
Signal level	HIGH typ. 3.8 V LOW at I _{Load} = 20 mA typ. 1.3 V
Resolution	10 ... 14 bit and 17 bit
Code	binary or gray
SSI clock rate	50 kHz ... 2 MHz
Data refresh rate	ST resolution ≤ 14 bit ≤ 1 μs ST resolution ≥ 15 bit 4 μs
Monoflop time	≤ 15 μs
Note: If the clock starts cycling within the monoflop time, a second data transfer starts with the same data. If the clock starts cycling after the monoflop time, the data transfer starts with the new values. The update rate is dependent on the clock speed, data length and monoflop-time.	

BiSS interface	
Output driver	RS485 transceiver type
Permissible load / channel	max. +/- 20 mA
Signal level	HIGH typ. 3.8 V LOW at I _{Load} = 20 mA typ. 1.3 V
Resolution	10 ... 14 bit and 17 bit
Code	binary
Clock rate	up to 10 MHz
Max. update rate	< 10 μs, depends on the clock rate and the data length
Data refresh rate	ST resolution ≤ 14 bit ≤ 1 μs ST resolution 17 bit 2.4 μs
Note: <ul style="list-style-type: none"> - bidirectional, factory programmable parameters are: resolution, code, direction, alarms and warnings - CRC data verification 	

SinCos interface	
Max. frequency -3dB	400 kHz
Signal level	1 V _{pp} ($\pm 10\%$)
Short circuit proof	yes ²⁾
Pulse rate	2048 ppr

LED	
The optional LED (red) serves to display various alarm or error messages. In normal operation the LED is OFF.	
If the LED is ON (status output LOW) this indicates: <ul style="list-style-type: none"> - sensor error, singleturn or multiturn (soiling, glass breakage etc.) - LED error, failure or ageing - Over- or under-temperature 	
In the SSI mode, the fault indication can only be reset by switching off the power supply to the device.	

2) Short circuit to 0 V or to output, one channel at a time, power supply correctly applied.
3) Cable version: -30°C ... +90°C [-22°F ... +194°F].

Absolute encoders - singleturn

Standard SIL2/PLd, optical	Sendix SIL 5853FS2 / 5873FS2 (shaft / hollow shaft)	SSI/BiSS + SinCos
---------------------------------------	--	--------------------------

SET input or SET button	
Input	HIGH active
Input type	comparator
Signal level	HIGH min: 60 % of +V, max: +V LOW max: 25 % of +V (power supply)
Input current	< 0.5 mA
Min. pulse duration (SET)	10 ms
Timeout after SET signal	14 ms

The encoder can be set to zero at any position by means of a HIGH signal on the SET input or by pressing the optional SET button (with a pencil, ball-point pen or similar). Other preset values can be factory-programmed. The SET input has a signal delay time of approx. 1 ms. Once the SET function has been triggered, the encoder requires an internal processing time of approx. 15 ms before the new position data can be read. During this time the LED is ON.

If this input is not used, it should be connected to 0 V (Encoder ground GND) in order to avoid interferences.

DIR input	
Direction input: A HIGH signal switches the direction of rotation from the default cw to ccw. This function can also be factory-programmed to be inverted. If DIR is changed when the device is already switched on, then this will be interpreted as an error. The LED will come ON and the status output will switch to LOW.	
If this input is not used, it should be connected to 0 V (Encoder ground GND) in order to avoid interferences.	
Response time (DIR input)	1 ms

Power-ON	
After Power-ON the device requires a time of approx. 150 ms before valid data can be read.	
Hot plugging of the encoder should be avoided.	

Terminal assignment

Interface	Type of connection	Cable (isolate unused cores individually before initial start-up)													
		Signal:	0 V	+V	C+	C-	D+	D-	SET	DIR	A	\bar{A}	B	\bar{B}	\perp
3, 4	1, 2, A, B, E, F	Core color:	WH	BN	GN	YE	GY	PK	BU	RD	BK	VT	GY-PK	RD-BU	shield

Interface	Type of connection	M23 connector, 12-pin													
		Signal:	0 V	+V	C+	C-	D+	D-	SET	DIR	A	\bar{A}	B	\bar{B}	\perp
3, 4	3, 4	Pin:	1	2	3	4	5	6	7	8	9	10	11	12	PH

- +V: Encoder power supply +V DC
- 0 V: Encoder power supply ground GND (0 V)
- C+, C-: Clock signal
- D+, D-: Data signal
- SET: Set input
- DIR: Direction input
- A, \bar{A} : Cosine signal
- B, \bar{B} : Sine signal
- PH \perp : Plug connector housing (shield)

Top view of mating side, male contact base

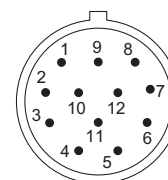

M23 connector, 12-pin

Absolute encoders - singleturn

**Standard
SIL2/PLd, optical**

Sendix SIL 5853FS2 / 5873FS2 (shaft / hollow shaft)

SSI/BiSS + SinCos

Dimensions shaft version

Dimensions in mm [inch]

Clamping flange, \varnothing 58 [2.28]

Flange type 1 with shaft type 2

(drawing with cable)

- 1 3 x M3, 6 [0.24] deep
- 2 3 x M4, 8 [0.32] deep

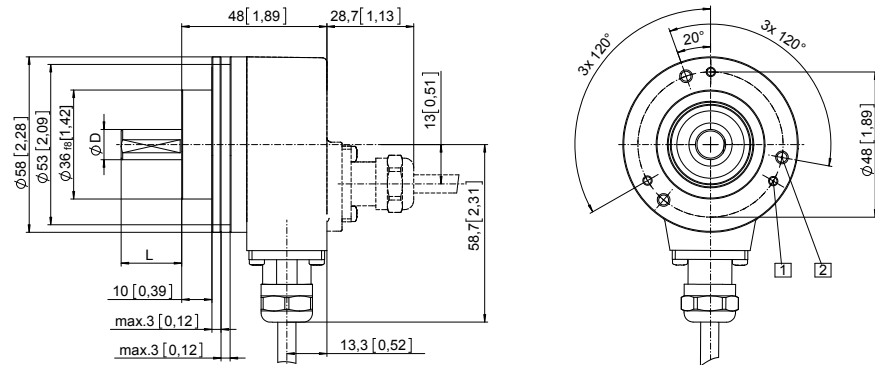

D	Fit	L
10 [0.39]	f7	20 [0.79]

Clamping flange, \varnothing 58 [2.28]

Flange type 1 with shaft type A

(drawing with M23 connector)

- 1 3 x M3, 6 [0.24] deep
- 2 3 x M4, 8 [0.32] deep
- 3 Feather key DIN 6885 - A - 3x3x6

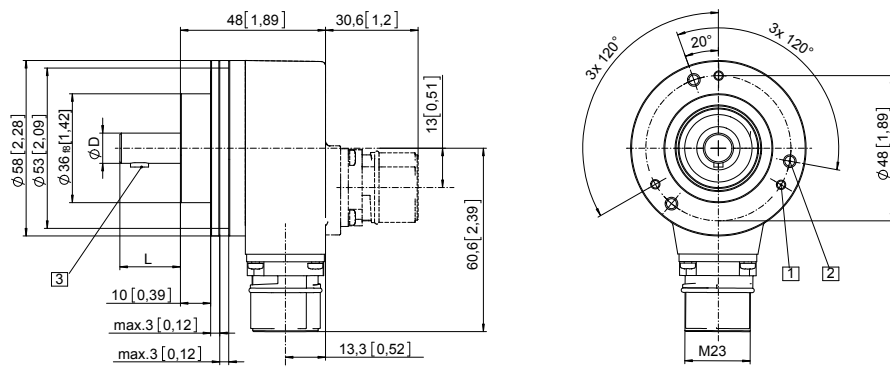

D	Fit	L
10 [0.39]	f7	20 [0.79]

Absolute encoders - singleturn

Standard
SIL2/PLd, optical

Sendix SIL 5853FS2 / 5873FS2 (shaft / hollow shaft)

SSI/BiSS + SinCos

Dimensions hollow shaft version

Dimensions in mm [inch]

Flange with stator coupling, \varnothing 63 [2.48]

Flange type B

Through hollow shaft

(drawing with M23 connector)

1 SW 3, recommended torque for the clamping ring 2.5 Nm

2 For (4x) M3 screw

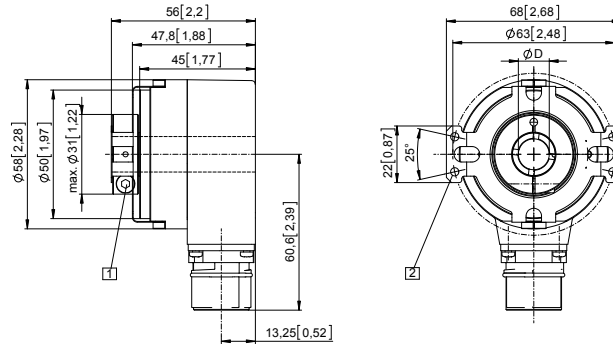

D	Fit
10 [0.39]	H7
12 [0.47]	H7
14 [0.55]	H7

Flange with stator coupling, \varnothing 63 [2.48]

Flange type B

Tapered shaft

(drawing with tangential cable outlet)

1 For (4x) M3 screw

2 Status LED

3 SET button

4 SW 4

