

- Slip Rings
- Optical Fibre Transmission Modules
- Cables, Connectors and pre-assembled Cordsets
- Functional Safety

## Our Pulses for Innovations



The Kübler Group belongs today to the leading specialists worldwide in the fields of position and motion sensors, functional safety, counting and process technology and transmission technology.

Founded in the year 1960 by Fritz Kübler, the family business is now led by the next generation of Gebhard and Lothar Kübler.

Ten international group members and distributors in more than 50 countries offer local product know-how, service and advice throughout the world.

Innovative product and sector solutions, as well as solutions for functional safety and a high level of service, are the reasons behind our global success.

The strict focus on quality ensures the highest levels of reliability and a long service life for our products in the field.

Over 450 dedicated people worldwide make this success possible and ensure that customers can continue to place their trust in our company.



# Kübler Service for worldwide Planning Reliability



## Sample and Repair Service

We manufacture samples of special designs or according to customer specification within shortest time. We carry out repair work reliably within a maximum of 5 days.



## 10 by 10

We will manufacture and deliver 10 encoders within 10 working days (365 days a year - with the exception of 24th Dec. until 2nd Jan.)



## Kübler online – [www.kuebler.com](http://www.kuebler.com)

- Up-to-date product and company information
- Product finder – the selection tool that helps you finding quickly the suitable product
- Download service for CAD data, software, operating instructions, certificates and catalogues
- You will find comprehensive information about the basic technical knowledge relating to our products on our homepage: [www.kuebler.com/basics](http://www.kuebler.com/basics)



## 48 h Express Service

We can process your order within 48 hours; we can ship stock items the same day.

- Simplified orders
- Calculable delivery
- Flexible use of small batch sizes



## Safety Services

- Adapted service packages
- Individual customer solutions



## Tailor-made Solutions – Kübler Design System (KDS) OEM Products and Systems (OPS)

We develop jointly with our customers product and engineering solutions for customer-specific products, integrated drive solutions, up to complete systems (sensors, electronics and mechanics).



## Service-Center / Technical Hotline

Whatever your needs, advice, analysis or support for the installation, Kübler is present on site all over the world with its Service Center.

Kübler Germany ..... +49 7720 3903 952  
 Kübler France ..... +33 3 89 53 45 45  
 Kübler Italy ..... +39 026 423 345  
 Kübler Poland ..... +48 61 84 99 902

Kübler Turkey ..... +90 216 999 9791  
 Kübler China ..... +86 10 8471 0818  
 Kübler India ..... +91 8600 147 280  
 Kübler USA ..... +1 855 583 2537

# Our Product Portfolio



## Position and Motion Sensors

- Incremental and Absolute Encoders
- Linear Measuring Technology
- Inclinometers
- Connection Technology

## Transmission Technology

- Slip Rings
- Optical Fibre Signal Transmission Modules
- Cables, Connectors and pre-assembled Cordsets

## Functional Safety

- Encoders certified up to SIL3/PlE
- Modules for safe Drive Monitoring
- System Solutions for safe processing of Safety Sensors
- Adapted Service Packages

## Counters and Process Devices

- Pulse Counters and Preset Counters
- Hour Meters and Timers
- Frequency Meters and Tachometers
- Combination Time and Energy Meters
- Position Displays
- Process Displays and Controllers for Temperature, Analogue Signals and Strain-Gauge
- Setpoint Adjuster

## We offer Solutions for the following Industries:



The high performance level and reliability of the Kübler products are based on our long experience in these demanding application sectors. Learn more about our application-specific solutions under:

[www.kuebler.com/industries](http://www.kuebler.com/industries)

# Transmission Technology 2015

<b>Table of contents</b>	
<b>Product Overview / Basics</b>	<b>5</b>
<b>Slip Rings</b>	<b>19</b>
<b>Optical Fibre Signal Transmission Modules</b>	<b>31</b>
<b>Connection Technology</b>	<b>39</b>
<b>Addresses</b>	<b>83</b>

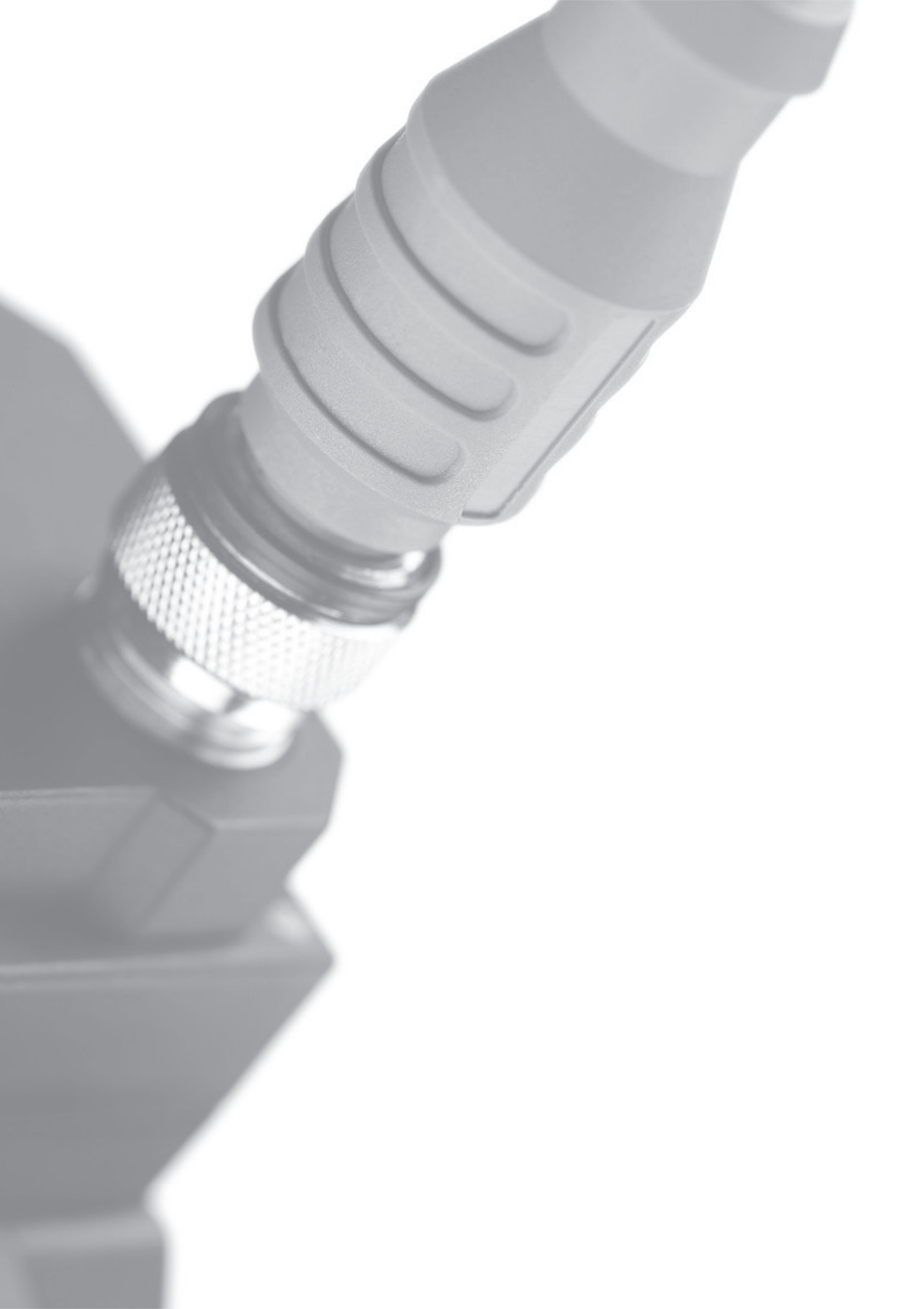

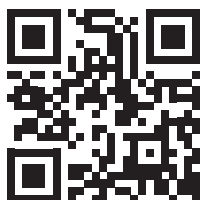

		Page
<b>Product overview</b>		<b>6</b>
<hr/>		
<b>Technical basics</b>	Slip rings	<b>10</b>
	Optical fibre transmission modules	<b>15</b>
	Cables and connectors	<b>16</b>

You will find comprehensive information about the basic technical knowledge relating to our products on our homepage, at the address [www.kuebler.com/basics](http://www.kuebler.com/basics)



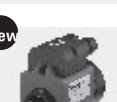

## Product overview

### Slip rings

		Power / Current (Load)	Signal (Data)	Pneumatics	Hydraulics	N° of channels max.	Ø Hollow shaft max. in mm [inch]	Current max. in A	Protection max.	Speed max. in RPM	Temperature range max. in °C [°F]	Page
	Modular, construction system <b>SR085</b>	•	•	•	•	20	30 [1.18]	25	IP64	800	-35 ... +85 [-31 ... +185]	20
	Modular, construction system, bearingless <b>SR085B</b>	•	•	–	–	10	34 [1.34]	16	IP40	200	0 ... +75 [+32 ... +167]	23
	Modular, contactless signal transmission <b>SRI085</b>	•	•	–	–	9	30 [1.18]	16	IP64	800	-30 ... +85 [-22 ... +185]	25
	Compact, low-maintenance <b>SR060E</b>	•	•	–	–	5	25 [0.98]	20	IP64	500	0 ... +75 [+32 ... +167]	27

### Optical fibre transmission modules (LWL)







		Interface	Transmission distance in m	Input frequency in kHz	Temperature in °C [°F]	Power / Current in VDC	Power consumption in W	Page
	Optical fibre module, incremental <b>LWL</b>	RS422 HTL	1.000	400	-10 ... +60 [-14 ... +140]	5 10 ... 30	2	32
	Optical fibre module, absolute <b>LWL.A</b>	SSI	2.000	1.000	-10 ... +70 [-14 ... +158]	5 10 ... 30	1	34







## Product overview

### Connection technology

Cable, unprepared, cut to length





	PVC cable	PUR cable	TPE cable	Cross section in mm <sup>2</sup>	Cable diameter in mm	for incremental encoders	for absolute encoders	Page
 5 core + shield	•	•	–	5 x 0.14 [AWG25] 5 x 0.75 [AWG18]	approx. 4.7 approx. 7.5	•	–	40
 8 core + shield	–	•	–	8 x 0.14 [AWG25]	approx. 5.5	–	•	40
 10 core + shield	–	•	–	4 x 2 x 0.25 [AWG23] + 2 x 1 [AWG17]	approx. 7.9	•	•	40
 12 core + shield	•	•	•	10 x 0.14 [AWG25] + 2 x 0.5 [AWG20] 12 x 0.14 [AWG25] 6 x 2 x 0.14 [AWG25] 5 x 2 x 0.14 [AWG25] + 2 x 0.5 [AWG20] 6 x 2 x 0.14 [AWG25]	approx. 6.9 approx. 6.7 approx. 7.5 approx. 8.5 approx. 7.3	•	•	41
 18 core + shield	•	–	–	18 x 0.14 [AWG25]	approx. 7.8	–	•	41
 PROFIBUS DP DeviceNet CANopen EtherCAT / PROFINET IO / EtherNet IP	•	•	–	2 x 0.34 [AWG25] 2 x 0.52 [AWG20] + 2 x 1.04 [AWG17] 3 x 2 x 0.25 [AWG23] 2 x 2 x 0.34 [AWG22]	approx. 7.6 approx. 8.4 approx. 6.2 approx. 4.8	•	•	42

## Product overview

<b>Connection technology</b> Connectors, self-assembly		<b>N° of pins</b>	<b>Housing</b>	<b>Connection technology</b>	<b>Cable diameter Ø in mm</b>	<b>Straight connector</b>	<b>Right angle connector</b>	<b>Wall/panel lead-through</b>	<b>for fieldbus</b>	<b>Page</b>
	M12	4/5/8/12	Metal	Screw terminals	6 - 8	•	•	•	•	<b>43</b>
	M23	12/17	Metal	Solder pins	5,5 - 10,5	•	–	•	–	<b>59</b>
	MIL	7/10	Metal	Solder pins	5 - 8	•	–	–	–	<b>65</b>
	RJ45	8	Plastic	Crimp connection	4,5 - 8	•	–	–	•	<b>66</b>
	Sub-D	9	ABS metallized	Solder pins	6 - 8	–	•	–	–	<b>69</b>

## Product overview

### Connection technology Cordsets, pre-assembled

		PVC cable	PUR cable	TPE cable	Optical fibre	Straight connector	Right angle connector	for incremental encoders	for SSI / BISS encoders	for fieldbus	for analogue interfaces	Page
	with M12 connector	•	•	–	–	•	•	•	•	•	•	49
	with M23 connector	•	•	•	–	•	–	•	•	–	•	61
	Simplex patch cable optical fibre	–	–	–	•	•	–	•	•	–	–	32
	with RJ45 connector	–	•	–	•	–	–	–	•	–	–	67
	with Sub-D connector	•	•	–	–	–	•	•	•	•	–	70

## Slip rings

### General information / Mounting

#### Description

Slip rings are basically used for transmitting electrical current, signals or data, pneumatics and hydraulics from a stationary to a rotary platform.

Kübler slip rings feature a particularly rugged compact design, long maintenance cycles and a long service life.

In slip rings, the electrical transmission between the stator and rotor units takes place via sliding contacts and is extremely reliable.

The SR085 family has a modular construction and offers highest flexibility for a wide variety of applications.

#### Slip ring mounting

##### Hollow shaft mounting

- Slide the slip ring on the hollow shaft
- Tighten the setscrews and secure them with screw stop varnish
- Secure the slip ring against rotation with the torque stop

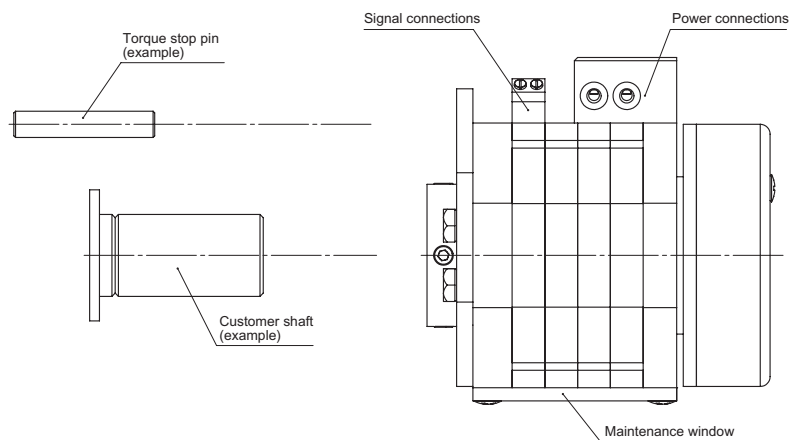

##### Flange mounting

- Connect the electrical and pneumatic transmission
- Fasten the flange with the screws and secure the screws with appropriate means, e.g. spring washers, screw stop plates
- Secure the slip ring against rotation with the torque stop

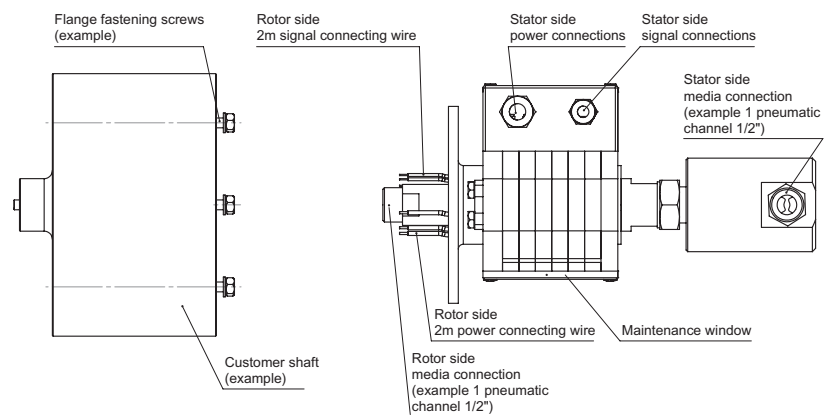

## Slip rings      Mounting

### Mounting position

The slip rings of the SR085 and SR060 series can be configured for the following electrical transmissions:

- Only signal transmission
- Only power current transmission
- Mixed transmission of signals and power

In the latter case, for a vertical installation, care must be taken so that the signal rings are always located on top. This reduces the possible risk of contaminating the signal contacts.

The slip rings of the SR085 series may be installed standing, horizontally and suspended.

A distinction is thus made among the installation positions in order to minimize the contamination of the signal channels.

The slip rings of the SR060 series are designed only for horizontal or suspended installation.

The mounting position is to be defined in the order code as follows:

SR085-XX-XX-XX-X1XXX-VXXX

in case of standing and horizontal installation (flange at the bottom)

SR085-XX-XX-XX-X2XXX-VXXX

in case of suspended and horizontal installation (flange on top)

SR085-XX-XX-XX-X0XXX-VXXX

in case of only load or only signal transmission

### Mounting position standing

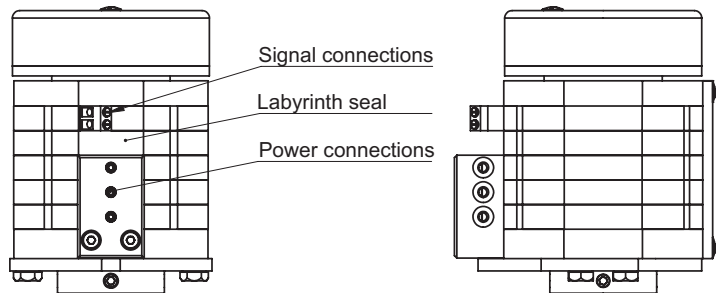

### Ex. of mounting shaft (customer side)

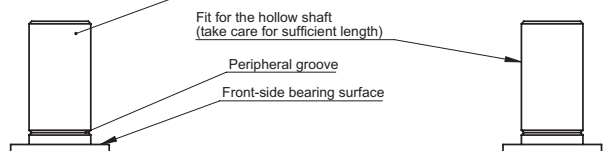

### Mounting position suspended

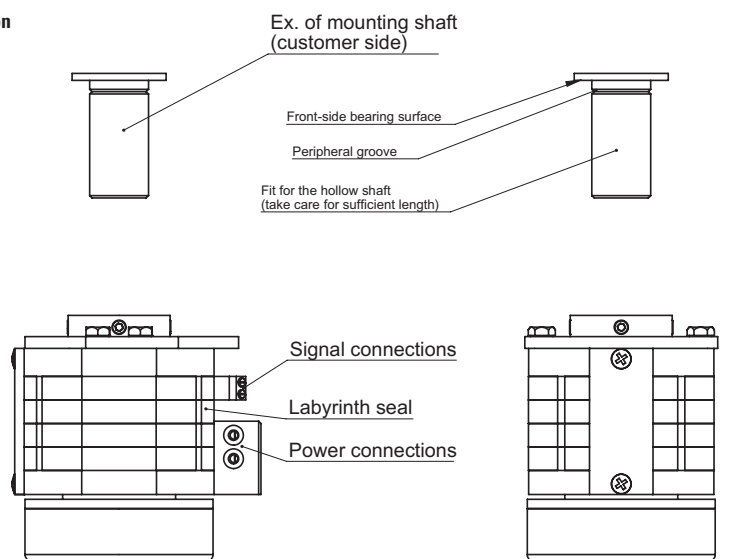

## Slip rings Contactmaterials and characteristics

### For load transmission

#### Copper alloy

**Use:** Standard contacts for power channels

**Characteristics:** Suitable for high currents, very low voltage drop, very low friction coefficient, and thus long service life



Stator ring with copper alloy contacts

#### Bronze

**Use:** Standard slip ring for power channels

**Characteristics:** Good contact properties, long service life



Bronze slip rings with insulator

### For signal / data transmission

#### Silver alloy

**Use:** Standard contact for signal/data channels

**Characteristics:** Safe transmission of data and signals, especially for very low currents and voltages, very low contact resistance, easy maintenance, no contact oil required, long service life, longer maintenance cycles



Stator ring with silver alloy contacts

#### Precious metal alloy

**Use:** As a standard slip ring for signal channels, paired with silver alloy contacts

**Characteristics:** Safe transmission of data and signals, especially for very low currents and voltages, very low contact resistance. Suitable for intermittent operation (long standstill periods)



Slip rings out of special precious metal alloy with insulator

## Slip rings

## Maintenance

### Maintenance

Regular and appropriate maintenance is determining for the safety and service life of the slip ring.

Unless otherwise specified in the technical data sheet, the following maintenance intervals apply:

- 1st interval after max. 50 million revolutions or after 1 year
- Every further maintenance interval max. 100 million revolutions or at the minimum once per year



or



or



### Maintenance plan

Depending on the rotational speed and on the operating mode, the specified maintenance intervals are reached more or less quickly. In case of continuous operation and corresponding rotational speeds, maintenance will be required, depending on the contact material of the signal/data channels, after the following number of months of operation:

**Signal/data channels, contact material silver alloy / precious metal**

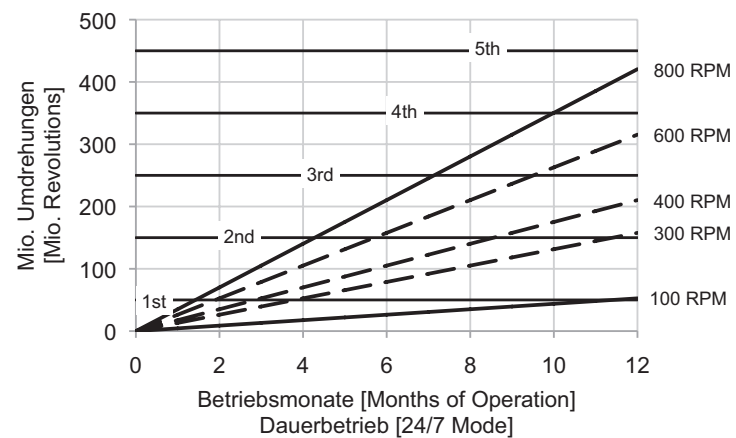

## Slip rings Maintenance

### Position of the maintenance window

Slip ring with maintenance window at the bottom  
(slip ring for power current up to 16 A)

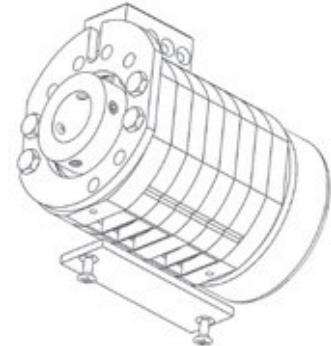

Slip ring with maintenance window on the side  
(slip ring for power current over 16 A)

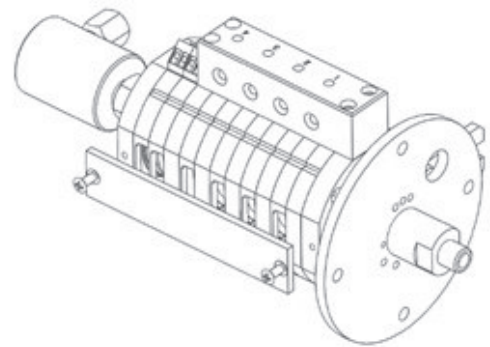

Note:

The accurate description of the maintenance work can be found in the respective maintenance instructions.

### Rotational speeds

The maximum rotational speed depends on the mounting position and on the number of channels eg. housing rings (see fig.).

For higher rotational speeds, please contact the manufacturer.

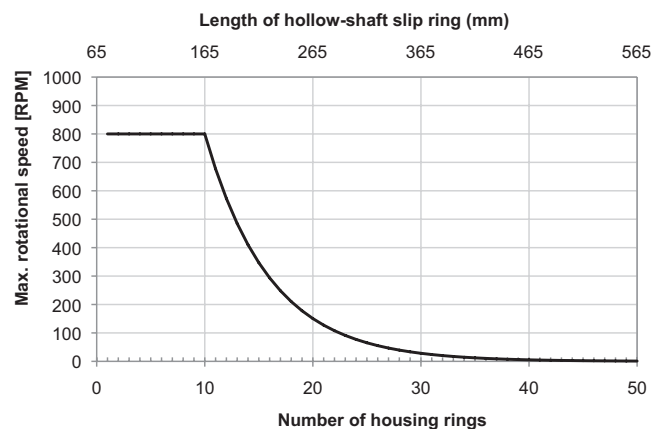

Slip rings are to be mounted by the customer so as to prevent them from oscillating and to ensure optimal rotation. The setscrews must be tightened evenly.

Unless otherwise specified, the shaft receiving the slip ring should have a h7 fit.

Whenever possible, always tighten the opposite screws consecutively and evenly. In addition, at least 1/3 of the whole slip ring length should be in contact with the shaft.

### Safety-Trans™-Design

Two-chamber system for simultaneous load and signal transmission. The power and the signal area are separated by a special labyrinth seal. This allows minimizing a possible contamination of the signal contacts.



Optical fibre signal transmission	General information	
<p><b>Description</b></p>	<p>The system is made up of an optical fibre transmitter and an optical fibre receiver.</p> <p>The optical fibre transmitter converts the electrical signals of an encoder into optical fibre signals. A simple glass fibre allows reliable transmission up to distances of 1500 m.</p> <p>The receiver module converts the optical signals back into electrical signals.</p> <p>The modules are available in various level and power supply voltage variants.</p>	<p>Main advantages of an optical fibre transmission:</p> <ul style="list-style-type: none"> <li>• Insensitivity to electromagnetic interferences and to leakage effects between lines routed parallel</li> <li>• Significantly higher transmission speeds</li> <li>• The optical fibre cable can be routed through explosive atmospheres</li> <li>• Cost and weight savings thanks to reduced cabling work, especially for important cable lengths</li> </ul>
<p><b>Mounting of optical fibre modules</b></p>	<p>The optical fibre modules can be mounted directly on a TS35 DIN rail (top-hat rail) according to EN 50022.</p> <p>The installation width for every module is only 22.5 mm.</p>	
<p><b>Laying and connection of glass fibre cables</b></p>	<p>Laying the cable is generally easy.</p> <p>Care must nevertheless be taken to make sure that the bending radius does not become smaller than 30 mm for static laying and 60 mm for dynamic laying.</p> <p>When connecting the cable, make sure that the bayonet catch is locked and remove the dust protection caps only just before connecting the cable.</p>	
<p><b>Glass fibre cables</b></p>	<p>The modules can be connected together using 50/125 µm or 62.5/125 µm multimode glass fibre cables with ST/PC type connectors with bayonet catch. Single-mode Simplex patch cables are not suitable.</p> <p>Kübler offers finished confectioned patch cables adapted to the optical fibre modules as accessories.</p> <p>They ensure the full functionality and high signal quality of our sensors.</p>	

## Connection technology

## Introduction / Cables and connectors

### Introduction

All products of chapter Connection technology have been tested and released in relation with the corresponding compatible Kübler sensors.

They ensure the full functionality and high signal quality of our sensors - this guarantee is supported by our competent customer service.

Your advantage:

- Prevents from misconnections
  - No time-consuming search for errors
- Optimal shielding
  - Prevents from EMC problems
- Shorter mounting times
  - Time- and thus cost-savings
- No time-consuming search for the suitable connector or cable
  - Time-savings and error prevention

### Material information - Cables

#### PVC

- Suitable for average mechanical stresses in the area of packaging machines and assembly and production lines
- Good resistance against acids and alkalis and thus predestined for use in the food and beverage industry
- Limited friction resistance and partial resistance to oils and chemicals

#### PUR

- Flexible, PVC, silicone and halogen-free control cable with PUR cable jacket and polypropylene wire insulation
- The cable is oil-resistant and non-flammable according to VDE 0472, and it is resistant to chemicals, hydrolysis and microbes
- Temperature resistance from -30°C to + 90°C
- Use is possible in trailing cable carriers with a bending radius equal at least to 10 x D
- Thanks to its resistance to welding sparks, this cable is very well adapted for flexible use in the area of robotics, machine tools and metal cutting production

### Material information - Connectors

Two material groups are used for the connectors described in the catalogue:

#### Metals for contacts and housings

- Contacts:  
Metal, CuZn, gilded
- Connecting nut /compression screw:  
Metal, CuZn, nickel-plated

#### Plastics for insulator and housing

- Contact carrier:  
Plastic, TPU, black
- Body:  
Plastic, TPU, black
- Seal:  
Plastic, fluorine rubber (FKM/FPM) FPM/FKM or nitrile-butadiene rubber (NBR)

## Connection technology | Cables and connectors

Product overview  
Basics

### Coding of the M12 x 1 connectors

The connectors are coded to guarantee protection against polarity reversal. This coding is achieved by means of a peg or a notch in the contact carrier.

Kübler connectors make a distinction between A, B or D coding.

#### A-coding

Female connector with coupling nut: Coding notch  
 Male connector with external thread: Coding peg  
 Use: CANopen and 8-pin connector

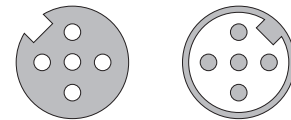

#### B-coding

Female connector with coupling nut: Coding peg  
 Male connector with external thread: Coding notch  
 Use: Profibus

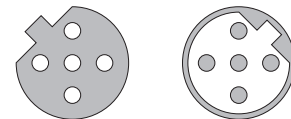

#### D-coding

Female connector with coupling nut: Coding peg and Coding notch  
 Male connector with external thread: Coding peg and Coding notch  
 Use: Profinet and EtherCAT

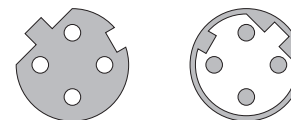

### Shielding

With round connectors, care must be taken to connect carefully the shielding braid of the cable to the shield connection of the connector.

An all-round contact (360°) is optimal. Good (in practice often sufficient) shielding values are also reached by connecting the shielding braid firmly to the electrically conductive housing. Connectors purely out of plastic, without metal sleeve, providing no contact for the shielding braid, are not sufficient.

Furthermore, a proper contact with the mating connector is also important, as well as a good contact of the mating connector with the chassis of the equipment.



"Allround" shielding with Kübler cordsets

### Counting direction cw/ccw

The counting direction of the connectors is indicated by cw for a clockwise arrangement and ccw for a counter-clockwise arrangement. The connector is always viewed from the mating side.

Top view of mating side

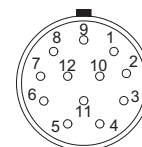

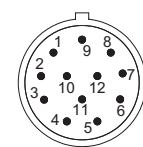

Counting direction cw (e.g. female connector)

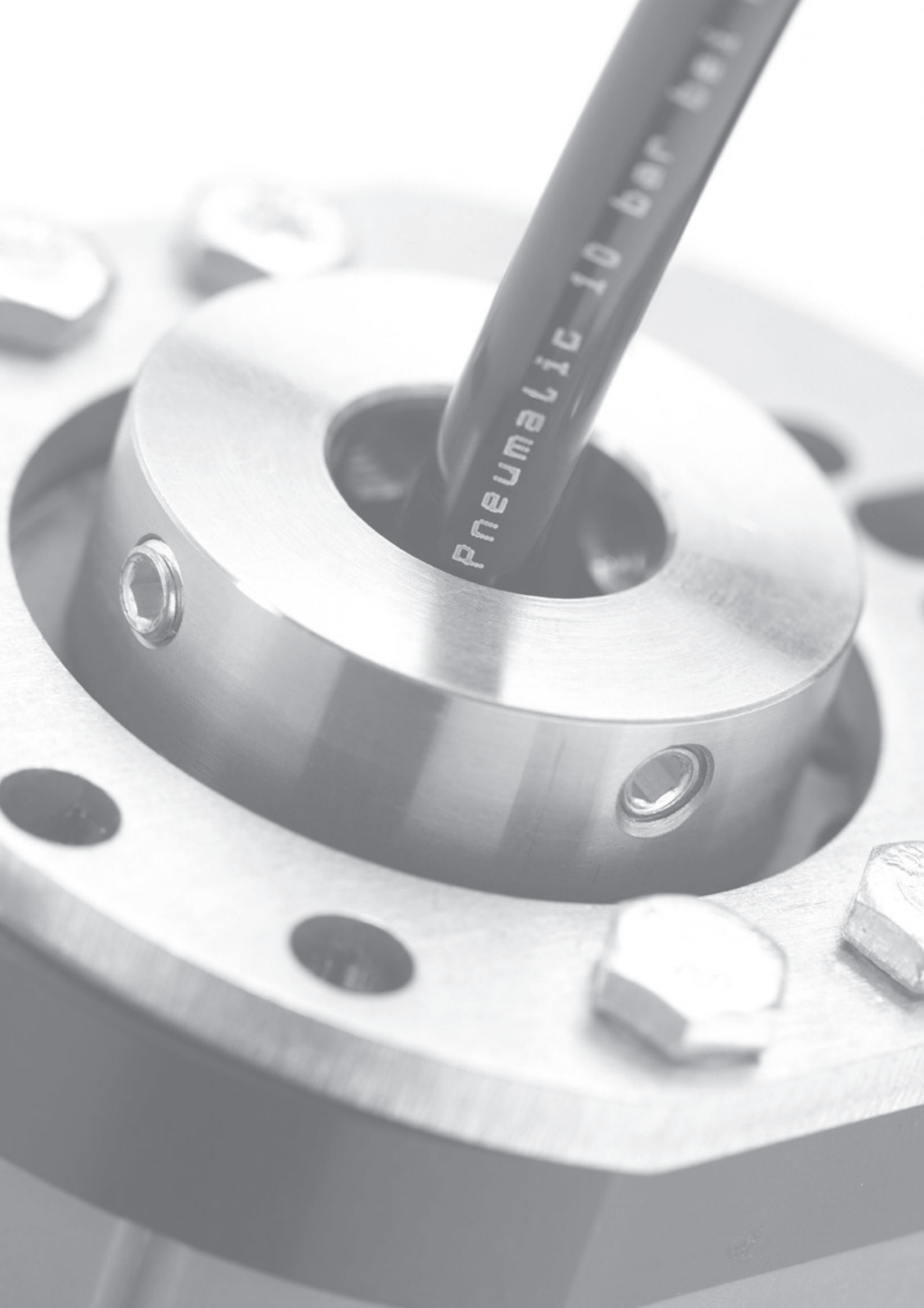

Counting direction ccw (e.g. male connector)



# Slip rings

		Type	Page	
<b>Slip rings</b>		Modular – Construction system	SR085	<b>20</b>
		Modular – Construction system, bearingless	SR085B	<b>23</b>
		Modular – Contactless signal transmission	SRI085	<b>25</b>
		Compact – Low-maintenance	SR060E	<b>27</b>

# Slip rings

<b>Modular</b>	<b>Construction system</b>	<b>SR085</b>
----------------	----------------------------	--------------



In general slip rings are used to transmit power, signals or data, pneumatic and hydraulic, from a stationary to a rotating platform.

The transmission between the stator and rotor takes place via sliding contacts and is extremely reliable.

The construction is modular and offers the greatest flexibility in a variety of applications.

## Flexible and rugged

- Modular construction system, load and signal/data channels can be combined as desired.
- Rugged GFPC housing (glass-reinforced polycarbonate), 30% glass-fibre content for industrial usage.
- Long service life and long maintenance cycles.

## Reliable with Safety-Trans™ Design

- Two-cavity system for load and signal transmission.
- Labyrinth seal.
- High vibration resistance.
- Fieldbus signals such as Profibus, CANopen etc. up to 12 Mbit/sec.

## Applications

Packaging machines, textile machines, pipeline inspection systems, video surveillance equipment (CCTV), bottling plants, rotary tables

## Standard models

Delivery time is 10 working days for a maximum of 10 pcs. per delivery. Larger quantities have a delivery time of 15 working days (or alternatively on request).



	Signal / data channels	Load channels	Contact material	Order-No.
<b>Hollow shaft 25 mm [0.98"]</b>	4 x	4 x	silver / precious metal	<b>SR085-25-04-04-11301-V100</b>
	6 x	6 x	silver / precious metal	<b>SR085-25-06-06-11301-V100</b>
<b>Hollow shaft 30 mm [1.18"]</b>	2 x	3 x	silver / precious metal	<b>SR085-30-02-03-11301-V100</b>
	6 x	6 x	silver / precious metal	<b>SR085-30-06-06-11301-V100</b>

## Order code

**SR085** - **XX** - **XX** - **XX** - **XXXXXX** - **V100**

Type      **a**      **b**      **c**      **d** **e** **f** **g** **h**      **i**

**Please note:** non-standard models will be checked for availability - an alternative model may be proposed. Minimum order quantity 5 pieces for new models. Delivery time 20 to 25 working days. For list of all available types, see [www.kuebler.com/sr-list](http://www.kuebler.com/sr-list)

### **a** Type of mounting

- 00 = flange mounting
  - 20 = hollow shaft, ø 20 mm [0.79"]
  - 24 = hollow shaft, ø 24 mm [0.94"]
  - 25 = hollow shaft, ø 25 mm [0.98"]
  - 30 = hollow shaft, ø 30 mm [1.18"]
  - IN = hollow shaft, ø 1"
- (other options on request)

### **d** Max. load current

- 0 = no load channels
- 1 = 16 A, 240 V AC/DC
- 2 = 25 A, 240 V AC/DC
- 3 = 10 A, 400 V AC/DC
- 4 = 20 A, 400 V AC/DC

### **f** Contact material for signal / data channels<sup>2)</sup>

- 0 = no signal channels
- 3 = silver / precious metal

### **h** Protection rating

- 1 = IP50
- 2 = IP64

### **b** Number of signal / data channels<sup>1)</sup>

### **c** Number of power (load) channels<sup>1)</sup>

### **e** Mounting position

- 0 = any, only with either load or signal channels
- 1 = standing and horizontal (flange down)
- 2 = hanging and horizontal (flange up)

### **g** Media lead-through

- 0 = none
- only flange mounting (00):**
- 1 = air, connection 1/4"
- 2 = air, connection 1/2"
- 3 = air, connection 3/8"
- 4 = hydraulics, connection 1/2"
- 5 = hydraulics, connection 3/8"

### **hollow shaft or shaft mounting:**

- 6 = air, rotatable connector (up to 300 rpm)

### **i** Version number (options)

- V100 = without options
- >V100 = Options on request, e.g.:
  - > 20 channels
  - other types of mounting
  - other types of connection
  - e.g. plug connectors

1) 20 combination max., for example 4 data channels and 16 load channels.  
2) Contact material gold / gold and copper / bronze on request.

# Slip rings

<b>Modular</b>	<b>Construction system</b>	<b>SR085</b>
----------------	----------------------------	--------------

Technical data (standard version)	
<b>Overall length</b>	dep. on the number of transmission paths
<b>Hollow shaft diameter</b>	up to $\varnothing$ 30 mm [1.18"]
<b>Voltage/current loading</b>	
load channels	240 V AC/DC, max. 16 A (order option 1) 240 V AC/DC, max. 25 A (order option 2) 400 V AC/DC, max. 10 A (order option 3) 400 V AC/DC, max. 20 A (order option 4)
signal / data channels	48 V AC/DC, max. 2 A
<b>Contact resistance</b>	
load channels	$\leq$ 1 Ohm (dynamic) <sup>1)</sup>
signal / data channels	$\leq$ 0.1 Ohm (silver / precious metal) <sup>2)</sup>
<b>Insulation resistance</b>	$10^3$ MOhm, at 500 V DC
<b>Dielectric strength</b>	1000 V eff. (60 sec.)
<b>Speed max. (signal / data channels)</b>	800 min <sup>-1</sup> , up to 10 channels (depends on installation position and numbers of channels)
<b>Service life (signal / data channels)</b>	typ. 500 million revolutions (at room temperature) depends on installation position
<b>Maintenance cycles</b>	first maintenance after 50 million revolutions, all further maintenance intervals after 100 million revolutions
<b>Maintenance</b>	contact oil not required
<b>Material pairing</b>	
load channels	copper / bronze
signal / data channels	silver / precious metal
<b>Operating temperature</b>	-35° ... +85°C [-31°F ... +185°F]
<b>Protection acc. to EN 60529</b>	max. IP64
<b>Transmission paths</b>	max. 20 (> 20 on request)
<b>Standards</b>	EN 61010-1 2001, VDE 0110 part 1, VDE 0295/6.92, VDE 0100 part 523

## Modular construction system

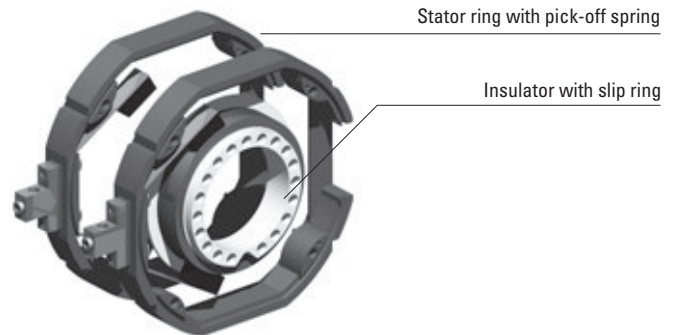

## Technology in detail

Easily accessible connections



Practical maintenance window

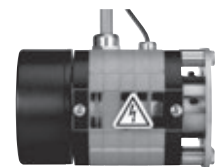

IP64 version with rotor and stator protective cover



Hollow shaft mounting with rotatable connector (air)



Version with media lead-through (air, hydraulics)



1) Voltage measurement, ambient temperature, DC series connection, ohmic load, min. 4 A test current.  
2) 2-wire resistance measurement, ambient temperature, 6.5-digit digital multimeter or similar, values without testing cable.

# Slip rings

<b>Modular</b>	<b>Construction system</b>	<b>SR085</b>
----------------	----------------------------	--------------

## Dimensions

Dimensions in mm [inch]

### Standard version

Example: Type SR085-25-02-03-11301-V100  
(2 data channels, 3 load channels)

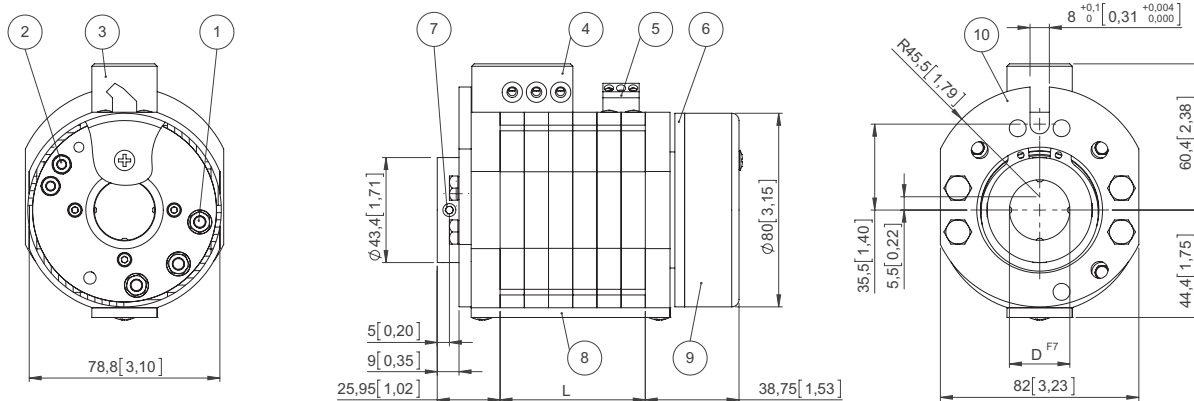

- |  |   |                                      |
|--|---|--------------------------------------|
| 1 – Screw terminal M5 for load transmission  | 4 – Wire lead-in for power possible on both sides | 8 – Maintenance window               |
| 2 – Screw terminal M4 for signal transmission  | 5 – Terminal clamp for signal transmission        | 9 – Protective cover for connections |
| 3 – Terminal clamp for power without wire protection, with shock-hazard touch protection | 6 – Rotating connection ring                      | 10 – Torque stop                     |
|  | 7 – 4 x socket set screw DIN 914 M6               |                                      |

### Air lead-through versions

Example: Type SR085-00-04-03-11322-V100

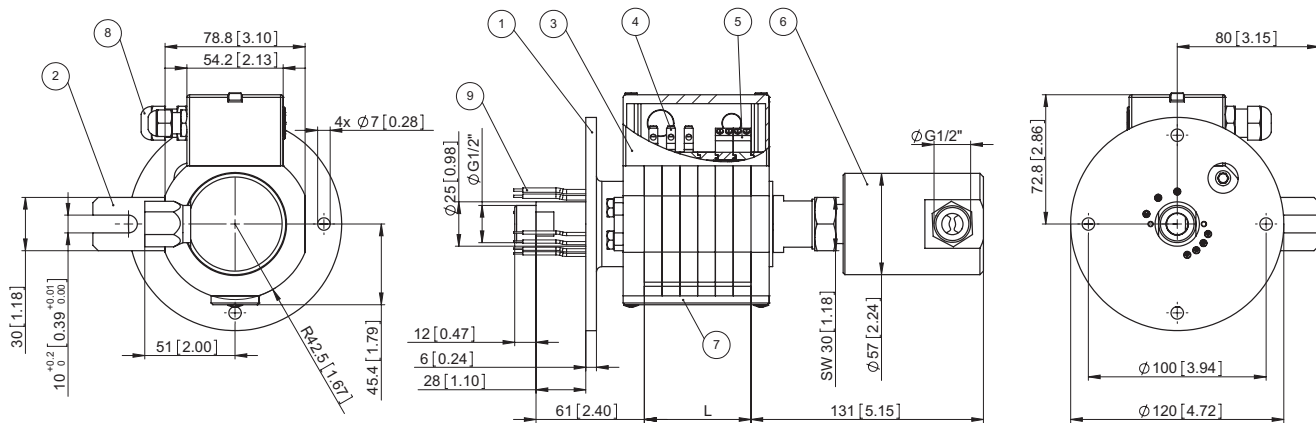

- |                             |                           |                        |
|-----------------------------|---------------------------|------------------------|
| 1 – Mounting flange         | 4 – Terminal clamp power  | 7 – Maintenance window |
| 2 – Torque stop             | 5 – Terminal clamp signal | 8 – Cable gland        |
| 3 – Stator protective cover | 6 – Media lead-through    | 9 – Connection wires   |

### Calculation of the overall length

Basic dimensions	
slip ring with hollow shaft	64.5 mm [2.54"]
slip ring with flange mounting and media lead-through 1/2" or 3/8"	185 mm [7.28"]
slip ring with flange mounting and media lead-through 1/4"	168 mm [6.61"]
Additional dimensions	
+ number of signal/data channels (silver / precious metal)	+ 10 mm [0.39"] per data channels
+ number of load channels, order options 1 and 2	+ 10 mm [0.39"] per load channel
+ number of load channels, order options 3 and 4 (10 or 20 A, 400 V)	+ 20 mm [0.79"] per load channel, if only load + 10 mm [0.39"]
+ labyrinth isolation ring for load and signal transmission	+ 10 mm [0.39"]



# Slip rings

<b>Modular</b>	<b>Construction system, bearingless</b>	<b>SR085B</b>
----------------	---	---------------

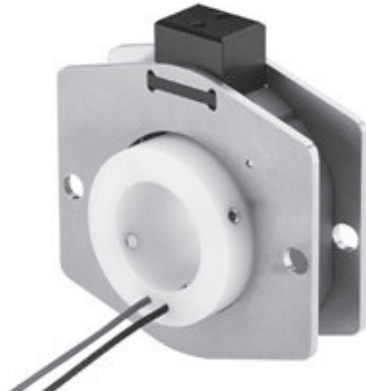

In general slip rings are used to transmit power, signals or data from a stationary to a rotating platform.

The SR085B is a cost-effective bearingless slip ring. Its flexible modular system allows a wide range of customer-specific applications.

The SR085B is ideally suited for the transmission of signals, data and/or loads.

Slip rings

<h3>Flexible and slim</h3> <ul style="list-style-type: none"> <li>• Modular construction system, can be combined as desired.</li> <li>• From 33 mm mounting depth.</li> <li>• Cost-effective bearingless construction.</li> <li>• Long service life and long maintenance cycles.</li> </ul>	<h3>Applications</h3> <p>Revolving doors, rotary tables, rotary show cases, packaging machines, other low speed applications.</p>
---	---

Order code	<b>SR085B - XX - XX - 1 0 X - V100</b>					
	Type	a	b	c	d e	f
<b>a</b> Type of mounting	20 = hollow shaft, ø 20 mm [0.79"] 24 = hollow shaft, ø 24 mm [0.94"] 25 = hollow shaft, ø 25 mm [0.98"] 30 = hollow shaft, ø 30 mm [1.18"] 34 = hollow shaft, ø 34 mm [1.34"] (other options on request)	<b>b</b> Number of channels max. 10 channels	<b>c</b> Max. load current 1 = 16 A, 240 V AC/DC	<b>d</b> Mounting position 0 = any	<b>e</b> Contact material 3 = silver / precious metal 5 = copper / bronze	<b>f</b> Version number (options) V100 = without options >V100 = options on request

Technical data (standard version)	
<b>Overall length</b>	dep. on the number of transmission paths
<b>Hollow shaft diameter</b>	up to ø 34 mm [1.34"]
<b>Voltage/current loading</b>	240 V AC/DC, max. 16 A
<b>Contact resistance</b>	load channels ≤ 1 Ohm (dynamic) <sup>1)</sup> signal / data channels ≤ 0.1 Ohm (silver / precious metal) <sup>2)</sup>
<b>Insulation resistance</b>	10 <sup>3</sup> MOhm, at 500 V DC
<b>Dielectric strength</b>	1000 V eff. (60 sec.)
<b>Speed max.</b>	200 min <sup>-1</sup>
<b>Protection acc. to EN 60529</b>	IP40
<b>Service life</b>	typ. 500 million revolutions (at room temperature) depends on installation position
<b>Maintenance cycles</b>	typ. 100 million revolutions
<b>Maintenance</b>	contact oil not required
<b>Operating temperature</b>	0°C ... +75°C [+32°F ... +167°F]

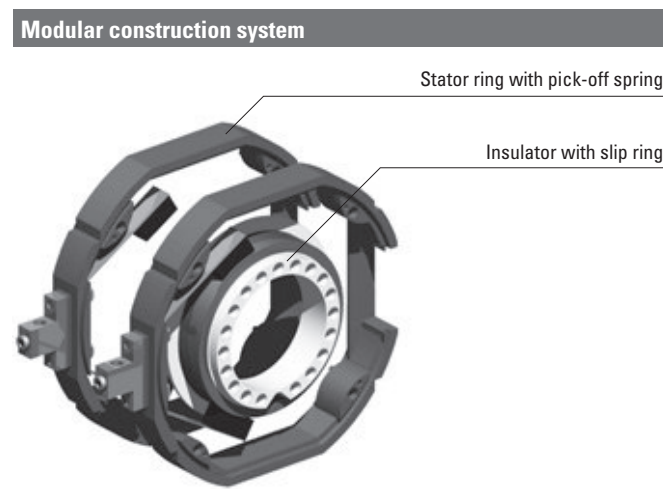

1) Voltage measurement, ambient temperature, DC series connection, ohmic load, min. 4 A test current.  
2) 2-wire resistance measurement, ambient temperature, 6.5-digit digital multimeter or similar, values without testing cable.

# Slip rings

**Modular**      **Construction system, bearingless**      **SR085B**

## Dimensions

Dimensions in mm [inch]

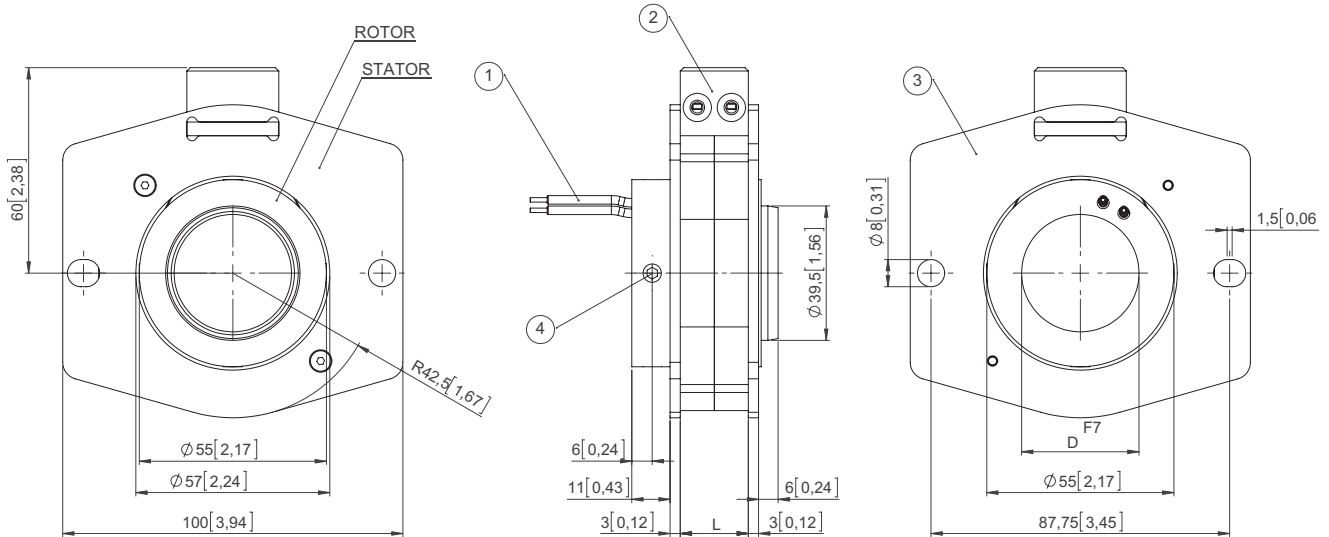

Permitted misalignment rotor/stator  
axial = max 0.5 mm  
radial = max 0.5 mm

- 1 – Connection wires
- 2 – Terminal clamp for power without wire protection, with shock-hazard touch protection
- 3 – Stator cover, mounting plate
- 4 – 4 x socket set screw DIN 914 M6

Calculation of total length L:

Basic dimension: 23 mm [0.91"]

Additional dimension: +10 mm [0.39"] per channel

# Slip rings

<b>Modular</b>	<b>Contactless signal transmission</b>	<b>SRI085</b>
----------------	--	---------------



In general slip rings are used to transmit electrical power, signals or data, pneumatic and hydraulic, from a stationary to a rotating platform.

In the SRI085, signal transmission occurs by means of a contactless inductive coupling. This ensures the data channels without maintenance requirements.

The construction is modular and offers the greatest flexibility in a variety of applications.

Slip rings

<p><b>Flexible and rugged</b></p> <ul style="list-style-type: none"> <li>• Modular construction system, load and signal/data channels can be combined as desired</li> <li>• Rugged GFPC housing (glass-reinforced polycarbonate) for industrial usage</li> </ul>	<p><b>Maintenance-free</b></p> <ul style="list-style-type: none"> <li>• Signal / data channels maintenance-free by means of inductive coupling</li> <li>• Long service life</li> </ul> <p><b>Applications</b></p> <p>Packaging machines, rotary tables and textile machines</p>
--	---

Standard versions				Order No.
	Signal / data channels	Load channels	max. load current	
<b>Hollow shaft 25 mm [0.98"]</b>	3 x	4 x	16 A, 240 V AC/DC	<b>SRI085-25-03-04-1101-V100</b>
Other options on request:				
• Hollow shaft up to $\varnothing$ 30 mm [1.18"]				
• Number of data channels – max. 3 PT100 pairs				
• Number of load channels – max. 6 channels				
• Protection max. IP64				

Connection technology		Order No.
<b>Connector, self-assembly (straight)</b>	M12 female connector with coupling nut	<b>05.CMB 8181-0</b>
<b>Cordset, pre-assembled</b>	M12 female connector with coupling nut, 2 m [6.56'] PUR cable	<b>05.00.6051.8211.002M</b>

Additional connectors can be found in the connection technology section or in the connection technology area of our website at: [www.kuebler.com/connection\\_technology](http://www.kuebler.com/connection_technology).

## Easily accessible connections



# Slip rings

<b>Modular</b>	<b>Contactless signal transmission</b>	<b>SRI085</b>
----------------	--	---------------

## Technical data

Load transmission	
<b>Current carrying capacity</b> voltage / current	max. 240 V / 16 A max. 240 V / 25 A
<b>Contact resistance</b>	< 1 Ohm
<b>Insulation resistance</b>	< 10 <sup>9</sup> MOhm
<b>Dielectric strength</b>	1000 V eff.

Data transmission	
<b>Data signal</b>	PT100
<b>Measuring range</b>	0°C ... +300°C [+32°F ... + 572°F] (4 ... 20 mA)
<b>Power supply</b>	24 V DC, ±10%
<b>Power consumption</b>	max. 250 mA at 24 V DC
<b>Max. load of the current source</b>	400 Ohm
<b>Type of connection</b>	Flange connector M12, A coded (terminal assignment see connection table)

Mechanical characteristics		
	only data transmission SRI085-XX-0X-00-010X-V100	mixed data and load transmission SRI085-XX-XX-XX-X101-V100
<b>Speed</b>	max. 800 min <sup>-1</sup>	max. 800 min <sup>-1</sup>
<b>Service life</b>	–	typ. 500 million revolutions
<b>Maintenance cycles</b>	maintenance-free	100 million revolutions
<b>Operating temperature</b>	-30°C ... +85°C [-22°F ... +185°F]	-30°C ... +85°C [-22°F ... +185°F]
<b>Protection to EN 60529</b>	max. IP64	max. IP50
<b>Contact material load channel</b>	–	copper/bronze

### Terminal assignment

Interface	Flange connector M12, 8 pin								
1	Signal:	channel 2, PT100	channel 3, PT100	channel 3, 0 V	0 V	+24 V	channel 1, PT100	channel 1, 0 V	channel 2, 0 V
	Pin:	1	2	3	4	5	6	7	8

### Top view of mating side, male contact base



Flange connector M12, 8 pin

### Dimensions

Dimensions in mm [inch]

Example: SRI085-25-03-03-1101-V100

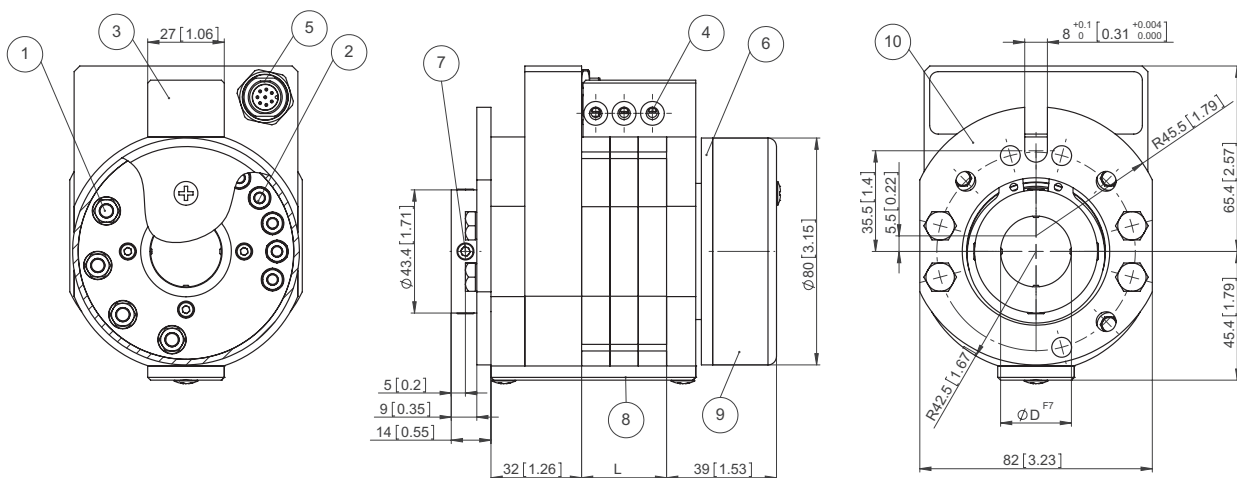

- |  |   |  |
|--|---|--|
| <ul style="list-style-type: none"> <li>1 – Screw terminal M5 for load transmission</li> <li>2 – Screw terminal M4 for signal transmission</li> <li>3 – Terminal clamp for power without wire protection, with shock-hazard touch protection</li> </ul> | <ul style="list-style-type: none"> <li>4 – Wire lead-in for power possible on both sides</li> <li>5 – Flange connector M12, A coded</li> <li>6 – Rotating connection ring</li> <li>7 – 4 x socket set screw DIN 914 M6</li> </ul> | <ul style="list-style-type: none"> <li>8 – Maintenance window</li> <li>9 – Protective cover for connections</li> <li>10 – Torque stop</li> </ul> |
|--|---|--|

# Slip rings

<b>Compact</b>	<b>Low-maintenance</b>	<b>SR060E</b>
----------------	------------------------	---------------



**RU** pending

In general slip rings are used to transmit power, signals or data from a stationary to a rotating platform.

The SR060E is a compact, economical slip ring for up to 3 power and 2 signal transmissions.

New innovative contact materials ensure long service life and extremely low-maintenance operation. The round shape with smooth surfaces and high protection level allows easy cleaning.

Slip rings

<h3>Compact</h3> <ul style="list-style-type: none"> <li>• Dimensions 60 x 98 mm.</li> <li>• Can be used as a pair starting from just 60 mm shaft distance of the sealing rollers.</li> <li>• Various component configurations for the transmission paths, max. 3 x load and 2 x signal transmission.</li> <li>• Easily accessible connections.</li> <li>• Load current up to 20 A.</li> </ul>	<h3>Low-maintenance</h3> <ul style="list-style-type: none"> <li>• Maintenance cycles only every 100 million revolutions.</li> <li>• No contact oil required.</li> <li>• Easy cleaning – high protection level IP64.</li> </ul>
<h3>Applications for slip rings</h3> <p>Flowpack and blister packaging machines, robots and handling equipment, rotary tables</p>	

<b>Order code</b> for standard versions	<b>SR060E</b> - <b>XX</b> - <b>X</b> - <b>X</b> - <b>XX</b> <b>2</b> - <b>V100</b>
Type	a b c d e f g
<b>a</b> Hollow shaft 20 = ø 20 mm [0.79"] 22 = ø 22 mm [0.87"] 24 = ø 24 mm [0.94"] 25 = ø 25 mm [0.98"] (other diameters on request)	<b>b</b> Number of signal / data channels 0 or 2
<b>c</b> Number of load channels 0, 2 or 3	<b>d</b> Max. load current 0 = no load channels 1 = 16 A, 240 V AC/DC 2 = 20 A, 240 V AC/DC
<b>e</b> Contact material signal / data channels 0 = no signal / data channels 3 = silver / precious metal	<b>f</b> Protection 2 = IP64
<b>g</b> Version number (options) V100 = without option > V100 = option on request	

Technical data	
<b>Hollow shaft diameter</b>	up to max. ø 25 mm [0.98"]
<b>Voltage/current loading</b>	
load channels	240 V AC/DC, max. 16 A
signal / data channels	240 V AC/DC, max. 20 A (order option 2)
<b>Contact resistance</b>	
load channels	≤ 1 Ohm (dynamic) <sup>1)</sup>
signal / data channels	≤ 0.1 Ohm (silver / precious metal) <sup>2)</sup>
<b>Insulation resistance</b>	10 <sup>3</sup> MOhm (at 500 V DC)
<b>Dielectric strength</b>	1000 V eff. (60 sec.)
<b>Speed max.</b>	500 min <sup>-1</sup>

<b>Service life</b>	typ. 500 million revolutions (at room temperature) depends on installation position
<b>Maintenance cycles</b>	first maintenance after 50 million revolutions, all further maintenance intervals after 100 million revolutions
<b>Maintenance</b>	contact oil not required
<b>Material pairing</b>	
load channels	copper / bronze
signal / data channels	silver / precious metal
<b>Operating temperature</b>	0°C ... +75°C [+32°F ... +167°F]
<b>Protection acc. to EN 60529</b>	IP64
<b>Standards</b>	VDE 0110 and VDE 0295/6.92

1) Voltage measurement, ambient temperature, DC series connection, ohmic load, min. 4 A test current.  
2) 2-wire resistance measurement, ambient temperature, 6.5-digit digital multimeter or similar, values without testing cable.

# Slip rings

**Compact**      **Low-maintenance**      **SR060E**

## Dimensions

Dimensions in mm [inch]

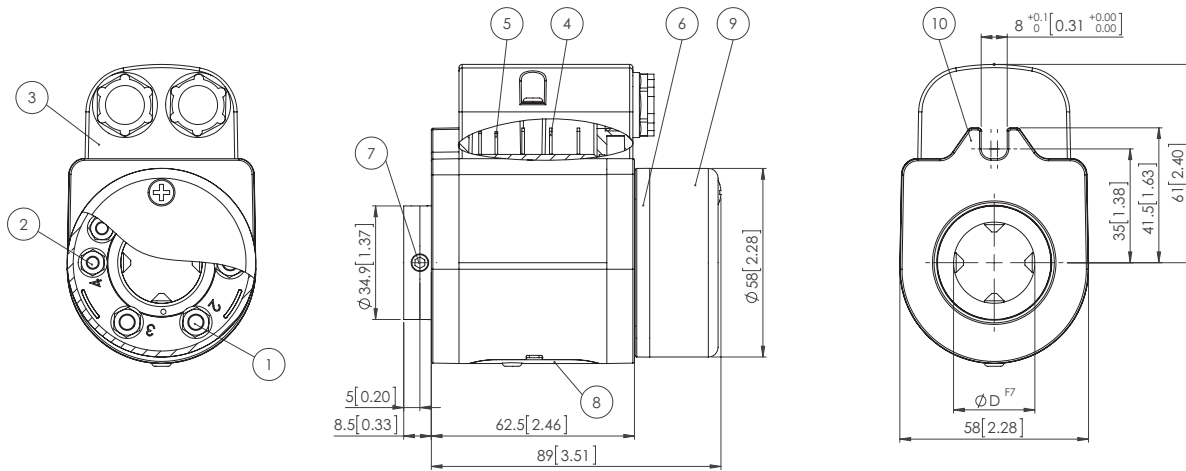

- |   |   |                                      |
|---|---|--------------------------------------|
| 1 – Screw terminal M5 for load transmission                                       | 4 – Flat pin connection for load transmission   | 8 – Maintenance window               |
| 2 – Screw terminal M4 for signal transmission                                     | 5 – Flat pin connection for signal transmission | 9 – Protective cover for connections |
| 3 – Protective cover for the stator connections with screwed assembly (only IP64) | 6 – Rotating connection ring                    | 10 – Torque stop                     |
|   | 7 – 4 x socket set screw DIN 914 M6             |                                      |

## Slip rings

---



Power/Sync

Local Error

Remote Err



## Optical fibre transmission modules

			Page
<b>Optical fibre transmission modules</b>	RS422/HTL (incremental)	transmitter and receiver	<b>32</b>
	SSI (absolute)	transmitter and receiver	<b>34</b>

# Optical fibre transmission modules

**Optical fibre signal transmission**    **Transmitter and receiver**    **RS422/HTL**

**eco plus**  
 Cost advantage compared to conventional wiring over 150 m length\*



The solution where signal transmission is difficult.

The system is made up of an optical fibre transmitter and an optical fibre receiver. The optical fibre transmitter converts the electrical signals of a normal incremental encoder into a light signal for transmission by means of an optical fibre.

The receiving module converts the optical signal back into electrical signals. Up to 4 channels with inverted signals may be transmitted safely.

### Innovative

- Signal transmission via just a single glass fibre.
- Safe signal transmission up to 1000 m.
- Input frequency up to 400 kHz.
- Input level 10 ... 30 V or RS422.
- Inverted input signals.
- Resists extremely strong electro-magnetical fields.

### Compact



- Can be installed even where space is tight.
- Minimal installation depth.
- Connections plug-in HD-Sub D15 or terminal clamp.

### Application areas

- Process control technology and automation technology.
- Applications sensitive to interference.
- High voltage plants.
- Plants with long transmission distances.
- Potential separation.
- Explosive areas.

**Order code**  
**Optical fibre transmitter / receiver**    **6.LWLX.XX**

<p><b>a</b></p> <p>S = Optical fibre transmitter              E = Optical fibre receiver</p>	<p><b>b</b> <i>Input or output circuit / Power supply</i></p> <p>1 = RS422 / 10 ... 30 V DC              2 = HTL, without inverted signals / 10 ... 30 V DC (only for optical fibre transmitter)              4 = RS422 / 5 V DC              5 = HTL / 10 ... 30 V DC, input</p>	<p><b>c</b> <i>Type of connection</i></p> <p>0 = Terminal clamp              1 = Plug-in connector HD-Sub D15</p>	<p><i>Scope of delivery:</i></p> <ul style="list-style-type: none"> <li>- Optical fibre module</li> <li>- Multilingual operating manual</li> </ul> <p>Optical fibre transmitter versions can be combined with any version of the optical fibre receivers.</p>
--	---	---	---

Accessories		Order no.
<p><b>Simplex Patch cable</b>  <b>ST-ST - Multimode</b></p> 	<p>Connector:                  2 x ST/PC, optical fibre:                  1 x 50/125</p>	<p><b>05.B09-B09-821-XXXX</b></p> <p>XXXX = Length in m                  Standard lengths: 2 m, 5 m, 8 m, 10 m, 15 m, 20 m, ... (in 5 m steps)</p>
<p><b>ST Multimode coupling</b></p> 	<p>Barrel: ceramic, slotted</p>	<p><b>05.LWLK.001</b></p>

\* Comparison of costs:  
 Costs per meter standard copper cable compared to costs per meter optical fibre signal cable + costs of transmitter + costs of receiver.

# Optical fibre transmission modules

## Optical fibre signal transmission Transmitter and receiver RS422/HTL

### Technical data

General technical data	
Power supply	10 ... 30 DC V eg. 5 V DC ±5%
Power consumption per module	< 2 W
Operating voltage reverse connection protection	available
Encoder inputs optical fibre transmitter channels	A, $\bar{A}$ , B, $\bar{B}$ , 0, $\bar{0}$
Max. input frequency optical fibre transmitter and output frequency optical fibre receiver	400 kHz
Input level optical fibre transmitter	10 ... 30 V or RS 422
Optical wavelength	820 nm
Optical transmission rate	120 Mbit/s
Optical fibre synchronisation display	LED on the receiver
Optical fibre connection	ST connector, $\varnothing$ 9 mm [0.35] on the bottom side of the housing
Glass fibre	multimode fibre, 50/125 $\mu$ m, 62.5/125 $\mu$ m

Input signals sampling rate	10 MSamples/s	
Optical fibre transmission distance	max. 1000 m [3280.8']	
Dimensions (W x L x H)	Terminal clamp	22.5 x 110.8 x 88.4 mm [0.89 x 4.36 x 3.48"]
	Plug-in connector	19.0 x 110.8 x 88.4 mm [0.75 x 4.36 x 3.48"]
Protection acc. to EN 60529	IP40, terminals IP20	
Terminals	protected against contact	
	max. conductor diameter	2.5 mm <sup>2</sup> [AWG 23]
Temperature range	-10°C ... +60°C [+14°F ... +140°F]	
Weight	approx. 95 g [3.35 oz]	

EMC		
Standards	Emitted interference	EN 55011 class B1
	Immunity to interference	EN 61000-6-2

Optical fibre transmission modules

### Terminal assignment

Type of connection	Terminal clamp, optical fibre transmitter and optical fibre receiver											
0	Signal	$\bar{A}$	$\bar{B}$	$\bar{0}$ ( $\bar{C}$ )	A	B	0 (C)	$\bar{D}$	D	+V	0 V linked internally	Shield
	Terminal	1	2	3	4	5	6	7	10	8	9, 11, 12	–

Type of connection	HD-Sub D15, optical fibre transmitter											Terminal		
1	Signal	$\bar{A}$	$\bar{B}$	$\bar{0}$ ( $\bar{C}$ )	A	B	0 (C)	$\bar{D}$	D	+V <sub>out</sub> to encoder	0 V linked internally	Shield	0 V linked internally	+V <sub>out</sub> to encoder, linked internally
	Terminal	8	6	3	9	7	4	1	2	15	11, 12	13	1	2

Type of connection	HD-Sub D15, optical fibre receiver											Terminal		
1	Signal	$\bar{A}$	$\bar{B}$	$\bar{0}$ ( $\bar{C}$ )	A	B	0 (C)	$\bar{D}$	D	+V <sub>in</sub> power supply	0 V linked internally	Shield	0 V linked internally	+V <sub>in</sub> power supply, linked internally
	Terminal	8	6	3	9	7	4	1	2	15	11, 12	13	1	2

### Dimensions

Dimensions in mm [inch]

#### Terminal clamp

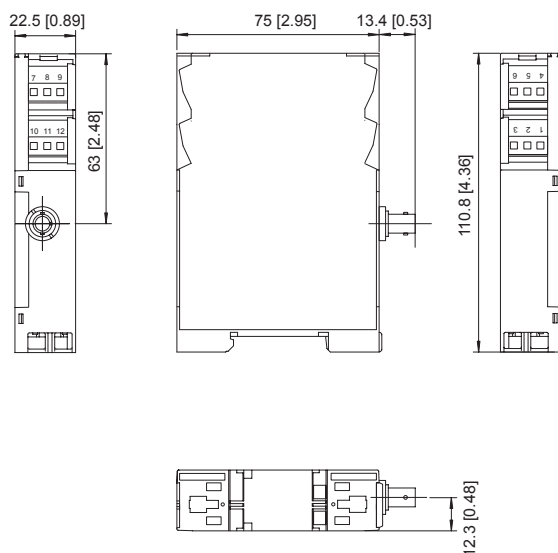

#### Plug-in connector, HD-Sub D15

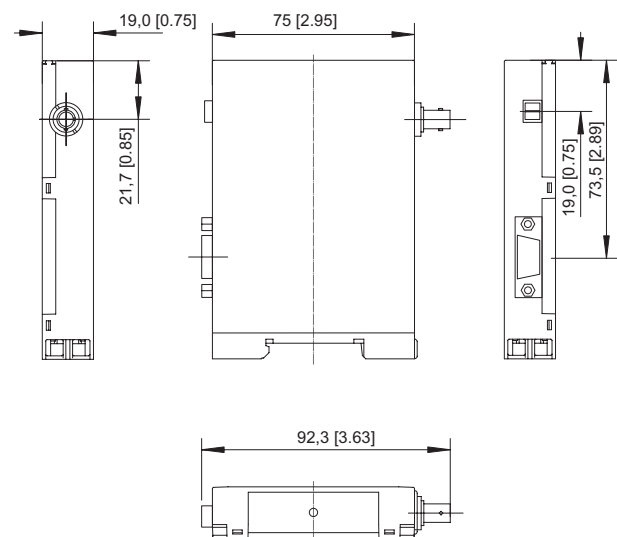

# Optical fibre transmission modules

<b>Optical fibre signal transmission</b>	<b>Transmitter and receiver</b>	<b>SSI</b>
--	---------------------------------	------------

**eco plus**  
 Cost advantage compared to conventional wiring over 150 m length\*



### Optical fibre transmission system for SSI absolute encoders

The system is made up of an optical fibre transmitter and an optical fibre receiver.

The optical fibre transmitter converts the electrical signals of a normal absolute encoder with Synchronous Serial Interface (SSI) into a light signal for transmission by means of an optical fibre. The receiving module converts the optical signal back into electrical signals.

Absolute signals can be transmitted safely through one glass fibre over distances of up to 2000 m. A rotary switch on the front side of the module allows adjusting the SSI clock between 1 and 99 bits.

### Reliable transmission

- Safe signal transmission up to 2000 m.
- Resists extremely strong electro-magnetic fields.

### Easy installation

- Signal transmission via a single glass fibre.
- Clock of 1 ... 99 bit can be set via rotary switch.
- LED for monitoring of power supply and clock.
- DIN-rail mounting – requires min. installation space – only 19 mm wide.

### Application areas

- Process control technology and automation technology.
- Crane systems.
- High voltage plants.
- Heavy industry.
- Wind power plants.
- Drive technology.
- Rolling mills.

### Order code

Optical fibre transmitter / receiver

6.LWLA . XXX  
 a b c

- |                               |                       |
|-------------------------------|-----------------------|
| <b>a</b>                      | <b>b</b> Power supply |
| S = Optical fibre transmitter | 1 = 10 ... 30 V DC    |
| E = Optical fibre receiver    | 4 = 5 V DC            |

- |                              |
|------------------------------|
| <b>c</b> Type of connection  |
| 0 = Terminal clamp           |
| 1 = Plug-in connector Sub-D9 |

*Scope of delivery:*  
 - Optical fibre transmission module  
 - Operating manual, dual language, German and English

Accessories	Order no.
<p><b>Simplex Patch cable</b>  <b>ST-ST - Multimode</b></p>	<p>Connector:            2 x ST/PC, Optical fibre:            1 x 50/125</p> <p style="text-align: right;"><b>05.B09-B09-821-XXXX</b></p> <p style="text-align: right; font-size: small;">XXXX = Length in m            Standard lengths: 2 m, 5 m,            8 m, 10 m, 15 m, 20 m, ...            (in 5 m steps)</p>
<p><b>ST Multimode coupling</b></p>	<p>Barrel: ceramic, slotted</p> <p style="text-align: right;"><b>05.LWLK.001</b></p>

\* Comparison of costs:  
 Costs per meter standard copper cable compared to costs per meter optical fibre signal cable + costs of transmitter + costs of receiver

# Optical fibre transmission modules

## Optical fibre signal transmission Transmitter and receiver SSI

### Technical data

General technical data	
Power supply	10 ... 30 DC V eg. 5 V DC ±5 %
Power consumption per module	< 1 W
Operating voltage reverse connection protection	available
Electrical inputs / outputs (Optical fibre transmitter / receiver)	Clock C+ and C-, RS422 Data D+ and D-, RS422 NPN error input on transmitter Open-Drain outout on receiver
SSI clock rate	max. 1 MHz
Optical wavelength	820 nm (infrared)
Optical fibre connection	ST connector, on the bottom side of the housing
Glass fibre	multimode fibre, 50/125 µm, 62.5/125 µm
Optical fibre transmission distance	max. 2000 m [6561']

Dimensions (W x L x H)	19.0 x 110.8 x 92.3 mm [0.75 x 4.36 x 3.63"]
Protection acc. to EN 60529	IP40, terminals IP20
Connection	terminal clamps 11-pin plug-in screw terminal, RM 3.5 Sub-D9 9-pin Sub-D female contacts (for signals) power supply 2-pin plug-in screw terminal
Temperature range	-10°C ... +70°C [+14°F ... +158°F]
Weight	appr. 70 g [2.47 oz]

EMC		
Standards	Emitted interference	EN 55011 class B1
	Immunity to interference	EN 61000-6-2

### Terminal assignment

#### Optical fibre transmitter

Type of connection	Terminal clamp											
0	Signal:	0 V	+V	C+	C-	D+	D-	input/error	-	-	-	±
	Pin female contact:	1	2	3	4	5	6	7	8	9	10	11

Type of connection	Plug-in connector, Sub-D9										
1	Signal:	0 V	+V	input/error	D-	D+	C-	C+	-	±	
	Pin female contact:	1	2	3	4	5	6	7	8	9	

#### Optical fibre receiver

Type of connection	Terminal clamp											
0	Signal:	0 V	+V	C+	C-	D+	D-	output/error	-	-	-	±
	Pin female contact:	1	2	3	4	5	6	7	8	9	10	11

Type of connection	Plug-in connector, Sub-D9										
1	Signal:	0 V	+V	output/error	D-	D+	C-	C+	-	±	
	Pin female contact:	1	2	3	4	5	6	7	8	9	

#### Power supply

Screw terminal, 2 pin			
Signal:	0 V	+V	
Pin female contact:	1	2	

Contacts 1/2 of the 2-pin plug-in screw terminal are connected to contacts 1/2 of the 11-pin plug-in screw terminal or with contacts 1/2 of the Sub-D connector.

- +V: Power supply +V DC
- 0 V: Power supply ground GND (0 V)
- C+, C-: Clock signal
- D+, D-: Data signal
- ±: Shield

# Optical fibre transmission modules

**Optical fibre signal transmission**    **Transmitter and receiver**    **SSI**

## Dimensions

Dimensions in mm [inch]

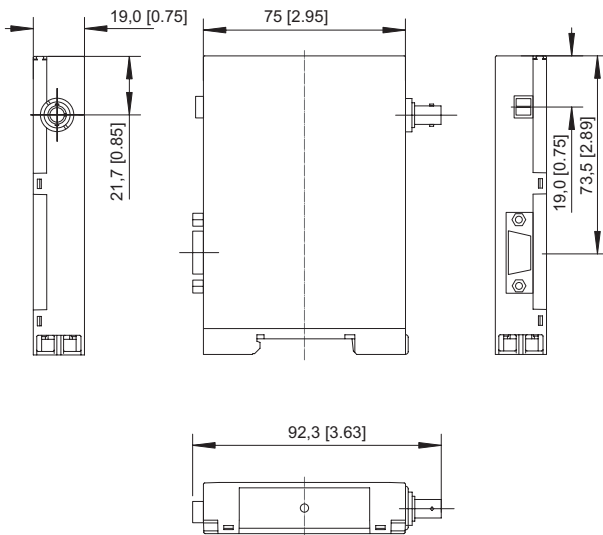

## Optical fibre transmission modules

---

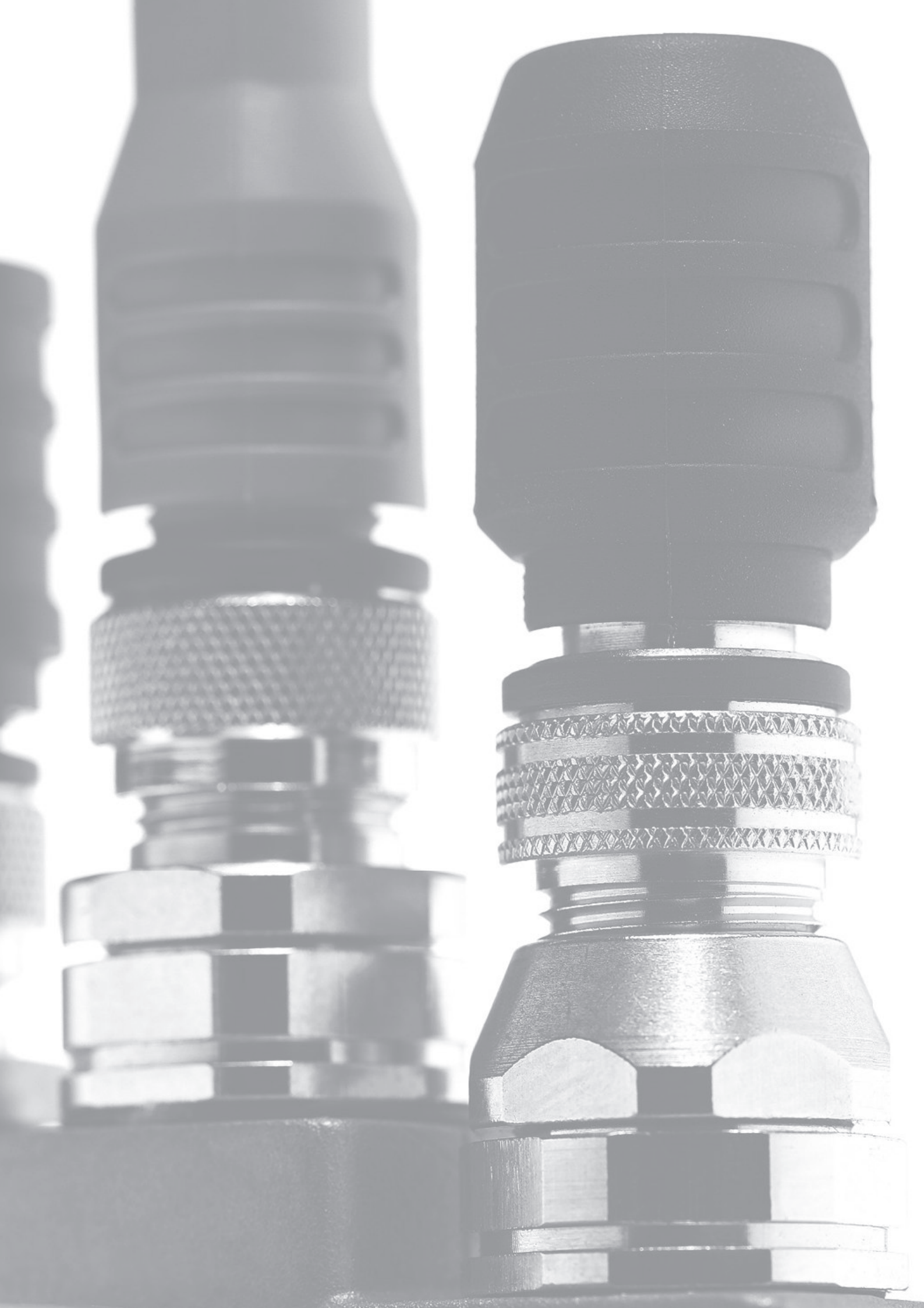



## Connection technology

		Page
<b>Cable</b>	Unprepared, cut to length	<b>40</b>
<b>M12 connection technology</b>	Connectors, self-assembly	<b>43</b>
	Cordsets, pre-assembled	<b>49</b>
<b>M23 connection technology</b>	Connectors, self-assembly	<b>59</b>
	Cordsets, pre-assembled	<b>61</b>
<b>MIL connection technology</b>	Connectors, self-assembly	<b>65</b>
<b>RJ45 connection technology</b>	Connectors, self-assembly	<b>66</b>
	Cordsets, pre-assembled	<b>67</b>
<b>Sub-D connection technology</b>	Connectors, self-assembly	<b>69</b>
	Cordsets, pre-assembled	<b>70</b>

### The idea behind our Connection Technology System



### Connection Technology from Kübler = System Safety!















All the products in the Connection Technology section have been tested and approved with the relevant compatible Kübler sensors.

They ensure the full functionality and high signal quality of our sensors.

#### Your benefit:

















- Elimination of connection errors
  - no laborious fault finding
- Optimal shielding
  - avoids EMC problems
- Shorter installation times
  - saves time, cuts costs
- No time-consuming search for the right connector or cable
  - saves time, eliminates errors

# Connection technology

Cable		Unprepared, cut to length			Order no.
<b>5 core + shield</b>					
<b>PVC electronic cable LiVCY</b>  	<b>Cross section</b>	5 x 0.14 mm <sup>2</sup> [AWG25]	suitable for:	<b>8.0000.6300.XXXX</b> <sup>1)</sup>	
	<b>Permanent working temperature range</b>	flexible installation -5°C ... +70°C [+23°F ... +158°F] secure installation -30°C ... +70°C [-22°F ... +158°F]	incremental encoders without inversions		
	<b>Bending radius</b>	flexible installation min. 70 mm [2.76"] secure installation min. 45 mm [1.77"]			
	<b>Cable diameter</b>	approx. 4.7 mm ±0.2 mm			
<b>8 core + shield</b>					
<b>TPE electronic trailing cable halogen-free, silicon-free</b>  	<b>Cross section</b>	5 x 0.75 mm <sup>2</sup> [AWG18]	suitable for:	<b>8.0000.6600.XXXX</b> <sup>1)</sup>	
	<b>Permanent working temperature range</b>	flexible installation -35°C ... +100°C [-31°F ... +212°F] secure installation -40°C ... +100°C [-40°F ... +212°F]	H100 with speed switch, robust incremental encoders without inversions		
	<b>Bending radius</b>	flexible installation min. 40 mm [1.57"] secure installation min. 25 mm [0.98"]			
	<b>Cable diameter</b>	approx. 7.5 mm ±0.3 mm			
<b>8 core + shield</b>					
<b>PUR trailing cable halogen-free</b>    	<b>Cross section</b>	8 x 0.14 mm <sup>2</sup> [AWG25]	suitable for:	<b>8.0000.6P00.XXXX</b> <sup>1)</sup>	
	<b>Permanent working temperature range</b>	flexible installation -20°C ... +90°C [-4°F ... +194°F] secure installation -40°C ... +90°C [-40°F ... +194°F]	Limes, 365X, 368X SSI and analogue Safety-M		
	<b>Bending radius</b>	flexible installation min. 65 mm [2.56"] secure installation min. 45 mm [1.77"]			
	<b>Cable diameter</b>	approx. 5.5 mm ±0.2 mm			
<b>PUR trailing cable halogen-free</b>    	<b>Cross section</b>	3 x 2 x 0.14 mm <sup>2</sup> [AWG25] + 2 x 0.5 mm <sup>2</sup> [AWG20]	suitable for:	<b>8.0000.6F00.XXXX</b> <sup>1)</sup>	
	<b>Permanent working temperature range</b>	flexible installation -40°C ... +90°C [-40°F ... +194°F] secure installation -50°C ... +90°C [-58°F ... +194°F]	Limes, 365X, 368X SSI and analogue Safety-M		
	<b>Bending radius</b>	flexible installation min. 111 mm [4.37"] secure installation min. 55 mm [2.17"]			
	<b>Cable diameter</b>	approx. 7.4 mm ±0.3 mm			
<b>10 core + shield</b>					
<b>PUR electronic trailing cable halogen-free</b>  	<b>Cross section</b>	4 x 2 x 0.25 mm <sup>2</sup> [AWG23] + 2 x 1 mm <sup>2</sup> [AWG17]	suitable for:	<b>8.0000.6400.XXXX</b> <sup>1)</sup>	
	<b>Permanent working temperature range</b>	flexible installation -40°C ... +90°C [-40°F ... +194°F] secure installation -50°C ... +90°C [-58°F ... +194°F]	H100, H120 LA10, LA50 Safety-M		
	<b>Bending radius</b>	flexible installation min. 95 mm [3.74"] secure installation min. 40 mm [1.57"]			
	<b>Cable diameter</b>	approx. 7.9 mm ±0.8 mm			















1) XXXX = cable length in meters (e.g. 10 m = 0010)

# Connection technology

Cable		Unprepared, cut to length			Order no.
<b>12 core + shield</b>					
<b>PUR electronic trailing cable halogen-free</b> 	<b>Cross section</b>		10 x 0.14 mm <sup>2</sup> [AWG25] + 2 x 0.5 mm <sup>2</sup> [AWG20]	suitable for:	<b>8.0000.6100.XXXX</b> <sup>1)</sup>
	<b>Permanent working temperature range</b>	flexible installation secure installation	-30°C ... +80°C [-22°F ... +176°F] -50°C ... +90°C [-58°F ... +194°F]	robust incremental encoders	
 	<b>Bending radius</b>	flexible installation secure installation	min. 50 mm [1.97"] min. 35 mm [1.38"]		
	<b>Cable diameter</b>		approx. 6.9 mm ±0.3 mm		
<b>PVC electronic cable LiYCY</b> 	<b>Cross section</b>		12 x 0.14 mm <sup>2</sup> [AWG25]	suitable for:	<b>8.0000.6200.XXXX</b> <sup>1)</sup>
	<b>Permanent working temperature range</b>	flexible installation secure installation	-10°C ... +90°C [+14°F ... +194°F] -30°C ... +90°C [-22°F ... +194°F]	incremental encoders standard cable	
	<b>Bending radius</b>	flexible installation secure installation	min. 100 mm [3.94"] min. 65 mm [2.56"]		
	<b>Cable diameter</b>		approx. 6.7 mm ±0.2 mm		
<b>PUR electronic trailing cable halogen-free</b> 	<b>Cross section</b>		6 x 2 x 0.14 mm <sup>2</sup> [AWG25]	suitable for:	<b>8.0000.6Y00.XXXX</b> <sup>1)</sup>
	<b>Permanent working temperature range</b>	flexible installation secure installation	-30°C ... +90°C [-22°F ... +194°F] -40°C ... +90°C [-40°F ... +194°F]	robust incremental encoders LA10	
  	<b>Bending radius</b>	flexible installation secure installation	min. 90 mm [3.54"] min. 40 mm [1.57"]		
	<b>Cable diameter</b>		approx. 7.5 mm ±0.2 mm		
<b>TPE electronic cable halogen-free</b> 	<b>Cross section</b>		5 x 2 x 0.14 mm <sup>2</sup> + 2 x 0.5 mm <sup>2</sup>	suitable for:	<b>8.0000.6E00.XXXX</b> <sup>1)</sup>
	<b>Permanent working temperature range</b>	flexible installation secure installation	-25°C ... +110°C [-13°F ... +230°F] -40°C ... +135°C [-40°F ... +275°F]	high temperatures or encoders with sine wave output	
 	<b>Bending radius</b>	flexible installation secure installation	min. 90 mm [3.54"] min. 70 mm [2.76"]		
	<b>Cable diameter</b>		approx. 8.5 mm ±0.9 mm		
<b>PVC electronic cable LiYCY</b> 	<b>Cross section</b>		6 x 2 x 0.14 mm <sup>2</sup> [AWG25]	suitable for:	<b>8.0000.6900.XXXX</b> <sup>1)</sup>
	<b>Permanent working temperature range</b>	flexible installation secure installation	-5°C ... +70°C [+23°F ... +158°F] -30°C ... +80°C [-22°F ... +176°F]	absolute encoders with SSI or 4 ... 20 mA analogue output, twisted pair conductors	
	<b>Bending radius</b>	flexible installation secure installation	min. 110 mm [4.33"] min. 75 mm [2.95"]		
	<b>Cable diameter</b>		approx. 7.3 mm ±0.2 mm		
<b>18 core + shield</b>					
<b>PVC electronic cable LiYCY</b> 	<b>Cross section</b>		18 x 0.14 mm <sup>2</sup> [AWG25]	suitable for:	<b>8.0000.6700.XXXX</b> <sup>1)</sup>
	<b>Permanent working temperature range</b>	flexible installation secure installation	-5°C ... +70°C [+23°F ... +158°F] -30°C ... +80°C [-22°F ... +176°F]	absolute encoders with parallel output, twisted pair conductors	
	<b>Bending radius</b>	flexible installation secure installation	min. 120 mm [4.72"] min. 100 mm [3.94"]		
	<b>Cable diameter</b>		approx. 7.8 mm ±0.2 mm		







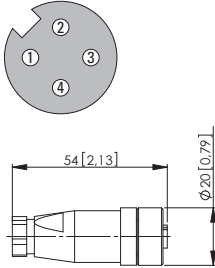

1) XXXX = cable length in meters (e.g. 10 m = 0010)

# Connection technology

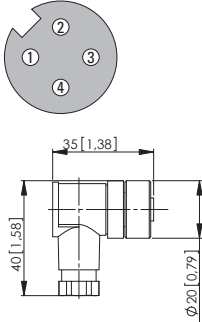

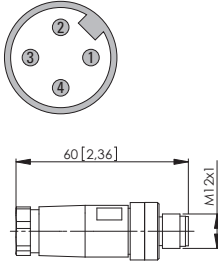

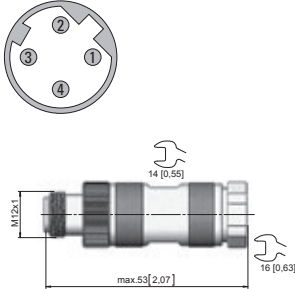

Cable		Unprepared, cut to length		
<b>PROFIBUS DP - cable</b>				Order no.
<b>PUR outer jacket, PE wire insulation halogen-free</b>  	<b>Cross section</b>	2 x 0.34 mm <sup>2</sup> [AWG22]	suitable for:	<b>05.KABEL451.XXX</b> <sup>1)</sup>
	<b>Permanent working temperature range</b>	flexible installation -25°C ... +60°C [-13°F ... +140°F] secure installation -50°C ... +90°C [-58°F ... +194°F]	all Profibus fieldbus encoders, Safety-M BM31, Safety-M modular SMBU and SMBS	
	<b>Bending radius</b>	flexible installation min. 80 mm [3.15"] secure installation min. 40 mm [1.57"]		
	<b>Cable diameter</b>	approx. 7.6 mm ±0.2 mm		
<b>DeviceNet - cable</b>				Order no.
<b>PUR outer jacket, PE wire insulation</b>  	<b>Cross section</b>	2 x 0.52 mm <sup>2</sup> [AWG24] + 2 x 1.04 mm <sup>2</sup> [AWG17]	suitable for:	<b>05.KABEL5723.XXX</b> <sup>1)</sup>
	<b>Permanent working temperature range</b>	flexible installation -30°C ... +70°C [-22°F ... +158°F] secure installation -40°C ... +80°C [-40°F ... +176°F]	all DeviceNet fieldbus encoders, Safety-M BM11	
	<b>Bending radius</b>	flexible installation min. 70 mm [2.76"] secure installation min. 50 mm [1.97"]		
	<b>Cable diameter</b>	approx. 8.4 mm ±0.2 mm		
<b>CANopen - cable</b>				Order no.
<b>PVC electronic cable</b>  	<b>Cross section</b>	3 x 2 x 0.25 mm <sup>2</sup> [AWG23]	suitable for:	<b>8.0000.6V00.XXXX</b> <sup>1)</sup>
	<b>Permanent working temperature range</b>	flexible installation -10°C ... +90°C [+14°F ... +194°F] secure installation -30°C ... +90°C [-22°F ... +194°F]	all CANopen fieldbus encoders, Safety-M BM21, Safety-M modular SMBU	
	<b>Bending radius</b>	flexible installation min. 130 mm [5.12"] secure installation min. 60 mm [2.36"]		
	<b>Cable diameter</b>	approx. 6.2 mm ±0.2 mm		
<b>Industrial EtherNet - cable</b>				Order no.
<b>PUR electronic cable</b>  	<b>Cross section</b>	2 x 2 x 0.34 mm <sup>2</sup> [AWG22]	suitable for:	<b>05.00.6031.1111.XXXM</b> <sup>1)</sup>
	<b>Permanent working temperature range</b>	flexible installation -30°C ... +70°C [-22°F ... +158°F] secure installation -40°C ... +80°C [-40°F ... +176°F]	all EtherCAT / PROFINET IO / EtherNet IP encoders, Safety-M BMB1 and BMC1, Safety-M modular SMBU and SMBS	
	<b>Bending radius</b>	flexible installation min. 50 mm [1.97"] secure installation min. 25 mm [0.98"]		
	<b>Cable diameter</b>	approx. 4.8 mm ±0.2 mm	  	

1) XXXX = cable length in meters (e.g. 10 m = 0010)

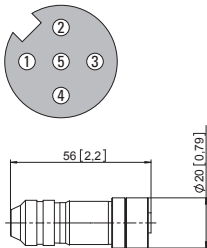

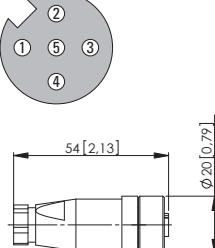

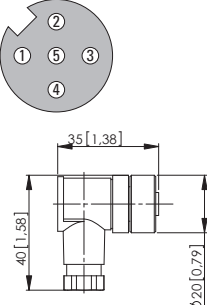

# Connection technology

M12 connection technology		Connectors, self-assembly		Order no.
<b>4 pin</b>				
<b>Female connector with coupling nut</b> <b>A coded, straight</b> <b>power supply</b> Housing: plastic, IP67 	screw connections, for cable $\varnothing$ 4 ... 6 mm [0.16 ... 0.24"] 	suitable for our series:  EMIO.SIO.10xP  5858 / 5878 5868 / 5888 9080	<b>05.B8141-0</b>	
<b>Female connector with coupling nut</b> <b>A coded, right-angle</b> <b>power supply</b> Housing: plastic, IP67 	screw connections, for cable $\varnothing$ 4 ... 6 mm [0.16 ... 0.24"] 	suitable for our series:  EMIO.SIO.10xP  5858 / 5878 5868 / 5888 9080	<b>05.B8241-0</b>	
<b>Male connector with external thread</b> <b>A coded, straight</b> <b>power supply</b> Housing: metal / plastic, IP67 	screw connections, for cable $\varnothing$ 4 ... 6 mm [0.16 ... 0.24"] 	suitable for:  versions with cable outlet	<b>05.BS8141-0</b>	
<b>Male connector with external thread</b> <b>D coded, straight</b> Housing: metal, IP67 	screw connections, for cable $\varnothing$ 4 ... 9 mm [0.16 ... 0.35"] 	suitable for our series:  5858 / 5878 5868 / 5888   Conformance tested  	<b>05.WASCSY4S</b>	

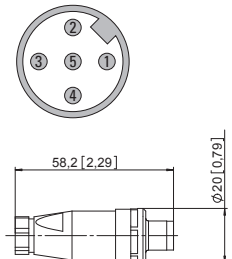
# Connection technology

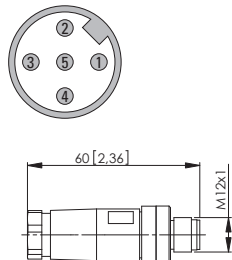

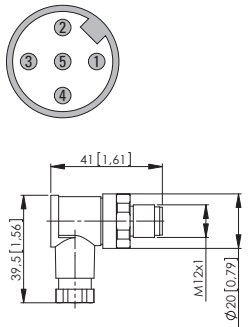



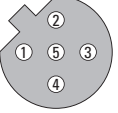
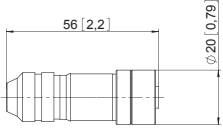

M12 connection technology		Connectors, self-assembly		Order no.
<b>5 pin</b>				
<b>Female connector with coupling nut</b> <b>A coded, straight</b> Housing: metal, IP67 	screw connections, for cable $\varnothing$ 6 ... 8 mm [0.24 ... 0.32"] 	suitable for our series: A50, B80, C120, D135, IS40 3651 / 3671  F3658 / F3658 F3668 / F3668 M3658 / M3678 M3668 / M3688 M3668R / M3688R F5868 / F5888 5858 / 5878 5868 / 5888 9080 IS60		<b>8.0000.5116.0000</b>
<b>Female connector with coupling nut</b> <b>A coded, straight</b> Housing: plastic, IP67 	screw connections, for cable $\varnothing$ 6 ... 8 mm [0.24 ... 0.32"] 	suitable for our series: A50, B80, C120, D135, IS40 3651 / 3671  9080 IS60		<b>05.B-8151-0/9</b>
<b>Female connector with coupling nut</b> <b>A coded, right-angle</b> Housing: plastic, IP67 	screw connections, for cable $\varnothing$ 6 ... 8 mm [0.24 ... 0.32"] 	suitable for our series: A50, B80, C120, D135, IS40 3651 / 3671  9080 IS60		<b>05.B-8251-0/9</b>

# Connection technology

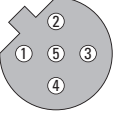
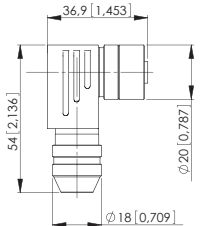
M12 connection technology		Connectors, self-assembly		Order no.
<b>5 pin</b>				
<p><b>Male connector with external thread</b> <b>A coded, straight</b></p> <p>Housing: metal, IP67</p> 	<p>screw connections, for cable <math>\varnothing</math> 6 ... 8 mm [0.24 ... 0.32"]</p> 	<p>suitable for our series:</p> <p>F3658 / F3658 F3668 / F3688 M3658 / M3678 M3668 / M3688 M3668R / M3688R F5868 / F5888 5858 / 5878 5868 / 5888 9080 IS60</p> 	<p><b>8.0000.5111.0000</b></p>	
<p><b>Male connector with external thread</b> <b>A coded, straight</b></p> <p>Housing: metal / plastic, IP67</p> 	<p>screw connections, for cable <math>\varnothing</math> 6 ... 8 mm [0.24 ... 0.32"]</p> 	<p>suitable for our series:</p> <p>9080 IS60</p> <p>EMIO.SIO.10xP</p> 	<p><b>05.BS-8151-0/9</b></p>	
<p><b>Male connector with external thread</b> <b>A coded, right-angle</b></p> <p>Housing: metal / plastic, IP67</p> 	<p>screw connections, for cable <math>\varnothing</math> 6 ... 8 mm [0.24 ... 0.32"]</p> 	<p>suitable for our series:</p> <p>9080 IS60</p> 	<p><b>05.BS-8251-0/9</b></p>	

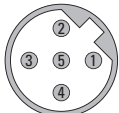
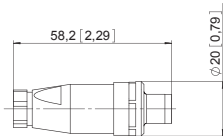
Connection technology

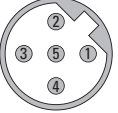
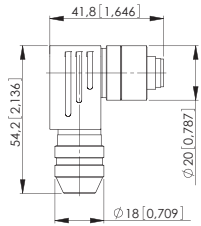



# Connection technology

M12 connection technology		Connectors, self-assembly		Order no.
<b>5 pin</b>				
<b>Female connector with coupling nut B coded, straight</b> Housing: metal, IP67 	screw connections, for cable $\varnothing$ 4 ... 9 mm [0.16 ... 0.35"]  	suitable for our series: 5858 / 5878 5868 / 5888 9080 	<b>05.BMWS 8151-8.5</b>	
<b>Female connector with coupling nut B coded, right-angle</b> Housing: metal, IP67 	screw connections, for cable $\varnothing$ 4 ... 9 mm [0.16 ... 0.35"]  	suitable for our series: 5858 / 5878 5868 / 5888 9080 	<b>05.BMWS 8251-8.5</b>	
<b>Male connector with external thread B coded, straight</b> Housing: metal, IP67 	screw connections, for cable $\varnothing$ 4 ... 9 mm [0.16 ... 0.35"]  	suitable for our series: 5858 / 5878 5868 / 5888 9080 	<b>05.BMSWS 8151-8.5</b>	
<b>Male connector with external thread B coded, right-angle</b> Housing: metal, IP67 	screw connections, for cable $\varnothing$ 4 ... 9 mm [0.16 ... 0.35"]  	suitable for our series: 5858 / 5878 5868 / 5888 9080 	<b>05.BMSWS 8251-8.5</b>	



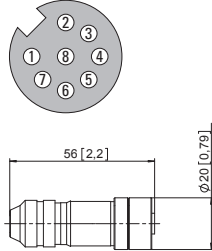

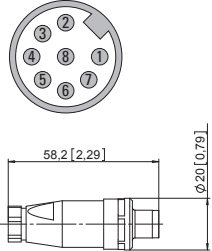

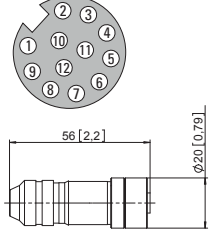



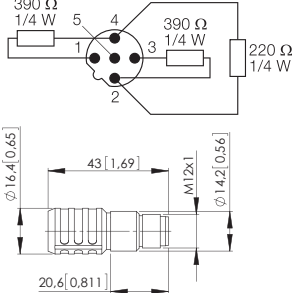

# Connection technology

## M12 connection technology Connectors, self-assembly

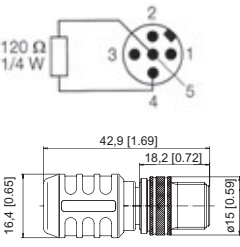
8 pin			Order no.												
<p><b>Female connector with coupling nut</b> <b>A coded, straight</b></p> <p>Housing: metal, IP67</p> 	<p>screw connections, for cable <math>\varnothing</math> 6 ... 8 mm [0.24 ... 0.32"]</p> 	<p>suitable for our series:</p> <table border="0"> <tr><td>3610 / 3620</td><td>5821</td></tr> <tr><td>F3653 / F3673</td><td>5814 / 5834</td></tr> <tr><td>F3663 / F3683</td><td>5853 / 5873</td></tr> <tr><td>5000 / 5020</td><td>5863 / 5883</td></tr> <tr><td>5006 / 5026</td><td>58x4FSx</td></tr> <tr><td>A020 / A02H</td><td>5876</td></tr> </table>	3610 / 3620	5821	F3653 / F3673	5814 / 5834	F3663 / F3683	5853 / 5873	5000 / 5020	5863 / 5883	5006 / 5026	58x4FSx	A020 / A02H	5876	<b>05.CMB 8181-0</b>
3610 / 3620	5821														
F3653 / F3673	5814 / 5834														
F3663 / F3683	5853 / 5873														
5000 / 5020	5863 / 5883														
5006 / 5026	58x4FSx														
A020 / A02H	5876														
<p><b>Male connector with external thread</b> <b>A coded, straight</b></p> <p>Housing: metal, IP67</p> 	<p>screw connections, for cable <math>\varnothing</math> 6 ... 8 mm [0.24 ... 0.32"]</p> 	<p>suitable for: versions with cable outlet</p>	<b>05.CMBS 8181-0</b>												
12 pin			Order no.												
<p><b>Female connector with coupling nut</b> <b>A coded, straight</b></p> <p>Housing: metal, IP67</p> 	<p>screw connections, for cable <math>\varnothing</math> 6 ... 8 mm [0.24 ... 0.32"]</p> 	<p>suitable for: LA10</p>	<b>8.0000.5162.0000</b>												

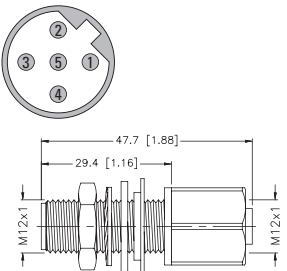
# Connection technology

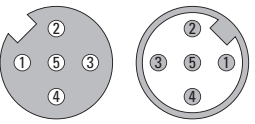
## M12 connection technology **Connectors, self-assembly**

Accessories		Order no.	
<p><b>Securing clip for M12 connectors</b></p> <p>Material: plastic</p> 	<p>against accidental disconnection under load</p> <p>working temperature range -25°C ... +90°C [-13°F ... +194°F]</p>	<p><b>8.0000.5000.0006</b></p>	
<p><b>Terminating resistor</b> <b>Male connector with external thread</b> <b>B coded, straight</b></p> <p>Housing: metal / plastic, IP67</p> 	 <p>390 Ω 1/4 W</p> <p>220 Ω 1/4 W</p> <p>Dimensions: 43 [1.69], 20.6 [0.811], 16.4 [0.65], 1.42 [0.56], M12x1</p>	<p>suitable for our series:</p> <p>5858 / 5878 5868 / 5888 9080</p> 	<p><b>05.RSS4.5-PDP-TR</b></p>
<p><b>Terminating resistor</b> <b>Male connector with external thread</b> <b>A coded, straight</b></p> <p>Housing: metal / plastic, IP67</p> 	 <p>120 Ω 1/4 W</p> <p>Dimensions: 42.9 [1.69], 18.2 [0.72], 16.4 [0.65], 1.5 [0.58], 1.5 [0.58]</p>	<p>suitable for our series:</p> <p>F5868 / F5888 5858 / 5878 5868 / 5888 9080</p> 	<p><b>05.RSE 57 TR2</b></p>
<p><b>M12 lead-through</b> <b>B coded, straight</b></p> <p>Housing: metal, IP67</p> 	 <p>Dimensions: 47.7 [1.88], 29.4 [1.16], M12x1</p>	<p>suitable for our series:</p> <p>5858 / 5878 5868 / 5888 9080</p> 	<p><b>05.FKW-FSW45/M12</b></p>
<p><b>T-junction</b> <b>A coded, 5 pin</b></p> <p>Housing: metal / plastic, IP67</p> 	<p>2 x female connector with coupling nut 1 x male connector with external thread</p> 	<p>suitable for:</p> <p>M12 connectors</p> 	<p><b>05.FKM5-FKM5-FSM5</b></p>

# Connection technology

## M12 connection technology Cordsets, pre-assembled

**With connector, 4 pin** Working temp. -30°C ... +80°C [-22°F ... +176°F] Order no.

**Female connector with coupling nut + single-ended A coded, straight power supply**

Cable: PUR, 4 x 0.34 mm<sup>2</sup> [AWG22]  
Housing: metal / plastic, IP67

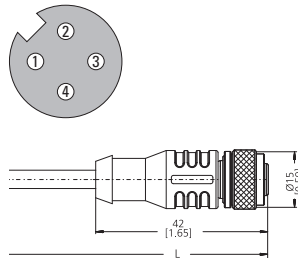

Terminal assignment

Pin female contacts:	1	2	3	4
Wire colour:	BN	WH	BU	BK

suitable for our series:

EMIO.SIO.10xP  
5858 / 5878  
5868 / 5888  
9080

Cable length <sup>1)</sup>

2 m [6.56']	<b>05.00.6061.6211.002M</b>
5 m [16.40']	<b>05.00.6061.6211.005M</b>
10 m [32.81']	<b>05.00.6061.6211.010M</b>
15 m [49.21']	<b>05.00.6061.6211.015M</b>

**Female connector with coupling nut + male connector with external thread A coded, straight power supply**

Cable: PUR, 4 x 0.34 mm<sup>2</sup> [AWG22]  
Housing: metal / plastic, IP67

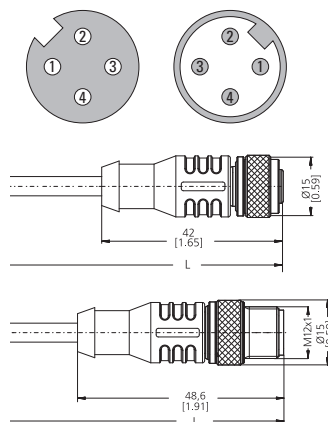

suitable for our series:

EMIO.SIO.10xP  
5858 / 5878  
5868 / 5888  
9080

Cable length <sup>1)</sup>

2 m [6.56']	<b>05.00.6061.6462.002M</b>
5 m [16.40']	<b>05.00.6061.6462.005M</b>
10 m [32.81']	<b>05.00.6061.6462.010M</b>
15 m [49.21']	<b>05.00.6061.6462.015M</b>

1) Other cable lengths on request.

# Connection technology

## M12 connection technology Cordsets, pre-assembled

**With connector, 4 pin** Working temp. -30°C ... +80°C [-22°F ... +176°F] Order no.

**Male connector with external thread**  
**single-ended**  
**D coded, straight**

Cable: PUR, 2 x 2 x 0.34 mm<sup>2</sup> [AWG22]  
 Housing: metal /plastic, IP67



Port A (1) and B (2)

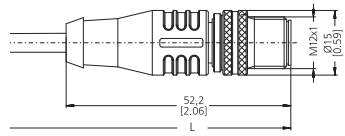
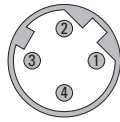

suitable for our series:

5858 / 5878  
 5868 / 5888



Terminal assignment

Pin male contacts:	1	2	3	4
Wire colour:	YE	OG	WH	BU

Cable length <sup>1)</sup>

2 m [6.56']	<b>05.00.6031.4411.002M</b>
5 m [16.40']	<b>05.00.6031.4411.005M</b>
10 m [32.81']	<b>05.00.6031.4411.010M</b>
15 m [49.21']	<b>05.00.6031.4411.015M</b>

1) Other cable lengths on request.

# Connection technology

## M12 connection technology Cordsets, pre-assembled

With connector, 5 pin Working temp. -30°C ... +80°C [-22°F ... +176°F] Order no.

**Female connector with coupling nut + single-ended A coded, straight**

Cable: PVC, 5 x 0.25 mm<sup>2</sup> [AWG23]  
Housing: metal / plastic, IP67



Terminal assignment

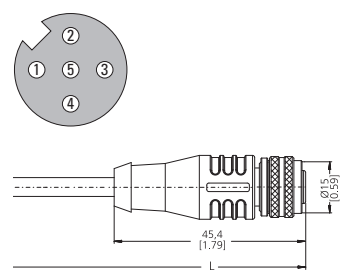

suitable for our series:  
  
A50, B80, C120, D135  
IS40

Pin female contacts:	1	2	3	4	5	PH <sup>2)</sup>
Wire colour:	BN	WH	BU	BK	GY	PH <sup>2)</sup>

Cable length<sup>1)</sup>  
2 m [6.56']  
5 m [16.40']  
10 m [32.81']  
15 m [49.21']

**05.00.6081.2211.002M**  
**05.00.6081.2211.005M**  
**05.00.6081.2211.010M**  
**05.00.6081.2211.015M**

**Female connector with coupling nut + single-ended A coded, straight**

Cable: PUR, 4 x 0.34 mm<sup>2</sup> [AWG22]  
Housing: metal / plastic, IP67



Terminal assignment

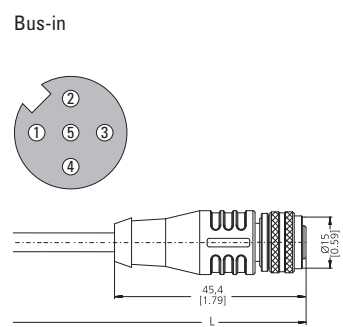

suitable for our series:  
  
9080  
IS60

**DeviceNet**

Pin female contacts:	1	2	3	4	5
Wire colour:	± 3)	RD	BK	WH	BU

Cable length<sup>1)</sup>  
2 m [6.56']  
5 m [16.40']  
10 m [32.81']  
15 m [49.21']

**05.00.6021.2211.002M**  
**05.00.6021.2211.005M**  
**05.00.6021.2211.010M**  
**05.00.6021.2211.015M**

**Female connector with coupling nut + single-ended A coded, straight**

Cable: PVC, 3 x 2 x 0.25 mm<sup>2</sup>  
Housing: metal / plastic, IP67



Terminal assignment

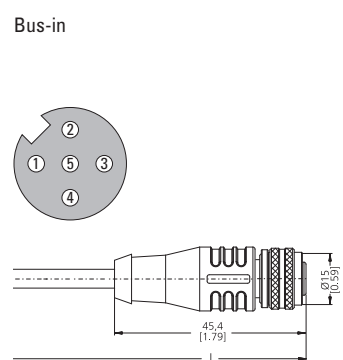

suitable for our series:  
  
M3658 / M3678  
F5868 / F5888  
5858 / 5878  
5868 / 5888

**CANopen**

Pin female contacts:	1	2	3	4	5	PH <sup>2)</sup>
Wire colour:	GY	BN	WH	GN	YE	PH <sup>2)</sup>

Cable length<sup>1)</sup>  
2 m [6.56']  
5 m [16.40']  
10 m [32.81']  
15 m [49.21']

**05.00.6091.A211.002M**  
**05.00.6091.A211.005M**  
**05.00.6091.A211.010M**  
**05.00.6091.A211.015M**

1) Other cable lengths on request.  
2) Shield on housing.  
3) Shield with pin 1.

Connection technology

# Connection technology

## M12 connection technology

## Cordsets, pre-assembled

With connector, 5 pin

Working temp. -30°C ... +80°C [-22°F ... +176°F]

Order no.

**Male connector with external thread + single-ended**  
**A coded, straight**

Cable: PUR, 4 x 0.34 mm<sup>2</sup> [AWG22]  
Housing: metal / plastic, IP67



Bus out

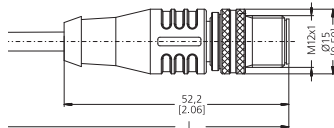
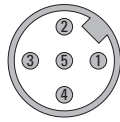

suitable for our series:

9080  
IS60

**DeviceNet.**

Terminal assignment

Pin male contacts:	1	2	3	4	5
Wire colour:	⊥ <sup>3)</sup>	RD	BK	WH	BU

Cable length <sup>1)</sup>

2 m [6.56']  
5 m [16.40']  
10 m [32.81']  
15 m [49.21']

**05.00.6021.2411.002M**  
**05.00.6021.2411.005M**  
**05.00.6021.2411.010M**  
**05.00.6021.2411.015M**

**Male connector with external thread + single-ended**  
**A coded, straight**

Cable: PVC, 3 x 2 x 0.25 mm<sup>2</sup> [AWG23]  
Housing: metal / plastic, IP67



Bus out

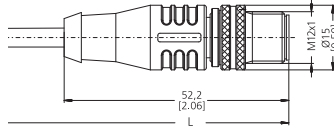
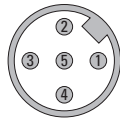

suitable for our series:

EMIO.SIO.10xP  
M3658 / M3678  
F5868 / F5888  
5858 / 5878  
5868 / 5888

**CANopen**

Terminal assignment

Pin male contacts:	1	2	3	4	5	PH <sup>2)</sup>
Wire colour:	GY	BN	WH	GN	YE	PH <sup>2)</sup>

Cable length <sup>1)</sup>



2 m [6.56']  
5 m [16.40']  
10 m [32.81']  
15 m [49.21']

**05.00.6091.A411.002M**  
**05.00.6091.A411.005M**  
**05.00.6091.A411.010M**  
**05.00.6091.A411.015M**

1) Other cable lengths on request.  
2) Shield on housing.  
3) Shield with pin 1.

# Connection technology

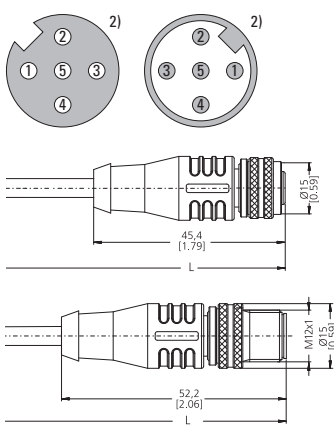
## M12 connection technology Cordsets, pre-assembled

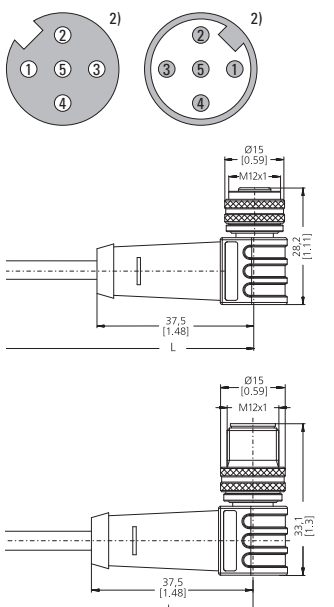
With connector, 5 pin		Working temp. -30°C ... +80°C [-22°F ... +176°F]	Order no.
<p><b>Female connector with coupling nut + male connector with external thread A coded, straight</b></p> <p>Cable: PUR, 4 x 0.34 mm<sup>2</sup> [AWG22] Housing: metal / plastic, IP67</p> 	<p>Bus in / out</p> 	<p>suitable for our series:</p> <p>EMIO.SIO.10xP</p> <p>9080</p> <p><b>DeviceNet.</b></p> <p><i>Cable length <sup>1)</sup></i></p> <ul style="list-style-type: none"> <li>2 m [6.56']</li> <li>5 m [16.40']</li> <li>10 m [32.81']</li> <li>15 m [49.21']</li> </ul>	<ul style="list-style-type: none"> <li><b>05.00.6021.2422.002M</b></li> <li><b>05.00.6021.2422.005M</b></li> <li><b>05.00.6021.2422.010M</b></li> <li><b>05.00.6021.2422.015M</b></li> </ul>
<p><b>Female connector with coupling nut + male connector with external thread A coded, right-angle</b></p> <p>Cable: PUR, 4 x 0.34 mm<sup>2</sup> [AWG22] Housing: metal / plastic, IP67</p> 	<p>Bus in / out</p> 	<p>suitable for our series:</p> <p>9080</p> <p><b>DeviceNet.</b></p> <p><i>Cable length <sup>1)</sup></i></p> <ul style="list-style-type: none"> <li>2 m [6.56']</li> <li>5 m [16.40']</li> <li>10 m [32.81']</li> <li>15 m [49.21']</li> </ul>	<ul style="list-style-type: none"> <li><b>05.00.6021.2523.002M</b></li> <li><b>05.00.6021.2523.005M</b></li> <li><b>05.00.6021.2523.010M</b></li> <li><b>05.00.6021.2523.015M</b></li> </ul>

1) Other cable lengths on request.  
2) Shield with pin 1.

# Connection technology

## M12 connection technology Cordsets, pre-assembled

With connector, 5 pin Working temp. -30°C ... +80°C [-22°F ... +176°F] Order no.

**Female connector with coupling nut + single-ended**  
**B coded, straight**

Cable: PUR, 2 x 0.34 mm<sup>2</sup>  
 Housing: metal / plastic, IP67



Bus in

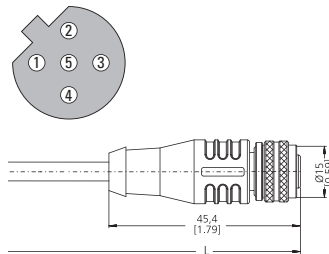

suitable for our series:

5858 / 5878  
 5868 / 5888  
 9080



Terminal assignment

Pin female contacts:	1	2	3	4	5	PH 2)
Wire colour:	n.c.	GN	n.c.	RD	n.c.	PH 2)

Cable length 1)

2 m [6.56']  
 5 m [16.40']  
 10 m [32.81']  
 15 m [49.21']

**05.00.6011.3211.002M**  
**05.00.6011.3211.005M**  
**05.00.6011.3211.010M**  
**05.00.6011.3211.015M**

**Female connector with coupling nut + single-ended**  
**B coded, right-angle**

Cable: PUR, 2 x 0.34 mm<sup>2</sup> [AWG22]  
 Housing: metal / plastic, IP67



Bus in

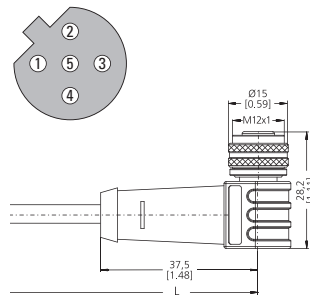

suitable for our series:

5858 / 5878  
 5868 / 5888  
 9080



Terminal assignment

Pin female contacts:	1	2	3	4	5	PH 2)
Wire colour:	n.c.	GN	n.c.	RD	n.c.	PH 2)

Cable length 1)

2 m [6.56']  
 5 m [16.40']  
 10 m [32.81']  
 15 m [49.21']

**05.00.6011.3311.002M**  
**05.00.6011.3311.005M**  
**05.00.6011.3311.010M**  
**05.00.6011.3311.015M**

1) Other cable lengths on request.  
 2) Shield on housing.



# Connection technology

## M12 connection technology Cordsets, pre-assembled

**With connector, 5 pin** Working temp. -30°C ... +80°C [-22°F ... +176°F] Order no.

**Male connector with external thread + single-ended**  
**B coded, straight**

Cable: PUR, 2 x 0.34 mm<sup>2</sup>  
Housing: metal / plastic, IP67



Bus out

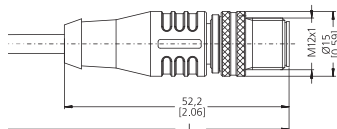
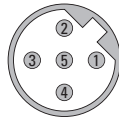

suitable for our series:

5858 / 5878  
5868 / 5888  
9080



Terminal assignment

Pin male contacts:	1	2	3	4	5	PH <sup>2)</sup>
Wire colour:	n.c.	GN	n.c.	RD	n.c.	PH <sup>2)</sup>

Cable length<sup>1)</sup>

2 m [6.56']  
5 m [16.40']  
10 m [32.81']  
15 m [49.21']

**05.00.6011.3411.002M**  
**05.00.6011.3411.005M**  
**05.00.6011.3411.010M**  
**05.00.6011.3411.015M**

**Male connector with external thread + single-ended**  
**B coded, right-angle**

Cable: PUR, 2 x 0.34 mm<sup>2</sup>  
Housing: metal / plastic, IP67



Bus out

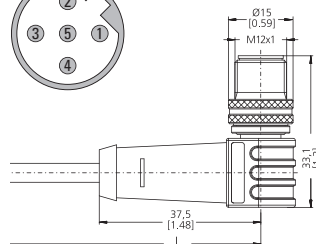
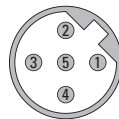

suitable for our series:

5858 / 5878  
5868 / 5888  
9080



Terminal assignment

Pin male contacts:	1	2	3	4	5	PH <sup>2)</sup>
Wire colour:	n.c.	GN	n.c.	RD	n.c.	PH <sup>2)</sup>

Cable length<sup>1)</sup>

2 m [6.56']  
5 m [16.40']  
10 m [32.81']  
15 m [49.21']

**05.00.6011.3511.002M**  
**05.00.6011.3511.005M**  
**05.00.6011.3511.010M**  
**05.00.6011.3511.015M**

1) Other cable lengths on request.  
2) Shield on housing.

# Connection technology

## M12 connection technology

## Cordsets, pre-assembled

With connector, 5 pin

Working temp. -30°C ... +80°C [-22°F ... +176°F]

Order no.

**Female connector with coupling nut + male connector with external thread B coded, straight**

Cable: PUR, 2 x 0.34 mm<sup>2</sup>  
Housing: metal / plastic, IP67



Bus in / out

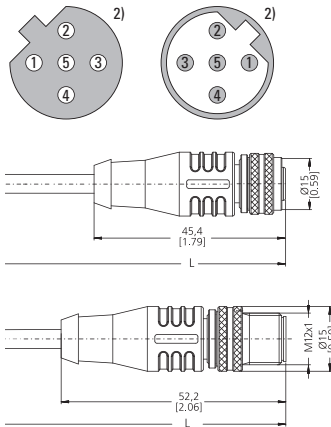

suitable for our series:

5858 / 5878  
5868 / 5888  
9080



Cable length <sup>1)</sup>

2 m [6.56']  
5 m [16.40']  
10 m [32.81']  
15 m [49.21']

**05.00.6011.3432.002M**  
**05.00.6011.3432.005M**  
**05.00.6011.3432.010M**  
**05.00.6011.3432.015M**

**Female connector with coupling nut + male connector with external thread B coded, right-angle**

Cable: PUR, 2 x 0.34 mm<sup>2</sup>  
Housing: metal / plastic, IP67



Bus in / out

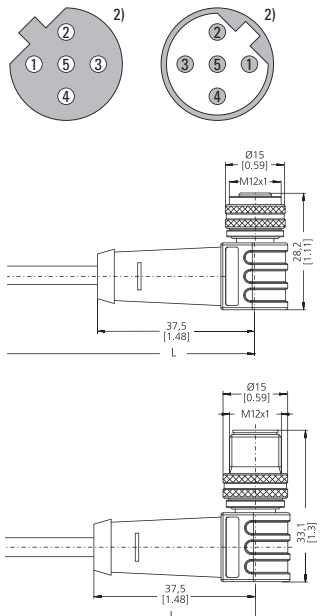

suitable for our series:

5858 / 5878  
5868 / 5888  
9080



Cable length <sup>1)</sup>

2 m [6.56']  
5 m [16.40']  
10 m [32.81']  
15 m [49.21']

**05.00.6011.3533.002M**  
**05.00.6011.3533.005M**  
**05.00.6011.3533.010M**  
**05.00.6011.3533.015M**

1) Other cable lengths on request.  
2) Shield on housing.

# Connection technology

## M12 connection technology Cordsets, pre-assembled

With connector, 8 pin Working temp. -30°C ... +80°C [-22°F ... +176°F] Order no.

**Female connector with coupling nut + single-ended A coded, straight**

Cable: PVC, 8 x 0.25 mm<sup>2</sup> [AWG23]  
Housing: metal / plastic, IP67

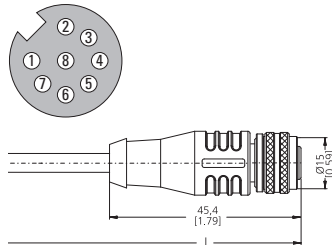

suitable for our series:

- 3610 / 3620      5000 / 5020
- 5814 / 5834      5814FSx / 5834FSx
- 5006 / 5026      5821
- A020 / A02H
- F3653 / F3673
- 5853 / 5873
- M3663 / M3683    M3663R / M3683R
- F3663 / F3683    F5863 / F5883
- 5863 / 5883
- 5876

Terminal assignment

Pin female contacts:	1	2	3	4	5	6	7	8	PH <sup>2)</sup>
Wire colour:	WH	BN	GN	YE	GY	PK	BU	RD	PH <sup>2)</sup>

Cable length <sup>1)</sup>

- 2 m [6.56']      **05.00.6041.8211.002M**
- 5 m [16.40']      **05.00.6041.8211.005M**
- 10 m [32.81']      **05.00.6041.8211.010M**
- 15 m [49.21']      **05.00.6041.8211.015M**

**Female connector with coupling nut + single-ended A coded, straight**

Cable: PUR, 8 x 0.25 mm<sup>2</sup> [AWG23]  
Housing: metal / plastic, IP67

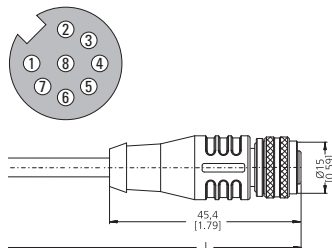

suitable for our series:

- 3610 / 3620      5000 / 5020
- 5814 / 5834      5814FSx / 5834FSx
- 5006 / 5026      5821
- A020 / A02H
- F3653 / F3673
- 5853 / 5873
- M3663 / M3683    M3663R / M3683R
- F3663 / F3683    F5863 / F5883
- 5863 / 5883
- 5876

Terminal assignment

Pin female contacts:	1	2	3	4	5	6	7	8	PH <sup>2)</sup>
Wire colour:	WH	BN	GN	YE	GY	PK	BU	RD	PH <sup>2)</sup>

Cable length <sup>1)</sup>

- 2 m [6.56']      **05.00.6051.8211.002M**
- 5 m [16.40']      **05.00.6051.8211.005M**
- 10 m [32.81']      **05.00.6051.8211.010M**
- 15 m [49.21']      **05.00.6051.8211.015M**

**Female connector with coupling nut + single-ended A coded, right-angle**

Cable: PVC, 8 x 0.25 mm<sup>2</sup> [AWG23]  
Housing: metal / plastic, IP67

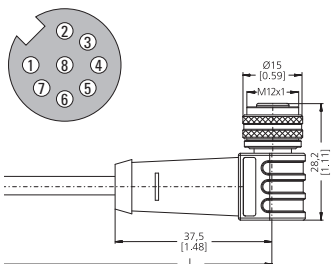

suitable for our series:

- 3610 / 3620      5000 / 5020
- 5814 / 5834      5814FSx / 5834FSx
- 5006 / 5026      5821
- A020 / A02H
- F3653 / F3673
- 5853 / 5873
- M3663 / M3683    M3663R / M3683R
- F3663 / F3683    F5863 / F5883
- 5863 / 5883
- 5876

Terminal assignment

Pin female contacts:	1	2	3	4	5	6	7	8	PH <sup>2)</sup>
Wire colour:	WH	BN	GN	YE	GY	PK	BU	RD	PH <sup>2)</sup>

Cable length <sup>1)</sup>

- 2 m [6.56']      **05.00.6041.8311.002M**
- 5 m [16.40']      **05.00.6041.8311.005M**
- 10 m [32.81']      **05.00.6041.8311.010M**
- 15 m [49.21']      **05.00.6041.8311.015M**

1) Other cable lengths on request.  
2) Shield on housing.

## M12 connection technology Cordsets, pre-assembled

**With connector, 8 pin** Working temp. -30°C ... +80°C [-22°F ... +176°F] Order no.

**Female connector with coupling nut + single-ended**  
**A coded, right-angle**  
**with integrated control LEDs**

Cable: PVC, 8 x 0.25 mm<sup>2</sup> [AWG23]  
 Housing: metal / plastic, IP67

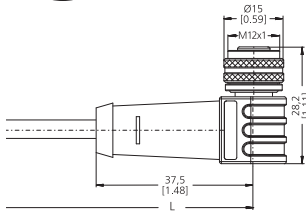
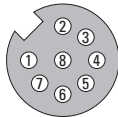

suitable for our series:

3610 / 3620 5006  
 5000 / 5020 5821  
 A020 A02H

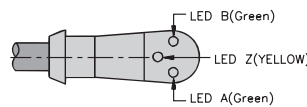

Terminal assignment

Pin female contacts:	1	2	3	4	5	6	7	8	PH 2)
Wire colour:	WH	BN	YE	GN	PK	GY	RD	BU	PH 2)

Cable length 1)

2 m [6.56']  
 5 m [16.40']  
 10 m [32.81']  
 15 m [49.21']

**05.E-WKC 8T-PX3-930-0002**  
**05.E-WKC 8T-PX3-930-0005**  
**05.E-WKC 8T-PX3-930-0010**  
**05.E-WKC 8T-PX3-930-0015**

**With connector, 12 pin** Working temp. -30°C ... +90°C [-22°F ... +194°F] Order no.

**Female connector with coupling nut + single-ended**  
**A coded, straight**

Cable: PUR, 6 x 2 x 0.14 mm<sup>2</sup>  
 Housing: metal / plastic, IP67

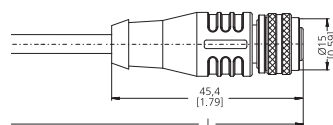
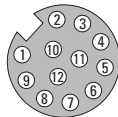

suitable for our series:

LA10

Terminal assignment

Pin female contacts:	1	2	3	4	5	6	7	8	9	10	11	12	PH 2)
Wire colour:	WH	BN	GN	YE	GY	PK	BU	RD	BK	VT	GY/PK	RD/BU	PH 2)





Cable length 1)

2 m [6.56']  
 5 m [16.40']  
 10 m [32.81']  
 15 m [49.21']

**05.00.60B1.B211.002M**  
**05.00.60B1.B211.005M**  
**05.00.60B1.B211.010M**  
**05.00.60B1.B211.015M**

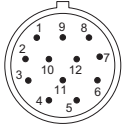
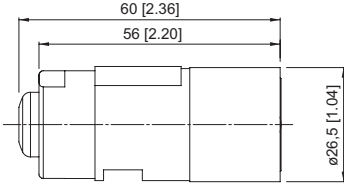
1) Other cable lengths on request.  
 2) Shield on housing.

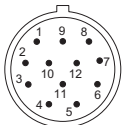
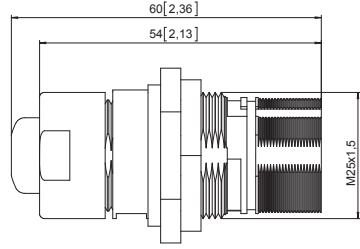

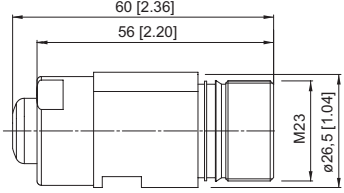
# Connection technology



M23 connection technology		Connectors, self-assembly		Order no.
<b>12 pin</b>				
<p><b>Male connector with external thread</b> pin assignment ccw</p> <p>Housing: metal, IP67</p> 	<p>solder connections, for cable <math>\varnothing</math> 5.5 ... 10.5 mm [0.22 ... 0.41"]</p>  	<p>suitable for:</p> <p>versions with cable outlet</p>	<p><b>8.0000.5015.0001</b></p>	
<p><b>Male connector with external thread</b> pin assignment ccw central fastening</p> <p>Housing: metal, IP67</p> 	<p>solder connections, for cable <math>\varnothing</math> 5.5 ... 10.5 mm [0.22 ... 0.41"]</p>  	<p>suitable for:</p> <p>versions with cable outlet</p>	<p><b>8.0000.5015.0000</b></p>	
<p><b>Female connector with coupling nut</b> pin socket assignment cw</p> <p>Housing: metal, IP67</p> 	<p>solder connections, for cable <math>\varnothing</math> 5.5 ... 10.5 mm [0.22 ... 0.41"]</p>  	<p>suitable for:</p> <p>5000 / 5020 580X / 582X            5814 / 5834 5814FSx / 5834FSx            F5863 / F5883            585x / 587x 5853FSx / 5873FSx            586x / 588x 5863FSx / 5883FSx            9000 908x            A02x</p>	<p><b>8.0000.5012.0000</b></p>	

Connection technology

# Connection technology

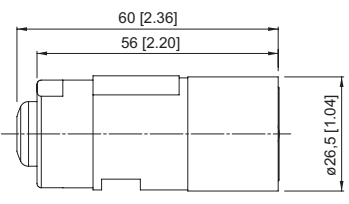
## M23 connection technology **Connectors, self-assembly**

12 pin			Order no.														
<p><b>Female connector with coupling nut</b>  <b>pin socket assignment cw</b>            (EX zone 2/22 on request)</p> <p>Housing: metal, IP67</p> 	<p>solder connections,            for cable <math>\varnothing</math> 5.5 ... 10.5 mm [0.22 ... 0.41"]</p>  	<p>suitable for:</p> <table border="0"> <tr> <td>5000 / 5020</td> <td>580X / 582X</td> </tr> <tr> <td>5814 / 5834</td> <td>5814FSx / 5834FSx</td> </tr> <tr> <td>F5863 / F5883</td> <td></td> </tr> <tr> <td>585X / 587X</td> <td>5853FSx / 5873FSx</td> </tr> <tr> <td>586X / 588X</td> <td>5863FSx / 5883FSx</td> </tr> <tr> <td>9000</td> <td>908X</td> </tr> <tr> <td>A02X</td> <td></td> </tr> </table>	5000 / 5020	580X / 582X	5814 / 5834	5814FSx / 5834FSx	F5863 / F5883		585X / 587X	5853FSx / 5873FSx	586X / 588X	5863FSx / 5883FSx	9000	908X	A02X		<p><b>8.0000.5012.0000.Ex</b></p>
5000 / 5020	580X / 582X																
5814 / 5834	5814FSx / 5834FSx																
F5863 / F5883																	
585X / 587X	5853FSx / 5873FSx																
586X / 588X	5863FSx / 5883FSx																
9000	908X																
A02X																	

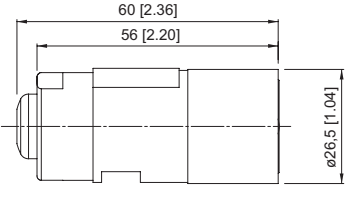
17 pin			Order no.				
<p><b>Female connector with coupling nut</b>  <b>pin socket assignment ccw</b></p> <p>Housing: metal, IP67</p> 	<p>solder connections,            for cable <math>\varnothing</math> 5.5 ... 10.5 mm [0.22 ... 0.41"]</p>  	<p>suitable for:</p> <table border="0"> <tr> <td>5850 / 5870</td> <td></td> </tr> <tr> <td>5852 / 5872</td> <td></td> </tr> </table>	5850 / 5870		5852 / 5872		<p><b>8.0000.5042.0000</b></p>
5850 / 5870							
5852 / 5872							

# Connection technology

## M23 connection technology Cordsets, pre-assembled

With connector, 12 pin Working temp. -30°C ... +80°C [-22°F ... +176°F] Order no.

### Female connector with coupling nut + single-ended

Cable: PVC, 6 x 2 x 0.14 mm<sup>2</sup> [AWG25]  
Housing: metal, IP67



### pin socket assignment cw

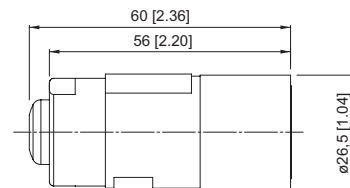

suitable for our series with RS422 or SinCos output:

5000 / 5020 5803 / 5823  
5804 / 5824 5805 / 5825  
5814 / 5834 5814FSx / 5834FSx  
A020 / A02H H120

### Terminal assignment

Pin female contacts:	1	2	3	4	5	6	7	8	9	10	11	12	PH <sup>2)</sup>
Wire colour:	PK	RD-BU	BU	RD	GN	YE	-	GY	-	WH	GY-PK	BN	PH <sup>2)</sup>

### Cable length<sup>1)</sup>

2 m [6.56']  
5 m [16.40']  
10 m [32.81']  
15 m [49.21']

**8.0000.6901.0002**  
**8.0000.6901.0005**  
**8.0000.6901.0010**  
**8.0000.6901.0015**

### Female connector with coupling nut + single-ended

Cable: PUR, 10 x 0.14 mm<sup>2</sup> [AWG25] +  
2 x 0.5 mm<sup>2</sup> [AWG20]  
Housing: metal, IP67



### pin socket assignment cw

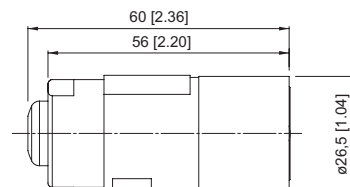

suitable for our series with RS422 or SinCos output:

5000 / 5020 5803 / 5823  
5804 / 5824 5805 / 5825  
5814 / 5834 5814FSx / 5834FSx  
A020 / A02H H120

### Terminal assignment

Pin female contacts:	1	2	3	4	5	6	7	8	9	10	11	12	PH <sup>2)</sup>
Wire colour:	PK	BN	BU	RD	GN	YE	-	GY	-	WH <sub>0.5 mm<sup>2</sup></sub>	WH	BN <sub>0.5 mm<sup>2</sup></sub>	PH <sup>2)</sup>

### Cable length<sup>1)</sup>

2 m [6.56']  
5 m [16.40']  
10 m [32.81']  
15 m [49.21']

**8.0000.6101.0002**  
**8.0000.6101.0005**  
**8.0000.6101.0010**  
**8.0000.6101.0015**

1) Other cable lengths on request.  
2) Shield on housing.

## M23 connection technology Cordsets, pre-assembled

With connector, 12 pin

Working temp. -30°C ... +80°C [-22°F ... +176°F]

Order no.

**Female connector with coupling nut + single-ended**

Cable: PVC, 6 x 2 x 0.14 mm<sup>2</sup> [AWG25]  
Housing: metal, IP67

pin socket assignment cw



suitable for our series with SSI or analogue output:

5850 / 5870	F5863 / F5883
5853 / 5873	5853FSx / 5873FSx
5863 / 5883	5863FSx / 5883FSx
9081	

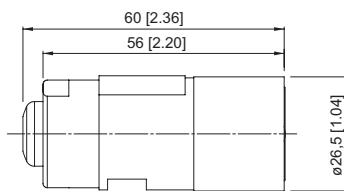

Terminal assignment

Cable length <sup>1)</sup>

Pin female contacts:	1	2	3	4	5	6	7	8	9	10	11	12	PH <sup>2)</sup>
Wire colour:	WH	BN	GN	YE	GY	PK	BU	RD	BK	VT	GY-PK	RD-BU	PH <sup>2)</sup>

2 m [6.56']

**8.0000.6901.0002.0031**

5 m [16.40']

**8.0000.6901.0005.0031**

10 m [32.81']

**8.0000.6901.0010.0031**

15 m [49.21']

**8.0000.6901.0015.0031**

1) Other cable lengths on request.  
2) Shield on housing.



# Connection technology

## M23 connection technology Cordsets, pre-assembled

With connector, 12 pin Working temp. -30°C ... +80°C [-22°F ... +176°F] Order no.

### Female connector with coupling nut + male connector with external thread

Cable: PVC, 6 x 2 x 0.14 mm<sup>2</sup> [AWG25]  
Housing: metal, IP67



### pin socket assignment cw



### pin socket assignment ccw

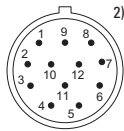

suitable for our series:

5000 / 5020 5803 / 5823  
5804 / 5824 5805 / 5825  
5814 / 5834 5814FSx / 5834FSx  
A020 / A02H H120

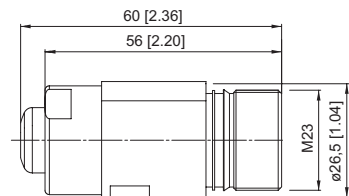
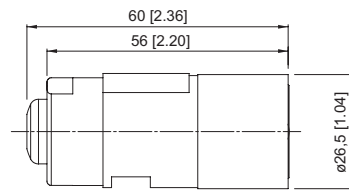

Cable length <sup>1)</sup>

2 m [6.56']  
5 m [16.40']  
10 m [32.81']  
15 m [49.21']

8.0000.6905.0002  
8.0000.6905.0005  
8.0000.6905.0010  
8.0000.6905.0015

### Female connector with coupling nut + male connector with external thread

Cable: PVC, 6 x 2 x 0.14 mm<sup>2</sup> [AWG25]  
Housing: metal, IP67



### pin socket assignment cw



### pin socket assignment ccw

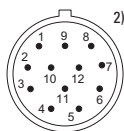

suitable for our series with SSI output:

5850 / 5870 F5863 / F5883  
5853 / 5873 5853FSx / 5873FSx  
5863 / 5883 5863FSx / 5883FSx  
9081

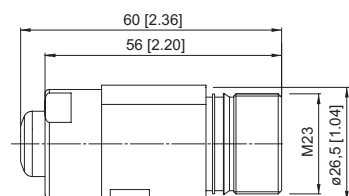
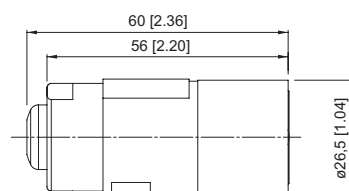

Cable length <sup>1)</sup>

2 m [6.56']  
5 m [16.40']  
10 m [32.81']  
15 m [49.21']

8.0000.6905.0002.0032  
8.0000.6905.0005.0032  
8.0000.6905.0010.0032  
8.0000.6905.0015.0032

1) Other cable lengths on request.  
2) Shield on housing.

## M23 connection technology Cordsets, pre-assembled

**With connector, 17 pin** Working temp. -30°C ... +80°C [-22°F ... +176°F] Order no.

**Female connector with coupling nut + single-ended**

Cable: PVC, 18 x 0.14 mm<sup>2</sup> [AWG25]  
Housing: metal, IP67



pin socket assignment ccw



suitable for our series:

5850 / 5870  
5852 / 5872

*Terminal assignment*





Pin female contacts:	1	2	3	4	5	6	7	8	9	10	11	12	13	14	15	16	17
Wire colour:	WH	BN	GN	YE	GY	PK	BU	RD	BK	VT	GY-PK	RD-BU	WH-GN	BN-GN	WH-YE	YE-BN	WH-GY

*Cable length <sup>1)</sup>*

2 m [6.56']	<b>8.0000.6741.0002</b>
5 m [16.40']	<b>8.0000.6741.0005</b>
10 m [32.81']	<b>8.0000.6741.0010</b>
15 m [49.21']	<b>8.0000.6741.0015</b>

1) Other cable lengths on request.

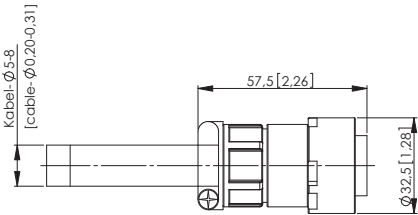
# Connection technology

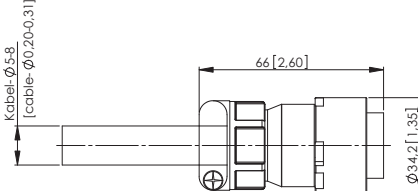
MIL connection technology		Connectors, self-assembly		Order no.
<b>7 pin</b>				
<b>Female connector with coupling nut</b>  Housing: metal, IP67	solder connections, for cable $\varnothing$ 5 ... 8 mm [0.20 ... 0.32"]	suitable for our series:  5803 / 5823		<b>8.0000.5052.0000</b>
	 			
<b>10 pin</b>				
<b>Female connector with coupling nut</b>  Housing: metal, IP67	solder connections, for cable $\varnothing$ 5 ... 8 mm [0.20 ... 0.32"]	suitable for our series:  5000 / 5020    5803 / 5823 A02H            LM3		<b>8.0000.5062.0000</b>
	 			

## RJ45 connection technology Connectors, self-assembly

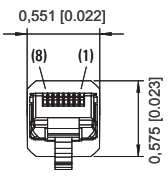
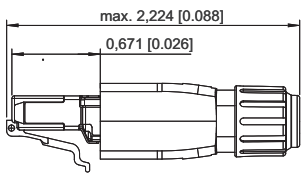
8 pin			Order no.
<b>RJ45 connector straight</b> Housing: plastic, IP20	screw connections, for cable $\varnothing$ 4.5 ... 8 mm [0.18 ... 0.32"]	suitable for:  BMB1, BMC1, SMBU, SMBS, SMBD	<b>05.VS-08-RJ45-5-Q/IP20</b>
			

# Connection technology

## RJ45 connection technology | Cordsets, pre-assembled

With RJ45 and Mini-IO connector, 8 pin Working temp. -20°C ... +60°C [-4°F ... +140°F] Order no.

### RJ45 connector + Mini-IO connector

Cable: PVC, 6 x 2 x 0.14 mm<sup>2</sup> [AWG 25]  
 Housing: ABS, metallised

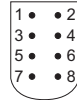

suitable for our series:

EMAI  
 SMAS

### Terminal assignment

Signal:	0 V	+V	B	$\bar{B}$	A	$\bar{A}$	$\perp$
Pin Mini-I/O:	8	n.c.	5	6	2	1	PH <sup>2)</sup>
Pin RJ45:	2	1	4	5	7	8	PH <sup>2)</sup>

Cable length<sup>1)</sup>

**Terminal ENC1, ENC2**  
 HTL, SinCos

1 m [3.28']



**8.SMAS.C21.001M**

- +V: encoder power supply +V DC
- 0 V: encoder power supply ground GND (0 V)
- A,  $\bar{A}$ : cosine signal, incremental signal A
- B,  $\bar{B}$ : sine signal, incremental signal B
- PH  $\perp$ : plug connector housing (shield)

1) Other cable lengths on request.  
 2) Shield on housing.

# Connection technology

## RJ45 connection technology Cordsets, pre-assembled

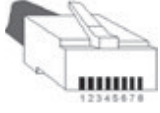
Ethernet patch cable with 2 x RJ45 connector		Working temp. -20°C ... +60°C [-4°F ... +140°F]	Order no.
<b>Ethernet adapter cable</b>		suitable for our series:	
<p>Cable: PVC, orange category 6A acc. to EN 50173-1 6 x 2 x 0.14 mm<sup>2</sup> [AWG 25], shielded twisted pairs</p> <p>Housing: ABS, metallised</p>  	<p>EMAA SMAS</p>		
		<i>Cable length <sup>1)</sup></i>	
	Terminal ENC1, ENC2	0.25 m [0.82']	<b>8.SMAS.C22.0M25</b>
	SinCos, SSI	0.5 m [1.64']	<b>8.SMAS.C22.0M50</b>
		1 m [3.28']	<b>8.SMAS.C22.001M</b>
<b>Ethernet patch cable</b>		suitable for our series:	
<p>Cable: PUR, grey/white 4 x 2 x 0.15 mm<sup>2</sup> [AWG 25], shielded</p> <p>Housing: ABS, metallised</p>  	<p>SMBD.32E SMBU SMBS BMB1 BMC1</p>		
		<i>Cable length <sup>1)</sup></i>	
	Terminal Ethernet	2 m [6.56']	<b>05.00.60A1.7272.002M</b>
	Parameterizing interface	5 m [16.40']	<b>05.00.60A1.7272.005M</b>
		10 m [32.81']	<b>05.00.60A1.7272.010M</b>
		15 m [49.21']	<b>05.00.60A1.7272.015M</b>

1) Other cable lengths on request.  
2) Shield on housing.

# Connection technology

## Sub-D connection technology Connectors, self-assembly

9 pin			Order no.
<p><b>Male connector with cable outlet 70°</b></p> <p>Housing: ABS, metallised, IP20</p>	<p>solder contacts, for cable <math>\varnothing</math> 3.5 ... 8.6 mm [0.14 ... 0.34"]</p>	<p>suitable for our series:</p> <p>SMC1 MS1, MSP1, MS2, MSP2 BM21, BM31</p>	<p><b>8.0000.514A.0000</b></p>
<p><b>Female connector with cable outlet 70°</b></p> <p>Housing: ABS, metallised, IP20</p>	<p>solder contacts, for cable <math>\varnothing</math> 3.5 ... 8.6 mm [0.14 ... 0.34"]</p>	<p>suitable for our series:</p> <p>SMC1</p>	<p><b>8.0000.514B.0000</b></p>

Connection technology

# Connection technology

## Sub-D connection technology Cordsets, pre-assembled

### With Sub-D connector

Working temp. -30°C ... +80°C [-22°F ... +176°F]

Order no.

#### Sub-D female connector, 9-pin with cable outlet 70° + single-ended

Cable: PVC, 3 x 2 x 0.25 mm<sup>2</sup> [AWG 23]  
Housing: ABS, metallised, IP20

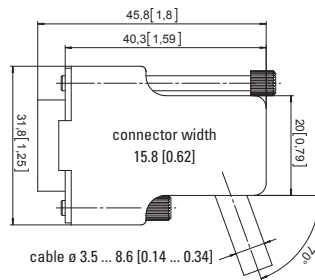
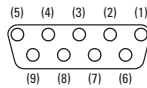

suitable for our series:

SMC1

#### Terminal assignment

Signal:	0 V	+V	A	$\bar{A}$	B	$\bar{B}$	$\perp$
Pin Sub-D:	5	4	1	9	3	2	PH <sup>1)</sup>
Wire colour:	WH	BR	GN	YE	GY	PK	

Terminal X6, X7  
for SinCos signals

#### Cable length <sup>1)</sup>

2 m [6.56']	<b>8.0000.6V00.0002.0086</b>
5 m [16.40']	<b>8.0000.6V00.0005.0086</b>
10 m [32.81']	<b>8.0000.6V00.0010.0086</b>
15 m [49.21']	<b>8.0000.6V00.0015.0086</b>

#### Sub-D male connector, 9-pin with cable outlet 70° + single-ended

Cable: PVC, 3 x 2 x 0.25 mm<sup>2</sup> [AWG 23]  
Housing: ABS, metallised, IP20

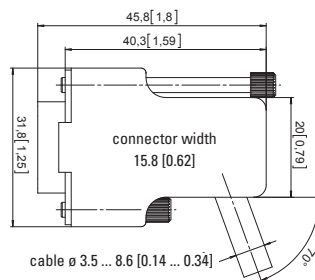
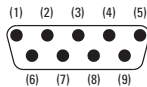

suitable for our series:

SMC1

#### Terminal assignment

Signal:	0 V	+V	A	$\bar{A}$	B	$\bar{B}$	$\perp$
Pin Sub-D:	5	4	1	9	3	2	PH <sup>1)</sup>
Wire colour:	WH	BR	GN	YE	GY	PK	

Terminal X5  
for SinCos signals

#### Cable length <sup>1)</sup>

2 m [6.56']	<b>8.0000.6V00.0002.0087</b>
5 m [16.40']	<b>8.0000.6V00.0005.0087</b>
10 m [32.81']	<b>8.0000.6V00.0010.0087</b>
15 m [49.21']	<b>8.0000.6V00.0015.0087</b>

- +V: encoder power supply +V DC
- 0 V: encoder power supply ground GND (0 V)
- C+, C-: clock signal
- D+, D-: data signal
- A,  $\bar{A}$ : cosine signal
- B,  $\bar{B}$ : sine signal
- PH  $\perp$ : plug connector housing (shield)

1) Other cable lengths on request.  
2) Shield on housing.



# Connection technology

## Sub-D connection technology Cordsets, pre-assembled

With Sub-D connector Working temp. -30°C ... +80°C [-22°F ... +176°F] Order no.

### Sub-D male connector, 9-pin with cable outlet 70° + single-ended

Cable: PVC, 6 x 2 x 0.14 mm<sup>2</sup> [AWG 25]  
Housing: ABS, metallised, IP20

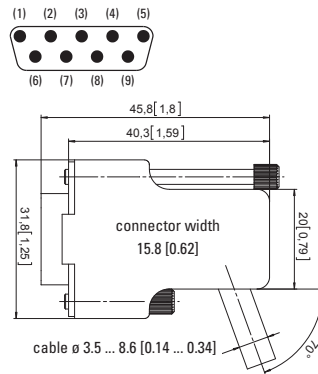

suitable for our series:

MS1, MSP1, MS2, MSP2

#### Terminal assignment

Signal:	0 V	+V	A	$\bar{A}$	B	$\bar{B}$	$\perp$
Pin Sub-D:	2	9	8	4	5	6	PH <sup>2)</sup>
Wire colour:	WH	BR	BK	VT	GY/PK	RD/BU	

Signal:	0 V	+V	C+	C-	D+	D-	$\perp$
Pin Sub-D:	2	9	8	4	5	6	PH <sup>2)</sup>
Wire colour:	WH	BR	GN	YE	GY	PK	

Signal:	0 V	+V	C+	C-	D+	D-	$\perp$
Pin Sub-D:	2	9	3	7	5	6	PH <sup>2)</sup>
Wire colour:	WH	BR	GN	YE	GY	PK	

Cable: PVC, 3 x 2 x 0.25 mm<sup>2</sup> [AWG 23]  
Housing: ABS, metallised, IP20

Signal:	0 V	+V	A	$\bar{A}$	B	$\bar{B}$	$\perp$
Pin Sub-D:	2	9	8	4	5	6	PH <sup>2)</sup>
Wire colour:	WH	BR	GN	YE	GY	PK	

#### Cable length <sup>1)</sup>

<b>Terminal X31, X32, X33, X34</b>	2 m [6.56']	<b>8.0000.6900.0002.0076</b>
for SinCos signals + TTL	5 m [16.40']	<b>8.0000.6900.0005.0076</b>
(for absolute encoders)	10 m [32.81']	<b>8.0000.6900.0010.0076</b>
	15 m [49.21']	<b>8.0000.6900.0015.0076</b>

<b>Terminal X31, X32</b>	2 m [6.56']	<b>8.0000.6900.0002.0075</b>
for SSI signals	5 m [16.40']	<b>8.0000.6900.0005.0075</b>
(for absolute encoders)	10 m [32.81']	<b>8.0000.6900.0010.0075</b>
	15 m [49.21']	<b>8.0000.6900.0015.0075</b>

<b>Terminal X33, X34</b>	2 m [6.56']	<b>8.0000.6900.0002.0078</b>
for SSI signals	5 m [16.40']	<b>8.0000.6900.0005.0078</b>
(for absolute encoders)	10 m [32.81']	<b>8.0000.6900.0010.0078</b>
	15 m [49.21']	<b>8.0000.6900.0015.0078</b>

<b>Terminal X31, X32, X33, X34</b>	2 m [6.56']	<b>8.0000.6V00.0002.0082</b>
for SinCos signals	5 m [16.40']	<b>8.0000.6V00.0005.0082</b>
(for incremental encoders)	10 m [32.81']	<b>8.0000.6V00.0010.0082</b>
	15 m [49.21']	<b>8.0000.6V00.0015.0082</b>

- +V: encoder power supply +V DC
- 0 V: encoder power supply ground GND (0 V)
- C+, C-: clock signal
- D+, D-: data signal
- A,  $\bar{A}$ : cosine signal, incremental signal A
- B,  $\bar{B}$ : sine signal, incremental signal B
- PH  $\perp$ : plug connector housing (shield)

1) Other cable lengths on request.  
2) Shield on housing.

## Sub-D connection technology Cordsets, pre-assembled

### With Sub-D connector

Working temp. -30°C ... +80°C [-22°F ... +176°F]

Order no.

#### 2 x Sub-D male connector, 9-pin with cable outlet 70° + single-ended

Cable: PVC, 6 x 2 x 0.14 mm<sup>2</sup> [AWG 25]  
Housing: ABS, metallised, IP20

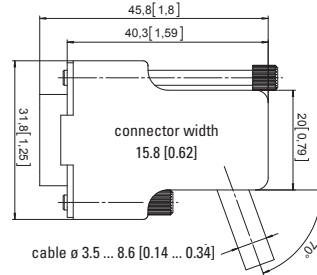
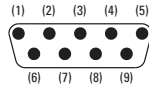

suitable for our series:

MSP1, MSP2

#### Terminal assignment

Cable length <sup>1)</sup>

Signal:	0 V	+V	C+	C-	D+	D-	A	$\bar{A}$	B	$\bar{B}$	$\perp$
Pin Sub-D 1:	2	9	3	7	5	6	-	-	-	-	PH <sup>2)</sup>
Pin Sub-D 2:	-	-	-	-	-	-	8	4	5	6	PH <sup>2)</sup>
Wire colour:	WH	BR	GN	YE	GY	PK	BK	VT	GY/PK	RD/BU	

#### Terminal X31/X33, X32/X34

for SSI signals and  
SinCos signals + TTL

2 m [6.56']
5 m [16.40']
10 m [32.81']
15 m [49.21']

<b>8.0000.6900.0002.0077</b>
<b>8.0000.6900.0005.0077</b>
<b>8.0000.6900.0010.0077</b>
<b>8.0000.6900.0015.0077</b>

- +V: encoder power supply +V DC
- 0 V: encoder power supply ground GND (0 V)
- C+, C-: clock signal
- D+, D-: data signal
- A,  $\bar{A}$ : cosine signal, incremental signal A
- B,  $\bar{B}$ : sine signal, incremental signal B
- PH  $\perp$ : plug connector housing (shield)

1) Other cable lengths on request.  
2) Shield on housing.

# Connection technology

## Sub-D connection technology Cordsets, pre-assembled

With Sub-D connector + M12 connector Working temp. -30°C ... +80°C [-22°F ... +176°F] Order no.

**Sub-D male connector, 9 pin, cable outlet 70° + M12 female connector with coupling nut, 8 pin, A coded**

Cable: PVC, 3 x 2 x 0.25 mm<sup>2</sup> [AWG 23]  
 Housing Sub-D: ABS, metallised, IP20  
 Housing M12: metal / plastic, IP67

suitable for our series:

5000 / 5020    5006 / 5026  
 5814 / 5834    5814FSx / 5834FSx  
 5821  
 SMC1

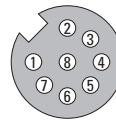
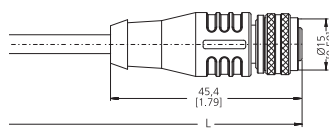
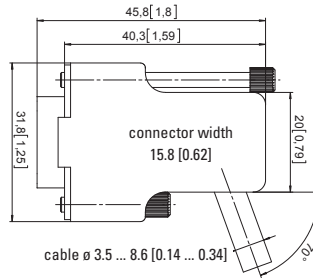

### Terminal assignment

Pin Sub-D:	5	4	1	9	3	2	PH <sup>2)</sup>
Pin M12:	1	2	3	4	5	6	PH <sup>2)</sup>
pins arranged below each other are connected internally							

for terminal X6, X7 at SMC1

### Cable length <sup>1)</sup>

2 m [6.56']	<b>8.0000.6V00.0002.0084</b>
5 m [16.40']	<b>8.0000.6V00.0005.0084</b>
10 m [32.81']	<b>8.0000.6V00.0010.0084</b>
15 m [49.21']	<b>8.0000.6V00.0015.0084</b>

1) Other cable lengths on request.  
 2) Shield on housing.

# Connection technology

## Sub-D connection technology Cordsets, pre-assembled

With Sub-D connector + M23 connector

Working temp. -30°C ... +80°C [-22°F ... +176°F]

Order no.

**Sub-D female connector, 9-pin, cable outlet 70°  
+ M23 female connector with coupling nut,  
12 pin**

Cable: PVC, 3 x 2 x 0.25 mm<sup>2</sup> [AWG 23]  
Housing Sub-D: ABS, metallised, IP20  
Housing M23: metal, IP67

suitable for our series:

5000 / 5020    5006 / 5026  
5814 / 5834    5814FSx / 5834FSx  
5821  
SMC1

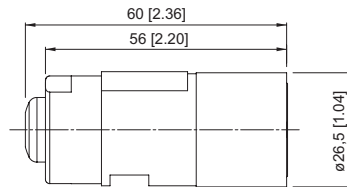
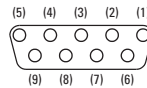
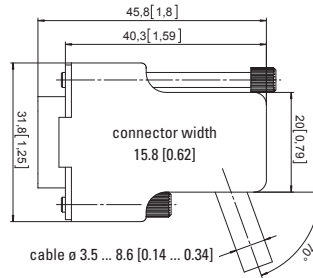

pin socket  
assignment cw

### Terminal assignment

Pin Sub-D:	5	4	1	9	3	2	PH <sup>2)</sup>
Pin M23:	10	12	5	6	8	1	PH <sup>2)</sup>
pins arranged below each other are connected internally							

for terminal X6, X7  
at SMC1

### Cable length<sup>1)</sup>

2 m [6.56']  
5 m [16.40']  
10 m [32.81']  
15 m [49.21']

**8.0000.6V00.0002.0085**  
**8.0000.6V00.0005.0085**  
**8.0000.6V00.0010.0085**  
**8.0000.6V00.0015.0085**

1) Other cable lengths on request.  
2) Shield on housing.

# Connection technology

## Sub-D connection technology Cordsets, pre-assembled

With Sub-D connector + M23 connector Working temp. -30°C ... +80°C [-22°F ... +176°F] Order no.

**Sub-D male connector, 9-pin, cable outlet 70°  
+ M23 female connector with coupling nut,  
12 pin**

Cable: PVC, 3 x 2 x 0.25 mm<sup>2</sup> [AWG 23]  
Housing Sub-D: ABS, metallised, IP20  
Housing M23: metal, IP67

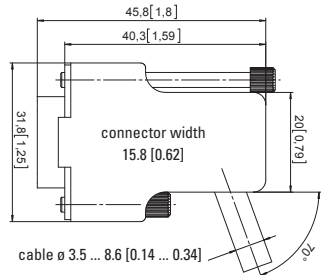

suitable for our series:

5000 / 5020    5006 / 5026  
5814 / 5834    5814FSx / 5834FSx  
5821

MS1, MSP1, MS2, MSP2

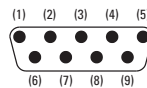

### Terminal assignment

Pin Sub-D:	2	9	8	4	5	6	PH <sup>2)</sup>
Pin M23:	1	2	9	10	11	12	PH <sup>2)</sup>
pins arranged below each other are connected internally							

### Cable length <sup>1)</sup>

for terminal X31, X32, X33, X34	2 m [6.56']
at MS1, MSP1, MS2, MSP2	5 m [16.40']
	10 m [32.81']
	15 m [49.21']

<b>8.0000.6V00.0002.0081</b>
<b>8.0000.6V00.0005.0081</b>
<b>8.0000.6V00.0010.0081</b>
<b>8.0000.6V00.0015.0081</b>

1) Other cable lengths on request.  
2) Shield on housing.

# Connection technology

## Sub-D connection technology Cordsets, pre-assembled

With Sub-D connector + M23 connector

Working temp. -30°C ... +80°C [-22°F ... +176°F]

Order no.

**Sub-D male connector, 9-pin, cable outlet 70° + M23 female connector with coupling nut, 12 pin**

Cable: PVC, 6 x 2 x 0.14 mm<sup>2</sup> [AWG25]  
 Housing Sub-D: ABS, metallised, IP20  
 Housing M23: metal, IP67

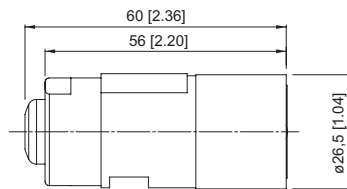
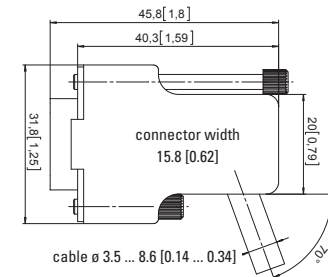

suitable for our series:

5853 / 5873 5853FSx / 5873FSx  
 5863 / 5883 5863FSx / 5883FSx  
 F5863 / F5883

MS1, MSP1, MS2, MSP2

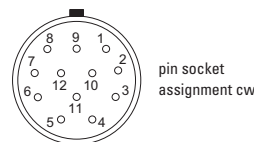
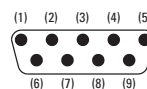

### Terminal assignment

Pin Sub-D:	2	9	8	4	5	6	PH <sup>2)</sup>
Pin M23:	1	2	3	4	5	6	PH <sup>2)</sup>
pins arranged below each other are connected internally							

Pin Sub-D:	2	9	3	7	5	6	PH <sup>2)</sup>
Pin M23:	1	2	3	4	5	6	PH <sup>2)</sup>
pins arranged below each other are connected internally							

### Cable length<sup>1)</sup>

for terminal X31, X32 at MS1, MSP1, MS2, MSP2	2 m [6.56']	<b>8.0000.6900.0002.0068</b>
	5 m [16.40']	<b>8.0000.6900.0005.0068</b>
	10 m [32.81']	<b>8.0000.6900.0010.0068</b>
	15 m [49.21']	<b>8.0000.6900.0015.0068</b>
for terminal X33, X34 at MSP1, MSP2	2 m [6.56']	<b>8.0000.6900.0002.0072</b>
	5 m [16.40']	<b>8.0000.6900.0005.0072</b>
	10 m [32.81']	<b>8.0000.6900.0010.0072</b>
	15 m [49.21']	<b>8.0000.6900.0015.0072</b>

1) Other cable lengths on request.  
 2) Shield on housing.

# Connection technology

## Sub-D connection technology Cordsets, pre-assembled

With Sub-D connector + M23 connector Working temp. -30°C ... +80°C [-22°F ... +176°F] Order no.

**2 x Sub-D male connector, 9-pin, cable outlet 70° + M23 female connector with coupling nut, 12 pin**

Cable: PVC, 6 x 2 x 0.14 mm<sup>2</sup> [AWG25]  
 Housing Sub-D: ABS, metallised, IP20  
 Housing M23: metal, IP67

suitable for our series:

5853 / 5873    5853FSx / 5873FSx  
 5863 / 5883    5863FSx / 5883FSx  
 MSP1, MSP2

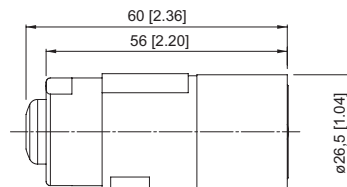
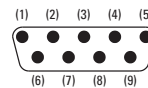
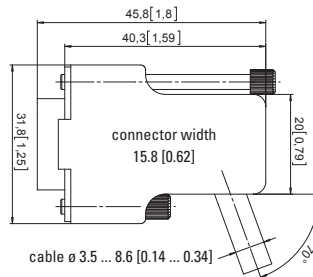

pin socket assignment cw

### Terminal assignment

Pin Sub-D 1:	2	9	3	7	5	6	-	-	-	-	PH <sup>2)</sup>
Pin Sub-D 2:	-	-	-	-	-	-	8	4	5	6	PH <sup>2)</sup>
Pin M23:	1	2	3	4	5	6	9	10	11	12	PH <sup>2)</sup>
pins arranged below each other are connected internally											

for terminal X31/X33, X32/X34 at MSP1, MSP2

### Cable length<sup>1)</sup>

2 m [6.56']  
 5 m [16.40']  
 10 m [32.81']  
 15 m [49.21']

**8.0000.6900.0002.0070**  
**8.0000.6900.0005.0070**  
**8.0000.6900.0010.0070**  
**8.0000.6900.0015.0070**

1) Other cable lengths on request.  
 2) Shield on housing.

# Connection technology

## Sub-D connection technology Cordsets, pre-assembled

With Sub-D connector + M23 connector

Working temp. -30°C ... +80°C [-22°F ... +176°F]

Order no.

**2 x Sub-D male connector, 9-pin with SET and DIR, cable outlet 70° + M23 female connector with coupling nut, 12 pin**

Cable: PVC, 6 x 2 x 0.14 mm<sup>2</sup> [AWG25]  
 Housing Sub-D: ABS, metallised, IP20  
 Housing M23: metal, IP67

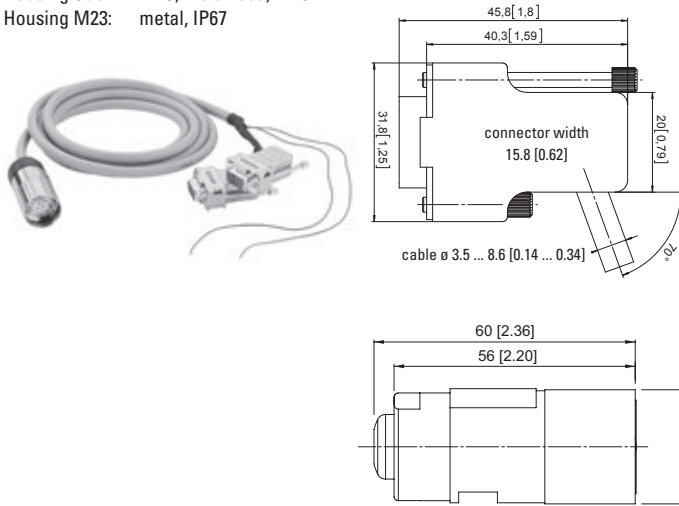

suitable for our series:

5853 / 5873    5853FSx / 5873FSx  
 5863 / 5883    5863FSx / 5883FSx

MSP1, MSP2

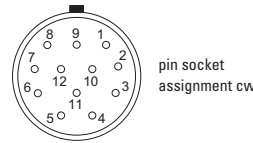
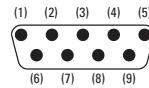

### Terminal assignment

Pin Sub-D 1:	2	9	3	7	5	6	-	-	-	-	-	PH <sup>2)</sup>	
Pin Sub-D 2:	-	-	-	-	-	-	-	8	4	5	6	PH <sup>2)</sup>	
Pin M23:	1	2	3	4	5	6	7	8	9	10	11	12	PH <sup>2)</sup>
Wire colour:							BU SET	RD DIR					
pins arranged below each other are connected internally													

### Cable length<sup>1)</sup>

for terminal  
 X31/X33, X32/X34  
 at MSP1, MSP2

2 m [6.56']  
 5 m [16.40']  
 10 m [32.81']  
 15 m [49.21']

**8.0000.6900.0002.0080**  
**8.0000.6900.0005.0080**  
**8.0000.6900.0010.0080**  
**8.0000.6900.0015.0080**

1) Other cable lengths on request.  
 2) Shield on housing.



# Connection technology

## Sub-D connection technology Cordsets, pre-assembled

**With Sub-D connector** Working temp. -30°C ... +80°C [-22°F ... +176°F] Order no.

**Sub-D female connector, cable outlet 90° + single-ended**  
**Profibus master with terminating resistor**

Cable: PUR, 2 x 0.34 mm<sup>2</sup> [AWG22]  
 Housing: metal / plastic

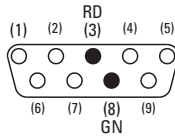

suitable for our series:

5858 / 5878  
 5868 / 5888  
 9080  
 BM31



*Terminal assignment*

Pin Sub-D:	1	2	3	4	5	6	7	8	9	PH <sup>2)</sup>
Wire colour:	-	-	RD	-	-	-	-	GN	-	

*Cable length <sup>1)</sup>*

2 m [6.56']	<b>05.00.6011.5511.002M</b>
5 m [16.40']	<b>05.00.6011.5511.005M</b>
10 m [32.81']	<b>05.00.6011.5511.010M</b>
15 m [49.21']	<b>05.00.6011.5511.015M</b>

1) Other cable lengths on request.  
 2) Shield on housing.

# Connection technology

## Sub-D connection technology Cordsets, pre-assembled

**With Sub-D connector + M12 connector** Working temp. -30°C ... +80°C [-22°F ... +176°F] Order no.

**Sub-D male connector, 9 pin, cable outlet 90°** Bus in  
**Profibus master with terminating resistor + M12 female connector with coupling nut, 5 pin, B coded**

Cable: PUR, 2 x 0.34 mm<sup>2</sup> [AWG22]  
 Housing Sub-D: ABS, metallised  
 Housing M12: metal / plastic

suitable for our series:

5858 / 5878  
 5868 / 5888  
 9080

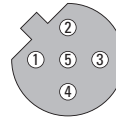
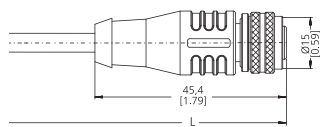
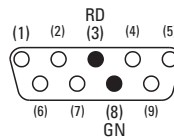

**Terminal assignment**

Pin Sub-D:		3		8		PH <sup>2)</sup>
Pin M12:	1	2	3	4	5	PH <sup>2)</sup>
pins arranged below each other are connected internally						

**Cable length<sup>1)</sup>**

2 m [6.56']  
 5 m [16.40']  
 10 m [32.81']  
 15 m [49.21']

**05.00.6011.5532.002M**  
**05.00.6011.5532.005M**  
**05.00.6011.5532.010M**  
**05.00.6011.5532.015M**

**Sub-D male connector, 9 pin, cable outlet 90°** Bus out  
**Profibus master with terminating resistor + M12 male connector with external thread, 5 pin, B coded**

Cable: PUR, 2 x 0.34 mm<sup>2</sup> [AWG22]  
 Housing Sub-D: ABS, metallised  
 Housing M12: metal / plastic

suitable for our series:

5858 / 5878  
 5868 / 5888  
 9080

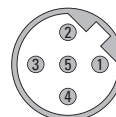
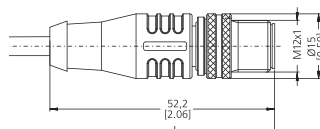
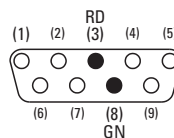

**Terminal assignment**

Pin Sub-D:		8		3		PH <sup>2)</sup>
Pin M12:	1	2	3	4	5	PH <sup>2)</sup>
pins arranged below each other are connected internally						

**Cable length<sup>1)</sup>**

2 m [6.56']  
 5 m [16.40']  
 10 m [32.81']  
 15 m [49.21']

**05.00.6011.5534.002M**  
**05.00.6011.5534.005M**  
**05.00.6011.5534.010M**  
**05.00.6011.5534.015M**

1) Other cable lengths on request.  
 2) Shield on housing.

# Connection technology

## Sub-D connection technology Cordsets, pre-assembled

**With Sub-D connector + M12 connector** Working temp. -30°C ... +80°C [-22°F ... +176°F] Order no.

**Sub-D male connector, 9 pin, cable outlet 90°  
Profibus master with terminating resistor +  
M12 male connector with external thread and  
M12 female connector with coupling nut,  
5 pin, B coded**

Bus in, Bus out

suitable for our series:

Cable: PUR, 2 x 0.34 mm<sup>2</sup> [AWG22]  
Housing Sub-D: ABS, metallised  
Housing M12: metal / plastic

5858 / 5878  
5868 / 5888  
9080

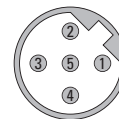
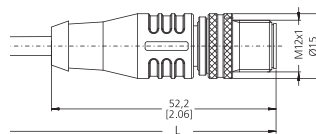
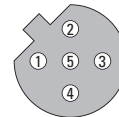
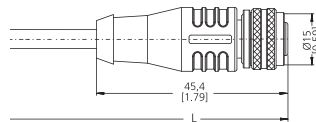
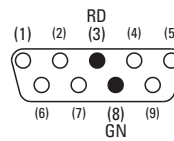

### Terminal assignment

Pin Sub-D:		8		3		PH <sup>2)</sup>
Pin M12 female contacts:	1	2	3	4	5	PH <sup>2)</sup>
Pin M12 male contacts:	1	2	3	4	5	PH <sup>2)</sup>
pins arranged below each other are connected internally						

### Cable length<sup>1)</sup>

2 x 2 m [6.56']	<b>05.00.6012.5536.002M</b>
2 x 5 m [16.40']	<b>05.00.6012.5536.005M</b>
2 x 10 m [32.81']	<b>05.00.6012.5536.010M</b>
2 x 15 m [49.21']	<b>05.00.6012.5536.015M</b>

Connection technology

1) Other cable lengths on request.  
2) Shield on housing.



# Addresses

	Page
<b>Kübler worldwide</b>	<b>84</b>
<b>Contact partners in Germany</b>	<b>86</b>



# Kübler worldwide

## Kübler Group

**Fritz Kübler GmbH, Germany**  
Schubertstraße 47  
D-78054  
Villingen-Schwenningen  
Phone +49 7720 39 03-0  
Fax +49 7720 21 56 4  
info@kuebler.com  
www.kuebler.com

**Fritz Kübler SARL, France**  
2 rue de Grande Bretagne  
F-68310 Wittelsheim  
Phone +33 3 89 53 45 45  
Fax +33 3 89 53 66 77  
info@kuebler-sarl.com  
www.kuebler.fr

**Kübler Italia S.r.l., Italy**  
Viale Sarca, 96  
I-20125 Milano MI  
Phone +39 026 423 345  
Fax +39 026 611 3843  
info@kuebler.it  
www.kuebler.it

**Kubler SP. Z O.O., Poland**  
I. Dabrowskiego 441  
PL-60-451 Poznan  
Phone +48 61 84 99 902  
Fax +48 61 84 99 903  
info@kubler.pl  
www.kubler.pl

**Kübler Turkey Otomasyon Ticaret Ltd. Sti. Turkey**  
Yeni mahalle Balikesir Cad.  
Uprise Elit Residence C1 AB Blok  
No:180 Soganklik  
TR - 34880 Kartal/Istanbul  
Phone: +90 216 999 9791  
Fax: +90 216 999 9784  
cengizhan.temurcin@kuebler.com  
www.kuebler.com

**Kuebler (Beijing) Automation Trading Co. Ltd., China**  
Rm 1603, B Area, Tower 2,  
Wangjing Soho,  
No.1 Futong East Street,  
Chaoyang, Beijing, China,100102  
Phone +86 10 8471 0818  
Fax: +86 10 8471 0819  
beijing@kuebler.com  
www.kuebler.com

**Kuebler Automation India Pvt. Ltd. India**  
Plot No 677, S.No. 269/3,  
Paud Road, Bhugaon,  
Pune 412 115,  
Maharashtra  
Phone +91 99 7065 5599  
Tel. +91 20 6790 1-200/230/  
214/202  
Fax +91 20 6790 1232  
info@kuebler.in  
www.kuebler.in

**Kuebler Korea (by F&B), South Korea**  
578, Kwaebop-dong, Sasang-ku  
Pusan Industrial Supplies  
Market 9-116  
ROK-PUSAN  
Phone +82 51 319 12 30  
Fax +82 51 319 12 50  
fnb@kuebler.co.kr  
www.kuebler.kr

**Kuebler Inc. USA**  
5245-3 Old Dowd Road  
Charlotte, NC 28208  
Phone +1-704-705-4711  
Toll Free +1-855-KUEBLER (583-2537)  
Fax +1-704-733-9170  
usa@kuebler.com  
www.kuebler.com/usa

## Europe

**Austria**  
Balluff GmbH  
Industriestraße B16  
A-2345 Brunn am Gebirge  
Phone +43 22 36 3 25 21-0  
Fax +43 22 36 3 25 21 46  
sensor@balluff.at  
www.balluff.at

**Belarus**  
FEK Company  
Pushkin Ave., 29B  
BY-220015 Minsk  
Phone +375 17 202 68 00  
Fax +375 17 202 68 01  
turck@fek.by  
www.turck.by

**Belgium**  
Multiprox N.V.  
Lion d'Orweg 12  
B-9300 Aalst  
Phone +32 53 76 65 66  
Fax +32 53 78 39 77  
mail@multiprox.be  
www.multiprox.be

**Bulgaria**  
Sensomat Ltd.  
UL.Stratsin 4, vh.A, app.1  
P.O.B. 116  
BG-9300-Dobrich  
Phone +359-888 403 570  
Fax +359-58-603 033  
info@sensomat.info  
www.sensomat.info

**Croatia**  
Bering d.o.o.  
Naselje Tršinski 7b  
HR-49210 Zabok  
Phone +385 49 221 182  
Fax +385 49 223 658  
bering@email-t.com.hr  
www.bering.hr

**Czech Republic**  
TURCK s.r.o  
Hradecká 1151  
CZ-500 03 Hradec Králové  
Phone +420 - 4 95 51 87 66  
Fax +420 - 4 95 51 87 67  
turck-cz@turck.com  
www.turck.cz

**Denmark**  
Hans Folsgaard A/S  
Theilgaard's Torv 1  
DK-4600 Køge  
Phone + 45 43 20 86 00  
Fax + 45 43 96 88 55  
hf@hf.net  
www.hf.net

**Estonia**  
Standel AS  
Kiisa 8  
EE-11313 Tallinn  
Phone +372 6 558 180  
Fax +372 6 558 179  
standel@standel.ee  
www.standel.ee

**Finland**  
Sähkölehto Oy  
Holkitie 14  
FIN-00880 Helsinki  
Phone +358 9 774 6420  
Fax +358 9 759 1071  
office@sahkolehto.fi  
www.sahkolehto.fi

**France**  
Fritz Kübler S.à.r.l.  
Compteurs et codeurs  
industriels  
2 rue de Grande Bretagne  
F-68310 Wittelsheim  
Phone +33 3 89 53 45 45  
Fax +33 3 89 53 66 77  
info@kuebler-sarl.com  
www.kuebler.fr

**Great Britain**  
OEM Automatic Ltd  
Whiteacres, Cambridge Road  
Whetstone  
GB-Leicester LE8 6ZG  
Phone +44 116 284 99 00  
Fax +44 116 284 17 21  
information@uk.oem.se  
www.oem.co.uk

**Greece**  
Industrial Automation  
Systems  
L.J. Skourgialos  
241, El. Venizelou Ave.  
GR-176 73 Kallithea - Athens  
Phone +30 210 9510260  
Fax +30 210 9511048  
info@ias.gr  
www.ias.gr

**Hungary**  
Kvalix Automatika Kft.  
Kiss Ernő u. 1-3  
H-1046 Budapest  
Phone +36 1 272 2242  
Fax +36 1 272 2244  
info@kvalix.hu  
www.kvalix.hu

**Iceland**  
Reykjafell Ltd.  
Skipholt 35  
IS-125 Reykjavik  
Phone +354 5 88 60 00  
Fax +354 5 88 60 88  
reykjafell@reykjafell.is  
www.reykjafell.is

**Ireland**  
Kübler Group  
Fritz Kübler GmbH  
Schubertstr. 47  
D-78054  
Villingen-Schwenningen  
Phone +49 7720 3903-0  
Fax +49 7720 21564  
info@kuebler.com  
www.kuebler.com

**Italy**  
• Encoders:  
Kübler Italia Srl.  
Viale Sarca, 96  
I-20125 Milano MI  
Phone +39 026 423 345  
Fax +39 026 611 3843  
info@kuebler.it  
www.kuebler.it

• Counters and process  
devices:  
MAS AUTOMAZIONE S.R.L.  
Via G. Galilei 20  
I-20090 Segrate (MI)  
Phone +39 02 26 92 20 90  
Fax +39 02 26 92 16 87  
info@masautomazione.it  
www.masautomazione.it

**Lithuania**  
UAB FEK Elektronika  
Naugarduko 91-415  
LT-03160, Vilnius, Lietuva  
Phone +370 700 01760  
Phone +3705 2133603  
Fax +3705 2159198  
info@fek.lt  
www.fek.lt

**Netherlands**  
Duranmatic B.V.  
Robijn 800  
NL-3316 KE Dordrecht  
Phone +31 78 631 05 99  
Fax +31 78 613 11 33  
info@duranmatic.nl  
www.duranmatic.nl

**Norway**  
ELTECO AS  
Floodmyrveien 24  
N-3946 Porsgrunn  
Phone +47 35 56 20 70  
Fax +47 35 56 20 99  
firmapost@eltenco.no  
www.eltenco.no

**Poland**  
Kubler Sp. z o.o.  
ul. Dabrowskiego 441  
PL-60-451 Poznan  
Phone +48 61 849 99 02  
Fax +48 61 849 99 03  
info@kubler.pl  
www.kubler.pl

ASTAT sp. z o.o.  
ul. Dabrowskiego 441  
PL-60-451 Poznan  
Phone +48 61 848 8276  
Fax +48 61 848 8276  
info@astat.com.pl  
www.astat.com.pl

• Electronic counters and  
process displays:  
IMPOL-1 Sp.J.  
ul. Krakowiaków 103  
PL-02-255 Warszawa  
Phone +48 22 886 56 02  
Fax +48 22 886 56 04  
biuro@impol-1.pl  
www.impol-1.pl

• Encoders:  
OEM AUTOMATIC Sp. z o.o.  
ul. Działkowa 121 A  
PL-02-234 Warszawa  
Phone +48 22 863 27 22  
Fax +48 22 863 27 24  
info@pl.oem.se  
www.oemautomatic.pl

**Portugal**  
LA2P – Tecnologias de  
Automação, LDA  
Rua Teófilo Braga, 156 A  
Escrit. F - Edifício S. Domingos  
Cabeço do Mouro  
PT-2785- 122 S. Domingos  
de Rana  
Phone +351 21 444 70 70  
Fax +351 21 444 70 75  
la2p@la2p.pt  
www.la2p.pt

**Romania**  
Syscom 18 SRL  
Calea Plevnei 139B, Sector 6  
RO-060011 Bucharest  
Phone +40 21 310 26 78  
Fax +40 21 316 91 76  
syscom@syscom.ro  
www.syscom.ro

**Russia**  
Servotechnica ZAO  
Klara Tsetkin str., 33/35  
RUS-125130 Moscow  
Phone +7 495 797 8866  
Fax +7 495 450 0043  
info@servotechnica.ru  
www.servotechnica.ru

**Sweden**  
OEM AUTOMATIC AB  
Dalagatan 4, Box 1011  
S-57328 Tranås  
Phone +46 75-242 4100  
Fax +46 75-242 4119  
info@aut.oem.se  
www.oemautomatic.se

**Serbia**  
RAP Electronics d.o.o.  
Dorda Stanojevic 11-17  
SRB-11070 Novi Beograd  
Phone +381 11 6300636  
Fax +381 11 6300635  
office@rapelectronics.co.rs

**Slovakia**  
S.D.A. s. r. o.  
Jána Bottu 4  
SK-974 01 Banská Bystrica  
Phone +421 48 472 34 11  
Fax +421 48 472 343 69  
sekretariat@s-d-a.sk  
www.s-d-a.sk

**Slovenia**  
Balluff d.o.o.  
Livadna ulica 1  
SLO-2204  
Miklavž na Dravskem polju  
Phone +386 2 6 29 03 00  
Fax +386 2 6 29 03 02  
senzorji.sb@siol.net  
www.senzorji-sb.si

**Spain**  
Elion, S.A.  
Farell, 5  
E-08014 Barcelona  
Phone +34 93 298 20 00  
Fax +34 93 431 18 00  
elion@elion.es  
www.elion.es

**Switzerland**  
(French)  
Fritz Kübler S.à.r.l.  
2 rue de Grande Bretagne  
F-68310 Wittelsheim  
Phone +33 3 89 53 45 45  
Fax +33 3 89 53 66 77  
info@kuebler-sarl.com  
www.kuebler.fr

(Italian)  
Kübler Italia Srl.  
Viale Sarca, 96  
I-20125 Milano MI  
Phone +39 026 423 345  
Fax +39 026 611 3843  
info@kuebler.it  
www.kuebler.it

(German)  
Fritz Kübler GmbH  
Schubertstraße 47  
D-78054  
Villingen-Schwenningen  
Phone +49 7720 39 03-58  
Fax +49 7720 21 56 4  
vedrana.sollic@kuebler.com  
www.kuebler.com

**Turkey**  
Kübler Turkey Otomasyon  
Ticaret Ltd. Sti.  
Yeni mahalle Balikesir Cad.  
Uprise Elit Residence C1 AB Blok  
No:180 Soganklik  
TR - 34880 Kartal/Istanbul  
Phone +90 216 999 9791  
Fax: +90 216 999 9784  
cengizhan.temurcin@kuebler.com  
www.kuebler.com

• Encoders, process devices  
and transmission technology:  
Sanil Teknik  
Elektrik San. ve Tic. Ltd. Sti.  
Okçumusa Caddesi  
Tusak Sokak  
No: 27/5 Karaköy  
TR-34420 Istanbul  
Phone +90 212 256 94 28  
Fax +90 212 256 94 04  
sanil@sanil.com.tr  
www.sanil.com.tr

• Counters:  
ERUZ Elektrik San. ve Tic. A.S.  
Necatibey Caddesi  
Sait Demirbag Han No.5 K.1  
TR-34425 Istanbul  
Phone +90 212 2 93 60 36  
Fax +90 212 2 44 51 56  
eruzelektrik@eruzelektrik.com.tr  
www.eruzelektrik.com.tr

**Ukraine**  
SV Altera Ltd.  
4, Ivana Lepshe blvd, Kyiv,  
UA-03680 Ukraine  
Phone +38 044 496-18-88  
Fax +38 044 496-18-18  
office@sv-altera.com  
www.svaltera.ua

## America, Asia, Australia, Africa

### Catalogue distributors: (Europe)

**Austria** .....  
Farnell GmbH  
Birkenstrasse 2  
A-5300 Salzburg/Hallwang  
Phone +43 662 - 218 06 80  
Fax +43 662 - 218 06 70  
verkauf.at@farnell.com  
www.farnell.at

RS Components  
Albrechtser Straße 11  
A-3950 Gmünd  
Phone +43 28 52 505  
Fax +43 28 52 53 223  
www.rs-components.at

**France** .....  
RS Components SAS  
Rue Norman King BP 40453  
F-60031 Beauvais CEDEX  
Phone +33 3 44 10 16 48  
Fax +33 3 44 10 16 44  
www.radiospares.fr

Farnell France SAS  
81-83 rue Henri Depagneux  
BP 60426 Limas  
F-69654 Villefranche sur  
Saône  
Cedex  
Phone +33 4 74 68 99 99  
Fax +33 4 74 68 99 90  
ventes@farnell.com  
www.farnell.fr

**Great Britain** .....  
RS Components Ltd.  
PO Box 99, Corby  
GB-Northants NN17 9RS  
Phone +44 84 58 50 99 00  
Fax +44 15 36 40 56 78  
www.rs-components.com

Farnell  
Canal Road  
GB-Leeds, LS12 2TU  
Phone +44 8447 11 11 11  
Fax +44 8447 11 11 13  
sales@farnell.co.uk  
www.farnell.co.uk

**Italy** .....  
RS Components S.p.A.  
Via De Vizzi 93/95  
I-20092, Cinisello Balsamo,  
Milano  
Phone +39 02 660 581  
Fax +39 02 660 580 51  
www.rs-components.it

Distrelec Italia s.r.l.  
Via Canova 40/42  
I-20020 Lainate (Mi)  
Phone +39 02 - 93 75 51  
Fax +39 02 - 93 75 57 55  
info-it@distrelec.com  
www.distrelec.com

**Switzerland** .....  
Distrelec AG  
Grabenstraße 6  
CH-8606 Nänikon  
Phone +41- 44 9 44 99 11  
Fax +41- 44 9 44 99 88  
www.distrelec.com

Farnell AG  
Brandschenkestr. 178  
Postfach 1703  
CH-8027 Zürich  
Phone +41 1 - 204 64 64  
Fax +41 1 - 204 64 54  
verkauf.ch@farnell.com  
www.farnell.ch

Micronor AG  
Pumpwerkstraße 32  
CH-8105 Regensdorf  
Phone +41 44 843 40 20  
Fax +41 44 843 40 39  
sales@micronor.ch  
www.micronor.ch

**Argentina** .....  
AUMECON S.A.  
Acassuso 4768  
1605 Munro  
Prov. de Buenos Aires  
Phone +54 11 47 56 1251  
Fax +54 11 47 62 63 31  
ventas@amecon.com.ar  
www.amecon.com.ar

**Australia** .....  
Balluff Leuze Pty. Ltd.  
12 Burton Court  
Bayswater, Vic. 3153  
Phone +61 3 97 20 41 00  
Fax +61 3 97 38 26 77  
sales@balluff.com.au  
www.balluff.com.au

**Brazil** .....  
Balluff Controles Elétricos Ltda.  
Rua Francisco Foga 25,  
Cx. Postal 189  
CEP 13280-000 Vinhedo-SP  
Phone +55 19 38 76 99 99  
Fax +55 19 38 76 99 90  
vendas@balluff.com.br  
www.balluff.com.br

**Canada** .....  
Turck Chartwell Canada Inc.  
140 Duffield Drive  
Markham, Ontario L6G 1B5  
Phone +1 905 513 7100  
Fax +1 905 513 7101  
sales@www.chartwell.ca  
www.chartwell.ca

**China** .....  
Kuebler (Beijing) Automation  
Trading Co. Ltd.  
Rm 1603, B Area, Tower 2,  
Wangjing Soho,  
No.1 Futong East Street,  
Chaoyang, Beijing,  
China,100102  
Phone +86 10 8471 0818  
Fax: +86 10 8471 0819  
beijing@kuebler.com  
www.kuebler.com

**Egypt** .....  
AEE Advanced Electronic  
Engineering Co.  
3 Hassana El-Sheraie St.Off  
El-Horiya St-Heliopolis  
Cairo  
Phone +20 2 2418 50 20  
Fax +20 2 2415 92 65  
hfarid@aecontrols.com  
www.aeecontrols.com

**Hong Kong** .....  
Po Kwong Electric (HK) Ltd.  
Rm. 177-180, 1/F, Blk C,  
Hang Wai Ind. Ctr.,  
6 Kin Tai St., Tuen Mun, N.T  
Phone +852 24 23 66 22  
Fax +852 24 61 10 02  
sales@pokwong.com  
www.pokwong.com

**India** .....  
Kuebler Automation India Pvt Ltd  
Plot No 677, S. No. 269/3,  
Paud Road, Bhugaon,  
Pune 412 115,  
Maharashtra  
Phone +91 99 7065 5599  
Tel. +91 20 6790 1-200 / 230 /  
214 / 202  
Fax +91 20 6790 1232  
info@kuebler.in  
www.kuebler.in

Rajdeep Automation Pvt. Ltd.  
G3A, Anand Estate, Ground floor  
Sane Guruji Marg, Mahalaxmi  
Mumbai 400 011  
Phone +91 22 23 00 28 37 / 8  
Fax +91 22 23 00 2839  
info@rajdeep.in  
www.rajdeep.in

**Indonesia** .....  
SUPRA Engineering  
Jl. Pecenongan 17 D  
RI-10120 Jakarta  
Phone +62 21 345 73 55  
Fax +62 21 345 73 18  
astina@centrin.net.id  
www.supra.co.id

**Israel** .....  
Omega Engineering  
P.o.Box 190  
Ein Carmel 30860  
Phone +972-4-9544993  
Fax +972-4-9544992  
info@omegae.net  
www.omegae.net

**Lebanon** .....  
Industrial Technologies S.A.L  
(ITEC)  
Blvd. Fouad Chehab  
Point Center, Sin El Fil, Beirut  
Phone +961 (1) 491161  
Fax +961 (1) 491162  
info@iteclb.com  
www.iteclb.com

**Malaysia** .....  
dpstar Smart Solutions Sdn Bhd  
No. 37-1, Jalan OP 1/2  
Pusat Perdagangan One Puchong,  
Off Jalan Puchong,  
47160 Puchong,  
Selangor Darul Ehsan,  
Malaysia  
Phone +603 8074 8866  
Fax +603 8074 8666  
chrisliu@dpstar.com.my  
www.dpstar.com.my

**Mexico** .....  
Turck Mexico S.de R.L.de C.V.  
Parque Industrial La Angostura  
Zacatecas Km 4.5 Nave 8A  
Saltillo, Coahuila 25315  
Phone +52 844 411 6650  
Toll Free: 01-800-01-TURCK  
(Mexico only)  
Fax +52 844 482 6926  
mexico@turck.com  
www.turck.com.mx

**Morocco** .....  
r2i Consult SARL  
109 rue Montaigne Val  
Fleuri Maarif Casablanca  
Maroc  
Phone +212522986960  
Fax +212522989537  
info@r2imaroc.ma  
www.r2imaroc.ma

**New Zealand** .....  
Carrel-Electrade Ltd.  
P.O. Box 11-078  
Eilerslie  
NZ-Auckland 1542  
Phone +64 95251753  
Fax +64 95251756  
sales@carrel-electrade.co.nz  
www.carrel-electrade.co.nz

**Peru** .....  
Techpro SAC  
Calle Alberto del Campo 414  
Magdalena del Mar  
Lima 17 - Peru  
Phone +51 98943 58-54  
Fax +51 17272 685  
techpro.peru@techprocorp.net  
www.techprocorp.net

**Philippines** .....  
Technorand Sales Coporation  
122 McArthur Highway  
O Malabon, Metro Manila  
Phone +632 985 07 05  
Fax +632 716 59 86  
technorand@gmail.com

**Singapore** .....  
Raymond International Pte. Ltd.  
Blk 219 Henderson Road #07-04  
Henderson Industrial Park  
Singapore 159556  
Phone +65 62 76 37 38  
Fax +65 62 76 37 39  
sales@raymondcom.com  
www.raymondcom.com

**South Africa** .....  
Kübler Group  
Fritz Kübler GmbH  
Schubertstr. 47  
78054 Villingen-Schwenningen  
Phone +49 7720 3903-0  
Fax +49 7720 21564  
info@kuebler.com  
www.kuebler.com

**South Korea** .....  
Kuebler Korea (by F&B)  
578, Kwabop-dong, Sasang-ku  
Pusan Industrial Supplies  
Market 9-116  
PUSAN  
Phone +82 51 319 12 30  
Fax +82 51 319 12 50  
fnb@kuebler.co.kr  
www.kuebler.kr

**Taiwan, R.O.C.** .....  
• Encoders, transmission  
technology:  
E-Sensors & Automation Int'l Corp.  
6F-2, No.109, Chien Kuo 1st Rd.  
Kaohsiung 80284  
Taiwan, R.O.C.  
Phone +886-7-7220371  
Fax +886-7-7718161  
ez-corp@umail.hinet.net  
www.e-sensors.com.tw

• Electronic counters and  
process devices:  
Canaan Electric Corp.  
6F-5, No. 63, Sec. 2  
Chang An East Road  
Taipei  
Phone +886 225 08 23 31  
Fax +886 225 08 47 44  
sales@canaan-elec.com.tw  
www.canaan-elec.com.tw

**Thailand** .....  
Technology Instruments Co. Ltd.  
549/9 Onnut Road Kwaeng  
Pravet, Khet Pravet  
Bangkok 10250  
Phone +662 74 388 88  
Fax +662 74 388 43  
marketing@tic.co.th  
www.tic.co.th

**Tunisia** .....  
H2M Technologies  
13, Rue El Moutanabi  
TN-2037 El Menzah 7 - Tunis  
Phone +216 71 42 76 77  
Fax +216 71 42 76 88  
h2m.tech@planet.tn

**U.S.A.** .....  
**Kuebler Inc.**  
5245-3 Old Dowd Road  
Charlotte, NC 28208  
Phone +1-704-705-4711  
Toll Free +1-855-KUEBLER  
(583-2537)  
Fax +1-704-733-9170  
usa@kuebler.com  
www.kuebler.com/usa

• Counting and process  
technology:  
Global Industrial Products Inc.  
8129 North Austin AVE  
Morton Grove, IL 60053  
Toll-free number:  
1-800-951-8774  
Phone 847 965 9808  
Fax 847 901 9846  
sales@globalepower.com  
www.kueblerusa.com

**United Arab Emirates** .....  
Baer Measurements LLC  
P.O. Box 111393  
Al Gaiht Tower 505,  
Hamdan Street  
Abu Dhabi - UAE  
Phone +971 2 627 2097  
Fax +971 2 627 2091  
info@bml.ae  
www.bml-international.com

**Vietnam** .....  
GNN Co., Ltd  
153, Nguyen Van Thu  
Da Koa Ward, District 1  
Ho Chi Minh City  
Phone +84 8 3517 4923  
Fax +84 8 3517 4924  
contact@gnnvietnam.com  
www.gnnvietnam.com

## Contact partners in Germany

### PLZ 01000 ... 09999

**PLZ 15000 ... 15999**  
Kübler Vertriebsbüro Süd-Ost  
Lars Meyer  
Durchfahrt 9  
09569 Oederan  
Phone +49 37292 283500  
Fax +49 37292 283501  
lars.meyer@kuebler.com

### PLZ 10000 ... 14999

**PLZ 16000 ... 19999**  
**PLZ 20000 ... 32999**  
**PLZ 38000 ... 39999**  
Kübler Vertriebsbüro Nord  
Hermi Herrmann  
Mohnblumenweg 6  
28876 Oyten  
Phone +49 4207 6880-32  
Fax +49 4207 6880-34  
hermi.herrmann@kuebler.com

### PLZ 33000 ... 33999

Kübler Vertriebsbüro West  
Torsten Czubkowski  
Auf der Ümcke 11 a  
59757 Arnsberg  
Phone +49 2932 891898  
Fax +49 2932 53311  
torsten.czubkowski@kuebler.com

### PLZ 34000 ... 37999

Kübler Vertriebsbüro Mitte  
Stefan Heinigk  
Gartenstraße 10  
35759 Driedorf  
Phone +49 2775 578427  
Fax +49 2775 578428  
stefan.heinigk@kuebler.com

### PLZ 40000 ... 47999

Kübler Vertriebsbüro West  
Torsten Czubkowski  
Auf der Ümcke 11a  
59757 Arnsberg  
Phone +49 2932 891898  
Fax +49 2932 53311  
torsten.czubkowski@kuebler.com

### PLZ 48000 ... 49999

Kübler Vertriebsbüro Nord  
Hermi Herrmann  
Mohnblumenweg 6  
28876 Oyten  
Phone +49 4207 6880-32  
Fax +49 4207 6880-34  
hermi.herrmann@kuebler.com

### PLZ 50000 ... 54999

**PLZ 55300 ... 55999**  
**PLZ 56500 ... 56999**  
**PLZ 58000 ... 59999**  
Kübler Vertriebsbüro West  
Torsten Czubkowski  
Auf der Ümcke 11a  
59757 Arnsberg  
Phone +49 2932 891898  
Fax +49 2932 53311  
torsten.czubkowski@kuebler.com

### PLZ 55000 ... 55299

**PLZ 56000 ... 56499**  
**PLZ 57000 ... 57999**  
Kübler Vertriebsbüro Mitte  
Stefan Heinigk  
Gartenstraße 10  
35759 Driedorf  
Phone +49 2775 578427  
Fax +49 2775 578428  
stefan.heinigk@kuebler.com

### PLZ 60000 ... 65999

**PLZ 67000 ... 67599**  
**PLZ 68000 ... 69999**  
Kübler Vertriebsbüro Mitte  
Stefan Heinigk  
Gartenstraße 10  
35759 Driedorf  
Phone +49 2775 578427  
Fax +49 2775 578428  
stefan.heinigk@kuebler.com

### PLZ 66000 ... 66999

**PLZ 67600 ... 67999**  
Kübler Vertriebsbüro West  
Torsten Czubkowski  
Auf der Ümcke 11a  
59757 Arnsberg  
Phone +49 2932 891898  
Fax +49 2932 53311  
torsten.czubkowski@kuebler.com

### PLZ 70000 ... 79999

Kübler Vertriebsbüro Süd-West  
Philipp Lang  
Lembergstraße 6  
72119 Ammerbuch-Altingen  
Phone +49 7032 2293665  
Fax +49 7032 2993454  
philipp.lang@kuebler.com

### PLZ 80000 ... 87999

**PLZ 89200 ... 89499**  
Kübler Vertriebsbüro Süd  
Bernhard Preißler  
Am Seeacker 8  
93326 Abensberg  
Phone +49 9443 9186926  
Fax +49 9443 9186974  
bernhard.preissler@kuebler.com

### PLZ 88000 ... 89199

**PLZ 89500 ... 89999**  
Kübler Vertriebsbüro Süd-West  
Philipp Lang  
Lembergstraße 6  
72119 Ammerbuch-Altingen  
Phone +49 7032 2293665  
Fax +49 7032 2993454  
philipp.lang@kuebler.com

### PLZ 90000 ... 93999

**PLZ 95000 ... 95999**  
Kübler Vertriebsbüro Süd-Ost  
Lars Meyer  
Durchfahrt 9  
09569 Oederan  
Phone +49 37292 283500  
Fax +49 37292 283501  
lars.meyer@kuebler.com

### PLZ 94000 ... 94999

Kübler Vertriebsbüro Süd  
Bernhard Preißler  
Am Seeacker 8  
93326 Abensberg  
Phone +49 9443 9186926  
Fax +49 9443 9186974  
bernhard.preissler@kuebler.com

### PLZ 96000 ... 99999

Kübler Vertriebsbüro Mitte  
Stefan Heinigk  
Gartenstraße 10  
35759 Driedorf  
Phone +49 2775 578427  
Fax +49 2775 578428  
stefan.heinigk@kuebler.com

### Approved system partners/ distributors

**22149 Hamburg**  
Hermann Seidel GmbH  
Techn. Vertretungen  
Rahlstedter Str. 16  
Phone +49 40 675085-0  
Fax +49 40 675085-85  
info@seidel-gmbh.de  
www.seidel-gmbh.de

**42499 Hückeswagen**  
Fuhrmeister + Co. GmbH  
Industrie-Elektronik  
Stahlschmidtsbrücke 61  
Phone +49 2192 851122  
Fax +49 2192 851127  
info@fuhrmeister-gmbh.de  
www.fuhrmeister-gmbh.de

**66287 Göttelborn**  
Herbert Neundorfer  
GmbH & Co. KG  
Werksvertretungen  
Am Campus 5  
Phone +49 6825 9545-0  
Fax +49 6825 9545-99  
info@herbert-neundoerfer.de  
www.herbert-neundoerfer.de

**82069 Hohenschäftlarn**  
Bachmann  
Electronic GmbH  
Am Wagnerfeld 4  
Phone +49 8178-8676-0  
Fax +49 8178-8676-50  
info@bachmann-electronic.de  
www.bachmann-electronic.de

### Catalogue distributors (Germany):

**28359 Bremen**  
Distrelec Schuricht GmbH  
Lise Meitner-Str. 4  
Phone +49 1805 2234-35  
Fax +49 1805 2234-36  
scc@distrelec.de  
www.distrelec.de

**64546 Mörfelden-Walldorf**  
RS Components GmbH  
Hessenring 13 b  
Phone +49 6105 401234  
Fax +49 6105 401100  
www.rs-components.de

**82041 Oberhaching**  
Farnell GmbH  
Keltnering 14  
Phone +49 89 61393939  
www.farnell.de

**92240 Hirschau**  
Conrad Electronic SE  
Klaus-Conrad-Straße 1  
92240 Hirschau  
Phone +49 9604 408 787  
www.conrad.com

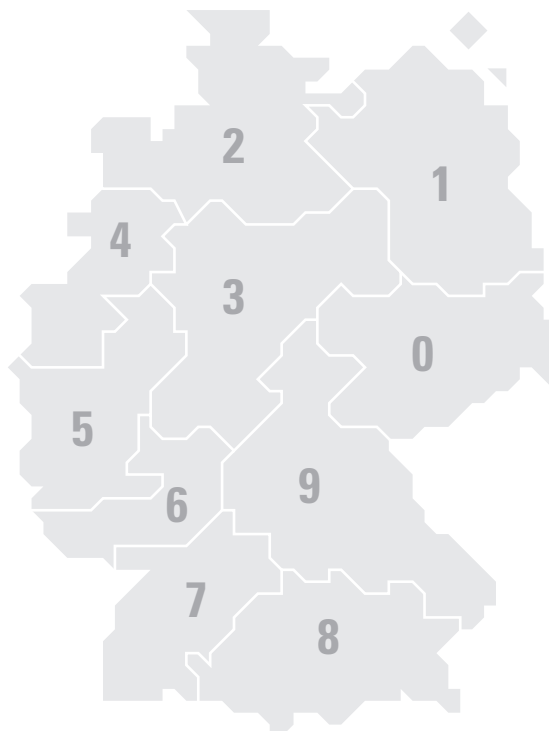





**Kubler**

[www.kuebler.com](http://www.kuebler.com)

The logo for Kübler, featuring a stylized orange 'C' shape to the left of the word 'Kübler' in a bold, orange, sans-serif font.



Transmission Technology

**Kübler Group**  
**Fritz Kübler GmbH**  
Schubertstrasse 47  
D-78054 Villingen-Schwenningen  
Germany  
Phone +49 7720 3903-0  
Fax +49 7720 21564  
[info@kuebler.com](mailto:info@kuebler.com)  
[www.kuebler.com](http://www.kuebler.com)

 *pulses for automation*

R.600.948.001 02 000 15 ES