

**Thank you for choosing a NIVELCO instrument.
We are sure that you will be satisfied throughout its use!**

NIVOCAP

RF - CAPACITANCE
LEVEL SWITCH

USER'S MANUAL



NIVELCO

1. APPLICATION

The **NIVOCAP CK** capacitance level switches operate in the RF (radio-frequency) ~ 130 kHz range. The instrument is less sensitive to deposits provided by the so-called reference probe construction.

The RF operation principle and the probe construction make the instrument suitable for detecting level of powders and solid materials with relative dielectric constant greater than 1.5 and liquids.

The device needs to be calibrated after the installation.

During the operation the electronics continuously evaluates the capacitance difference of the connected measurement probe. Until the probe and its close surrounding are free in the air (the medium to be measured don't reach the probe) the minimal capacitance of the measuring and the reference probe is constant ($\epsilon_{relative}=1$) compared to the instrument housing. When the medium reaches the probe the basic capacitance will increase ($\epsilon_{relative}>1$). The electronic measures this capacitance change compared to an initial capacitance value recorded by the calibration procedure.

The reference probe construction allows that the material build-ups on the probe can be ignored preventing false switching.

The measurement can be done in four ranges (see Chapter 4: Sensitivity range selection)

4th sensitivity range: 0.5 pF, $\epsilon_{relative}$ = between 1.5 – 2.0

3rd sensitivity range: 2.5 pF, $\epsilon_{relative}$ = between 2.0 – 4.0

2nd sensitivity range: 8.0 pF, $\epsilon_{relative}$ = between 4.0 – 7.0

1st sensitivity range: 18 pF, $\epsilon_{relative}$ > 7.0

2. TECHNICAL DATA

2.1 GENERAL DATA

TYPE	STANDARD CK(D,G,M,P,H,N)-1□□-1 CM(D,G,M,P,H,N)-1□□-1	ROD EXTENDED CKR-1□□-1, CKL-1□□-1 CMR-1□□-1 CML-1□□-1	CABLE EXTENDED CKK-1□□-1 CKC-1□□-1
Probe length	300, 400, 500-600 mm	0.7 ... 3 m	1 ... 10 m
Material of wetted parts	1.4571		1.4571 / antistatic PP
Housing material	Paint coated aluminium		
Process connection	As per order code		
Ambient temperature	-30 °C...+65 °C		
Medium temperature range	-30 °C...+110 °C	-25 °C...+90 °C	
Medium temperature range for high temperature types	-30 °C...+220 °C	-	
Max. process pressure	3 bar (0.3 MPa)	3 bar (0.3 MPa)	
Response time (selectable)	0.15 – 15 sec		
Supply voltage (universal)	20...255 V AC/DC		
Power consumption	≤ 2.5 VA / 2 W		
Ingress protection	IP67 (NEMA6) EN 60529:2001		
Electrical protection	Class I. (to be grounded!)		
Ex marking (only with aluminium housing)	...		
Mass	... kg	... kg	... kg

2.2 SPECIAL DATA

OUTPUT DATA	RELAY C□□-1□□-1	SOLID STATE C□□-1□□-3
	Output type	SPDT (potential free)
Output rating	250 V AC, 8A, AC 1	50V, 350 mA
Output protections	—	Varistor

2.4 ORDER CODES

NIVOCAP C □ □ - 1 □ □ - □

VERSION	CODE	PROBE TYPE / PROCESS CONN.	CODE	HOUSING	CODE	PROBE LENGTH	POWER SUPPLY / OUTPUT / EX	CODE
Standard	K	Standard 3/4" BSP	D	Aluminium	1	0 0 m	20-255 V AC/DC / Relay	1
High temp.	M	Standard 3/4" NPT	G			1 1 m	20-255 V AC/DC / Electronic	3
		Standard / 1" BSP	M			2 2 m	20-255 V AC/DC / Relay / Ex tD	5*
		Standard / 1" NPT	P			3 3 m	20-255 V AC/DC / Electronic / Ex tD	7*
		Standard / 1 1/2" BSP	H			4 4 m		
		Standard / 1 1/2" NPT	N			5 5 m		
		Cable extended / 1 1/2" BSP	K			6 6 m		
		Cable extended / 1 1/2" NPT	C			7 7 m		
		Rod extended 3/4" BSP	E			8 8 m		
		Rod extended 3/4" NPT	F			9 9 m		
		Rod extended / 1" BSP	V			A 10 m		
		Rod extended / 1" NPT	Z					
		Rod extended / 1 1/2" BSP	R					
		Rod extended / 1 1/2" NPT	L					

* Under approval!

Cable extended types: from 1 m up to 10 m, with 0.5 m steps!

Rod extended types: from 0.7 m up to 3 m, with 0.1 m steps!

Standard types: CK□-103, CK□-104, CK□-105, CK□-106

2.5 DIMENSIONS

STANDARD	ROD EXTENDED	CABLE EXTENDED	HIGH TEMPERATURE VERSION WITH STANDARD PROBE	HIGH TEMPERATURE VERSION WITH ROD EXTENDED PROBE
CKM-1□□-1, CKP-1□□-1	CKR-1□□-1, CKL-1□□-1	CKK-1□□-1, CKC-1□□-1	CMM-1□□-1, CMP-1□□-1	CMR-1□□-1, CML-1□□-1

3. MOUNTING

Prior to installation, it is advised to check the switching function for proper adjustment on a sample quantity of material.

WARNING! Handle the device with great care, especially the sensing probe. Any strong impact or bending on the sensing probe may damage the device. A protective shield should be installed (see the figure) if the probe is exposed to falling material or excessive mechanical load.

Screw in the device by its hexagon neck. After screwing tight the process connection, the housing can be rotated (max. 300°), to adjust the cable gland to the required position.

It might be necessary to install the device at an offset level position relative to the switching level actually required taking into account caving or arching of the material in the silo.

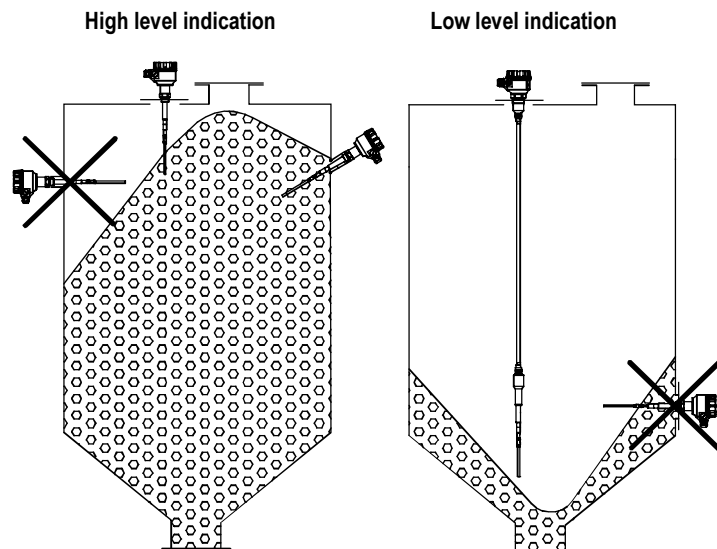

RECOMMENDED

NOT RECOMMENDED

In case of powder level detection the device should be installed that the inclination of the side mounted probe should be greater than the angle of repose (or, in case of high level detection vertically), to prevent powder deposition on the probe that might cause false switching. Also avoid mounting the unit near to recess or near to any surface that facilitate build-up forming.

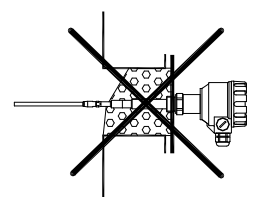
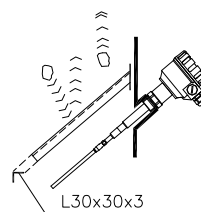

In case of tanks that are likely to be exposed to intense vibrations the electronic output versions should be applied.

4. INSTALLATION, PUTTING INTO OPERATION

4.1. BASIC CONCEPTS

Response (delay) time adjustment potentiometer: DELAY

The instrument senses the material when it reaches the probe and the switching is performed only after a selected time interval (0 sec – 15 sec). This delay time can be user selected by the delay time potentiometer between 0 sec and 15 sec. The delay time can be increased by turning the potentiometer to the right.

When the material sets the probe free the switching is also performed only after the selected time delay.

If the „material presence“ or „material non-presence“ state changes during the delay time, the delay time starts again.

Sensitivity fine adjustment potentiometer: FINE SENS

Further fine sensitivity adjustment can be done within the selected sensitivity range by a potentiometer. The sensitivity can be increased by turning the potentiometer to the right.

Sensitivity range selecting push button: SENS

This push button allows to select the required sensitivity range. To change over the ranges press the button repeatedly.

Fail-safe switch: F – S (H – S)

The low and high fail safe mode can be selected by the fail-safe switch.

The fail-safe indication is performed by de-energized state relay output (see the operation diagram table)

High Fail – safe:

The probe senses the material, but the relay remains in de-energized state similarly to in case of power failure.

Low Fail – safe:

The probe not senses the material, but the relay remains in de-energized state similarly to in case of power failure.

4.2. PUTTING INTO OPERATION

Remove the housing cover to access the connection points and the control elements.

The output should be protected by a 2A time delay fuse in case of electronic output versions.

The instrument should be configured and calibrated after the installation and the wiring.

ATTENTION! The instrument may be damaged by electrostatic discharge (ESD) via its terminal, thus apply the precautions commonly used to avoid electrostatic discharge e.g. by touching a properly grounded point before removing the cover of the enclosure.

The RF-capacitance level switch will function incorrectly if:

- The relative dielectric constant of the measured medium is under 1.5.
- There is a connection bridge between the probe and the tank wall.
- The instrument has improper grounding.
- The insulation on the probe is damaged.
- The probe is not properly assembled.

4.3. CALIBRATION

Calibration push button: CAL

The calibration should be performed after the installation. The instrument housing should be grounded. Press the CAL button for a few seconds.

The blue LED will light first, then it will be blinking and then the LED will show the colour of the relating operation state as indicating the successful calibration procedure

The calibration procedure contribute that after the installation the capacitance change occurring in the tank will be learned by the electronics and considered as initial reference capacitance value.

If the unit is installed in hazardous (Dust Ex) environment where the housing cover is not allowed to remove when the unit is energized, the calibration can be done without removing the housing cover by a magnet. The supplied permanent magnetic screw allows performing the calibration procedure through the aluminium housing.

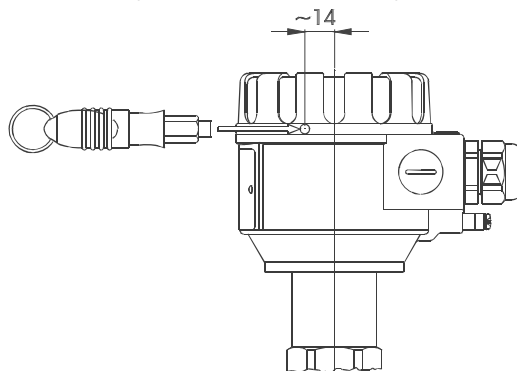

This case the status LED will blink blue during the calibration. All the other configuration settings (Sensitivity range selection, Sensitivity fine adjustment, Delay adjustment, Fail-safe operation mode selection and switching the Magnetic Calibration switch to ON state) should be carried out outside the hazardous environment (e.g. in the control room) before mounting the instrument.





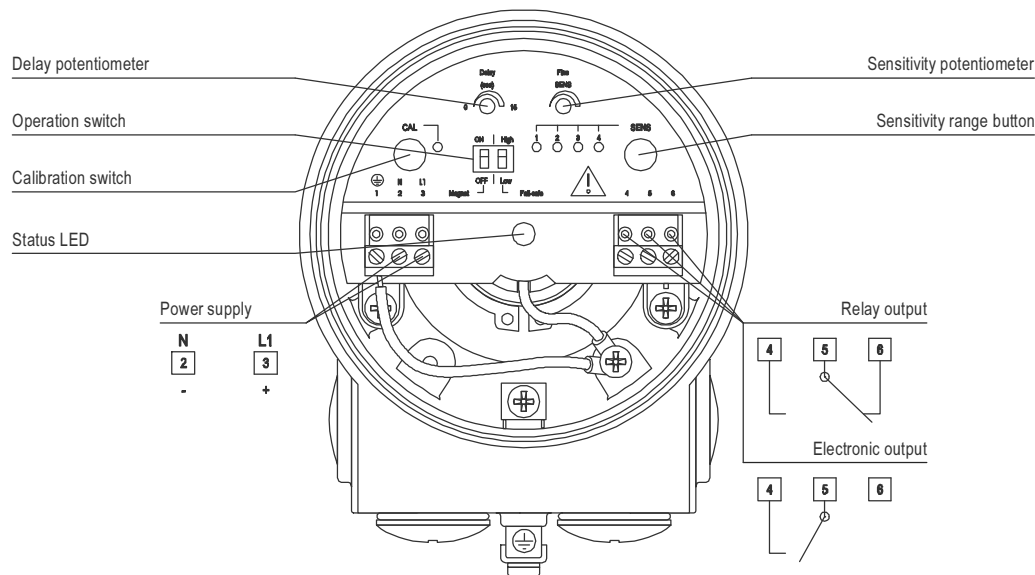

The calibration can be performed multiple times.

5. WIRING

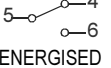

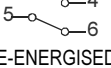
Wiring of relay and electronic output versions

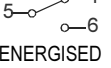
5.1 OPERATION DIAGRAM

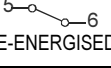
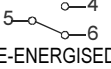
POWER	OPERATION	FAIL-SAFE MODE	STATUS LED	RELAY	SOLID STATE OUTPUT
ON	High level	 HIGH	GREEN BLINKING	 ENERGISED	5 and 4 ON
		 HIGH	RED LIGHT	 DE-ENERGISED	5 and 4 OFF
	Low level	 LOW	GREEN LIGHT	 ENERGISED	5 and 4 OFF
		 LOW	RED BLINKING	 DE-ENERGISED	5 and 4 ON
OFF	—	HIGH or LOW	NOT LIT	 DE-ENERGISED	5 and 4 OFF

6. MAINTENANCE AND REPAIR

The NIVOCAP CK-100 series devices do not require maintenance on a regular basis. In some instances, however, the probe may need a cleaning from deposited material. **This must be carried out gently, without harming the probe.**

Repairs during or after the warranty period are effected at the Manufacturers. The equipment sent back for repairs should be cleaned or neutralized (disinfected) by the User.

7. STORAGE

Ambient temperature: -35 ... +60°C

Relative humidity: max. 98 %

8. WARRANTY

NIVELCO provides warranty of 3 (three) years in compliance with details described in the Warranty Card.

ckm1051a0600h_01.doc

March 2013.

NIVELCO reserves the right to change technical data without notice.