

# PiLoTREK

W-100

2-wire non-contact  
microwave compact level transmitter

User's and Programming manual  
4<sup>th</sup> edition





---

Manufacturer:  
**NIVELCO Process Control Co.**  
H-1043 Budapest, Dugonics u. 11.  
Tel.: (36-1) 889-0100 ■ Fax: (36-1) 889-0200  
E-mail: [sales@nivelco.com](mailto:sales@nivelco.com) ■ [www.nivelco.com](http://www.nivelco.com)

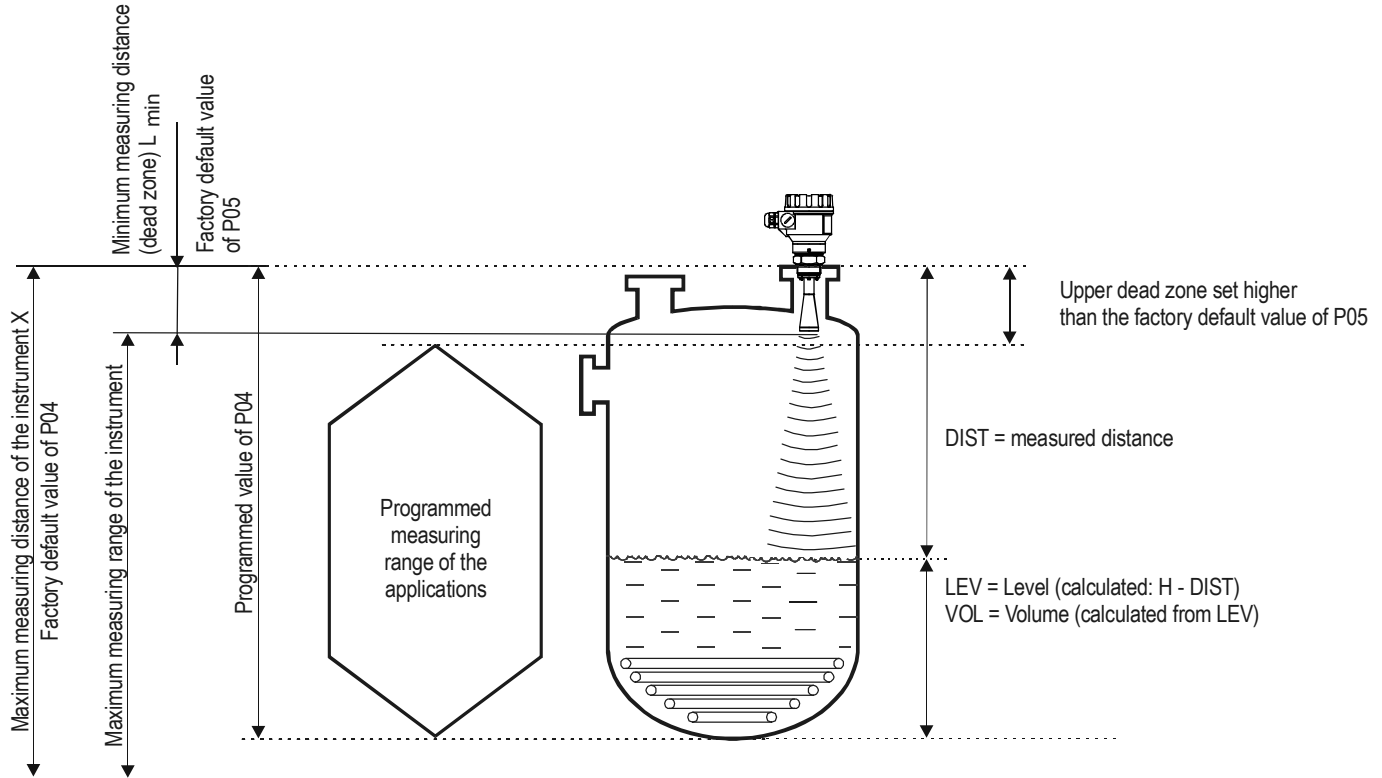

# BASIC CONCEPTS OF MICROWAVE LEVEL MEASUREMENT



# TABLE OF CONTENTS

1. INTRODUCTION .....	5
2. ORDER CODES .....	6
3. TECHNICAL DATA .....	7
3.1. EXPLOSION PROTECTION, EX MARKINGS, EX LIMIT DATA .....	8
3.2. DIMENSIONS AND SPECIAL DATA OF THE ANTENNA VARIATIONS .....	9
3.2.1. DETERMINE THE MAXIMAL MEASURING RANGE .....	15
3.3. ACCESSORIES .....	16
3.4. CONDITIONS OF SAFE OPERATION .....	16
3.5. REPAIR AND MAINTENANCE .....	16
4. INSTALLATION .....	17
4.1. MOUNTING .....	17
4.2. WIRING .....	19
4.2.1. WIRING OF THE DEVICES .....	20
4.2.2. DETERMIN THE APPROPRIATE POWER SUPPLY VOLTAGE .....	21
4.3. LOOP CURRENT CHECKING WITH HAND INSTRUMENT .....	22
5. PROGRAMMING .....	22
5.1. THE SAP-300 DISPLAY UNIT .....	23
5.1.1. PRIMARY MEASUREMENT SCREEN .....	23
5.1.2. INFORMATION SCREENS .....	25
5.1.3. ECHO MAP .....	26
5.2. PROGRAMMING WITH THE SAP-300 DISPLAY MODULE .....	27
5.2.1. COMPONENTS OF THE PROGRAMMING INTERFACE .....	27
5.2.2. MENU STRUCTURE .....	28
5.3. PROGRAMMABLE FEATURES DESCRIPTION .....	29
5.3.1. BASIC MEASUREMENT SETTINGS .....	29
5.3.2. ANALOGUE OUTPUT .....	30
5.3.3. DIGITAL OUTPUT .....	32
5.3.4. MEASUREMENT OPTIMIZATION .....	32
5.3.5. CALCULATIONS .....	34
5.3.6. SERVICE FUNCTIONS .....	37
6. ERROR CODES .....	39
7. PiLoTREK W-100 PARAMETER TABLE .....	40
8. MENUMAP .....	42



*Thank you for choosing a NIVELCO instrument.  
We are sure that you will be satisfied throughout its use!*

## 1. INTRODUCTION

### Application

The **PiloTREK W-100** non-contact microwave level transmitters provide the most advanced, new generation measurement technique of the industrial process automation field. **PiloTREK** is an ideal solution of high precision level transmitting of liquids, slurries, dollops, emulsions and other chemicals in a wide range of application area, such as food industry, energy industry, pharmaceutical industry, chemical industry, and even in naval applications with mm accuracy range and high measuring stability.

**PiloTREK** is able to provide an excellent non-contact measurement solution for those substances which tend to steam, or for liquids with a gas layer. Since there is no need for a defined propagation medium in the case of microwaves, the **PiloTREK** is applicable in vacuum.

### Operation principle

The reflection of the emitted microwave impulses is considerably depending on the relative dielectric constant of the measured medium. The essential condition of microwave level measurement is that the relative dielectric constant ( $\epsilon_r$ ) of the medium should be more than 1.9.

The operation of the non-contact microwave level transmitters is based on the measurement of the time of flight of the reflected signals, so-called Time Domain Reflectometry (TDR) method.

The propagation speed of microwave impulses is practically the same in air, gases and in vacuum, independently from the process temperature and pressure, so the measured distance is not affected by the physical parameters of medium to be measured.

The **PiloTREK** level transmitter is a Pulse Burst Radar operating at 25 GHz (K-band) microwave frequency.

The 25 GHz models' most noticeable advantage over the lower frequency (5-12 GHz) radars are the smaller antenna size, the better focusing, lower dead-band and smaller transmission angle.

The level transmitter induces few nanosecond length microwave impulses in the antenna and a part of the energy of the emitted signals reflects back from the measurement surface depending on the measured media. The time of flight of the reflected signal is measured and processed by the electronics, and then this is converted to distance, level or volume proportional data.

## 2. ORDER CODES

Not all combinations possible!

PiloTREK W   - 1   -

FUNCTION	CODE
Compact transmitter	E
Transmitter + display	G
Integrated transmitter	P
High temperature transmitter	H
High temperature transmitter + display	J

ANTENNA / HOUSING MATERIAL	CODE
1.4571 / Aluminium housing	S
1.4571 / Plastic housing	M
PP / Plastic housing	P*
1.4571 / Stainless steel housing	K

ANTENNA / DIAMETER	CODE
DN40 Horn / 1½"	4
DN50 Horn / 2"	5
DN80 Horn / Flange	8

PROCESS CONNECTION	CODE
BSP	0
NPT	N
DN 80 PN25	2
DN 100 PN25	3
DN 125 PN25	4
DN 150 PN25	5
DN 80, PP	6
DN 100, PP	7
DN 125, PP	8
DN 150, PP	9
3" RF 150 psi	A
4" RF 150 psi	B
5" RF 150 psi	C
6" RF 150 psi	D
3" RF, PP	E
3" RF, PP	E
4" RF, PP	F
5" RF, PP	G
6" RF, PP	H
JIS 10K80A	J
JIS 10K100A	K
JIS 10K125A	L
JIS 10K 150A	M
JIS 80A, PP	P
JIS100A, PP	R
JIS125A, PP	S
JIS150A, PP	T

OUTPUT / EX	CODE
4 - 20 mA + HART	4
4 - 20 mA + HART / Ex	8

\* Ex version is not available



ACCESSORIES TO BE ORDERED NON-SEPARATELY	ORDER CODES
PP antenna enclosure with 1½" BSP threaded process connection	WAP-140-0
PP antenna enclosure with 1½" NPT threaded process connection	WAP-14N-0
PTFE antenna enclosure with 1½" BSP threaded process connection	WAT-140-0
PTFE antenna enclosure with 1½" NPT threaded process connection	WAT-14N-0
PP antenna enclosure with 2" BSP threaded process connection	WAP-150-0
PP antenna enclosure with 2" NPT threaded process connection	WAP-15N-0
PTFE antenna enclosure with 2" BSP threaded process connection	WAT-150-0
PTFE antenna enclosure with 2" NPT threaded process connection	WAT-15N-0
PTFE antenna enclosure with 2" TRICLAMP process connection	WAT-14T-0
PTFE antenna enclosure with DN50 Pipe coupling process connection	WAT-14R-0

### 3. TECHNICAL DATA

TYPE	PLASTIC HOUSING WOM-1□□-□, WOP-1□□-□	METAL HOUSING WOS-1□□-□ WOK-1□□-□	HIGH TEMPERATURE VERSION WHO-1□□-□, WJO-1□□-□
Measured and calculated values	Level, distance, volume, mass		
Measured media	Liquids		
Frequency of the measuring signal	~25 GHz (K-band)		
Minimal and maximal measuring range *	See chapter 3.2		
Material of wetted parts			
Process connection			
Beam angle			
Minimal $\epsilon_r$ of the medium*			
Maximal medium pressure (depending on the antenna)	25 bar (at 120 °C), with plastic antenna enclosure: 3 bar (at 25 °C)		
Medium temperature	-30 ... + 100 °C (up to max. 2 min.: 120 °C) with PP antenna enclosure: max.: 80 °C	-30 ... + 180 °C	
Ambient temperature	-20 ... +60 °C		
Resolution	1 mm		
Typical linearity error (as per EN 61298-2)*	< 0.5 m: ±25 mm, 0.5 - 1m: ±15 mm, 1 - 1.5 m: ±10 mm, 1.5 - 8 m: ±3 mm, > 8 m: ±0.04% of the measured distance		
Temperature error (as per EN 61298-3)	0,05% FSK / 10 °C (-20 ... +60 °C)		
Output	Analogue	4 - 20 mA (3.9 - 20.5 mA)	
	Digital communication	HART (minimal terminal resistor: 250 Ohm)	
	Display	SAP-300 graphical display unit	
Damping time	Selectable: 0 ...99 sec		
Measuring frequency	10..60 sec as per the application settings		
Error indication	Output = 22 mA or 3.8 mA		
Output load	$R_t = (U_i - 20V) / 0.022 A$ , $U_i$ = power supply voltage		
Power supply voltage	20 V ... 36 V DC, Ex: 20 V ... 30 V DC		
Electrical protection	Class III.		
Ingress protection	IP 67, integrated type: IP 68	IP 67	
Electrical connection	2x M 20 x1.5 cable glands + internal thread for 2x ½" NPT cable protective pipe, cable outer diameter: $\varnothing$ 7...13 mm, cross section: max.1.5 mm <sup>2</sup>		
Housing material	Plastic (PBT)	Paint coated aluminium (EN AC 4200), Stainless steel	
Sealing	Viton, EPDM		
Mass	1 - 1.6 kg	2 - 2.6 kg	2.7 - 3.3 kg

\* Examined in case of proper application settings at 95% sample rate level. The environment should be free of EMC noises and power supply voltage fluctuations in accordance to the standard, under constant temperature. The reflector should be a plane plate reflector with ideal material, surface and dimensions (min. 3m x 3m). The largest false echo should be 20 dB smaller than the useful echo.

### 3.1. EXPLOSION PROTECTION, EX MARKINGS, EX LIMIT DATA

TYPE	PLASTIC HOUSING TYPE WDM-1□□-□,	METAL HOUSING TYPE WOS-1□□-□ WOK-1□□-□	HIGH TEMPERATURE VERSION WITH METAL HOUSING WHO-1□□-□, WJO-1□□-□
IECEx (ia)	Ex ia IIB T6...T5 Ga/Gb Li: 200μH Ci: 16nF Ui:30V li:140mA Pi:1W	Ex ia IIB T6...T3 Ga Li: 200μH Ci: 16nF Ui:30V li:140mA Pi:1W	Ex ia IIB T6...T3 Ga Li: 200μH Ci: 16nF Ui:30V li:140mA Pi:1W
ATEX (ia)	 II 1/2 G Ex ia IIB T6...T5 Ga/Gb Li: 200μH Ci: 16nF Ui:30V li:140mA Pi:1W	 II 1G Ex ia IIB T6...T3 Ga Li: 200μH Ci: 16nF Ui:30V li:140mA Pi:1W	 II 1G Ex ia IIB T6...T3 Ga Li: 200μH Ci: 16nF Ui:30V li:140mA Pi:1W

Temperature limit data for hazardous atmospheres:

TEMPERATURE DATA FOR HAZARDOUS GAS ATMOSPHERES (II B GROUP)	PLASTIC HOUSING TYPE WDM-1□□-□		METAL HOUSING TYPE WOS-1□□-□, WOK-1□□-□			HIGH TEMPERATURE VERSION WITH METAL HOUSING WHO-1□□-□, WJO-1□□-□
Maximum permissible medium temperature at the antenna	+80°C	+80°C	+80°C	+90°C	+100°C	+180°C
Maximum permissible surface temperature at the process connection	+75°C	+80°C	+75°C	+90°C	+100°C	+175°C
Temperature class	<b>T6</b>	<b>T5</b>	<b>T6</b>	<b>T5</b>	<b>T4</b>	<b>T3</b>



## 3.2. DIMENSIONS AND SPECIAL DATA OF THE ANTENNA VARIATIONS

ALUMINIUM HOUSING, 1½" HORN ANTENNA WES-140-□, WGS-140-□, WES-14N-□, WGS-14N-□		ALUMINIUM HOUSING, 2" HORN ANTENNA WES-150-□, WGS-150-□ WES-15N-□, WGS-15N-□		PLASTIC HOUSING, 1½" HORN ANTENNA WEM-140-□, WGM-140-□, WEM-14N-□, WGM-14N-□		PLASTIC HOUSING, 2" HORN ANTENNA WEM-150-□, WGM-150-□ WEM-15N-□, WGM15N-□	
Material of wetted parts	1.4571, PTFE	1.4571, PTFE	1.4571, PTFE	1.4571, PTFE	1.4571, PTFE	1.4571, PTFE	1.4571, PTFE
Process connection	1½" BSP, 1½" NPT	2" BSP, 2" NPT	1½" BSP, 1½" NPT	1½" BSP, 1½" NPT	2" BSP, 2" NPT	2" BSP, 2" NPT	2" BSP, 2" NPT
Beam angle (-3dB)	19°	16°	19°	19°	16°	16°	16°
Minimal measuring distance*	200 mm	200 mm	200 mm	200 mm	200 mm	200 mm	200 mm

- \* Under reference conditions described in the 3<sup>rd</sup> chapter. L<sub>MIN</sub> is according to the drawings

ALUMINIUM HOUSING, 1½" ANTENNA WITH PLASTIC ENCLOSURE WES-140-□, WGS-140-□ + WAP-140-0, WAP-14N-0		PLASTIC HOUSING, 1½" PP ENCAPSULATED ANTENNA WEP-140-□, WGP-140-□ WEP-14N-□, WGP-14N-□		ALUMINIUM HOUSING, 2" ANTENNA WITH PLASTIC ENCLOSURE WES-150-□, WGS-150-□ + WAP-150-0, WAP-15N-0		PLASTIC HOUSING, 2" PP ENCAPSULATED PLASTIC ANTENNA WEP-150-□, WGP-150-□ WEP-15N-□, WGP-15N-□	
Material of wetted parts	PP	PP	PP	PP	PP	PP	PP
Process connection	1½" BSP, 1½" NPT	1½" BSP, 1½" NPT	2" BSP, 2" NPT	2" BSP, 2" NPT	2" BSP, 2" NPT	2" BSP, 2" NPT	2" BSP, 2" NPT
Minimal measuring distance*	300 mm	300 mm	300 mm	300 mm	300 mm	300 mm	300 mm

\* Under reference conditions described in the 3<sup>rd</sup> chapter. L<sub>MIN</sub> is according to the drawings

<b>INTEGRATED PLASTIC HOUSING, 1½" HORN ANTENNA WPM-140-□, WPM-14N-□</b>		<b>INTEGRATED PLASTIC HOUSING, 2" HORN ANTENNA WPM-150-□, WPM-15N-□</b>		<b>INTEGRATED PLASTIC HOUSING, 1½" PP ENCAPSULATED ANTENNA WPP-140-□, WPP-14N-□</b>		<b>INTEGRATED PLASTIC HOUSING, 2" PP ENCAPSULATED ANTENNA WPP-150-□, WPP-15N-□</b>	
Material of wetted parts	1.4571, PTFE, PP	PP		1.4571, PTFE, PP		PP	
Process connection	1½" BSP, 1½" NPT	2" BSP, 2" NPT		1½" BSP, 1½" NPT		2" BSP, 2" NPT	
Beam angle (-3dB)	19°	16°					
Minimal measuring distance*	200 mm	200 mm		300 mm		300 mm	

\* Under reference conditions described in the 3<sup>rd</sup> chapter. L<sub>min</sub> is according to the drawings

<b>ALUMINIUM HOUSING, 2" TRICLAMP ANTENNA WITH PTFE ENCLOSURE, HYGIENIC VERSION WES-140-□, WGS-140-□ + WAT-14T-0</b>		<b>PLASTIC HOUSING, 2" TRICLAMP ANTENNA WITH PTFE ENCLOSURE, HYGIENIC VERSION WEM-140-□, WGM-140-□ + WAT-14T-0</b>		<b>ALUMINIUM HOUSING, DN50 PIPE COUPLING ANTENNA WITH PTFE ENCLOSURE, HYGIENIC VERSION WES-140-□, WGS-140-□ + WAT-14R-0</b>		<b>PLASTIC HOUSING, DN50 PIPE COUPLING ANTENNA WITH PTFE ENCLOSURE, HYGIENIC VERSION WEM-140-□, WGM-140-□ + WAT-14R-0</b>	
Material of wetted parts	1.4571, PTFE	1.4571, PTFE	1.4571, PTFE	1.4571, PTFE	1.4571, PTFE	1.4571, PTFE	1.4571, PTFE
Process connection	2" TRICLAMP	2" TRICLAMP	2" TRICLAMP	DN50 MILCH	DN50 MILCH	DN50 MILCH	DN50 MILCH
Minimal measuring distance*	300 mm	300 mm	300 mm	300 mm	300 mm	300 mm	300 mm

\* Under reference conditions described in the 3<sup>rd</sup> chapter. L<sub>MIN</sub> is according to the drawings

**ALUMINIUM HOUSING,  
HORN ANTENNA WITH FLANGE  
WES-18□-□, WGS-18□-□**

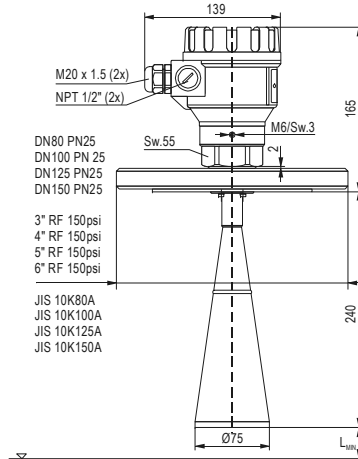

Material of wetted parts	1.4571, PTFE
Process connection	Flange
Beam angle (-3dB)	11°
Minimal measuring distance*	200 mm

\* Under reference conditions described in the 3<sup>rd</sup> chapter. L<sub>MIN</sub> is according to the drawings

<p><b>HIGH TEMPERATURE VERSION, ALUMINIUM HOUSING, 1½" HORN ANTENNA</b> WHS-140-□, WJS-140-□, WHS-14N-□, WJS-14N-□</p>	<p><b>HIGH TEMPERATURE VERSION, ALUMINIUM HOUSING, 2" HORN ANTENNA</b> WHS-150-□, WJS-150-□, WHS-15N-□, WJS-15N-□</p>	<p><b>HIGH TEMPERATURE VERSION, ALUMINIUM HOUSING, HORN ANTENNA WITH FLANGE</b> WHS-18□-□, WJS-18□-□</p>	<p><b>HIGH TEMPERATURE VERSION, ALUMINIUM HOUSING, 2" TRICLAMP ANTENNA WITH PTFE ENCLOSURE, HYGIENIC VERSION</b> WHS-140-□, WJS-140-□ + WAT-14T-0</p>	
Material of wetted parts	1.4571, PTFE	1.4571, PTFE	1.4571, PTFE	1.4571, PTFE
Process connection	1½" BSP, 1½" NPT	2" BSP, 2"NPT	Flange	2" TRICLAMP
Beam angle (-3dB)	19°	16°	11°	
Minimal measuring distance*	200 mm	200 mm	200 mm	300 mm

\* Under reference conditions described in the 3<sup>rd</sup> chapter. L<sub>min</sub> is according to the drawings

### 3.2.1. DETERMINE THE MAXIMAL MEASURING RANGE

The maximal measuring range of the PiloTREK radars is significantly depending on the circumstances of the application environment and on the selected device type. Depending on the relative dielectric constant of the measuring medium and the process conditions the maximal measurement range (achievable under the reference conditions) may decrease by even 85% (reduce about to one-sixth!).

The maximal measuring distance is illustrated in the diagram on the right in case of materials with different relative dielectric constant. The diagram is valid for horn antenna without plastic enclosure, for liquids with still surface not tending to foaming, vapouring or steaming and in case of ideally slow (<5m/h) rate of level change.

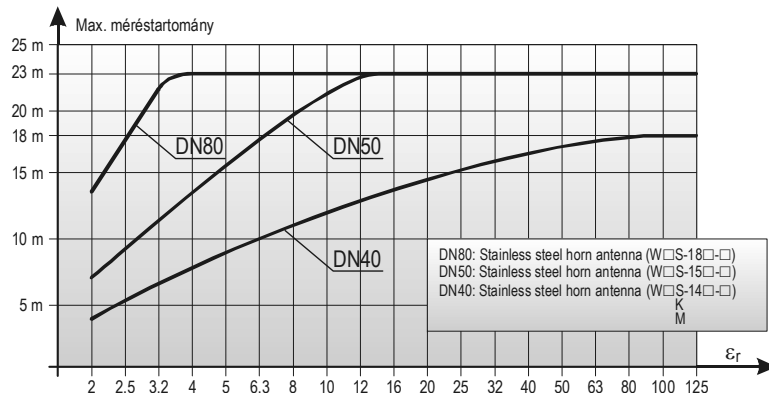

Depending on the process conditions or the plastic antenna enclosure the following typical reducing factors are recommended to be considered in order to calculate the maximal measuring range. When more then one reducing factors occur at the same time then all the factors should be considered for the calculation:

Process Condition	Reflection reduction in Amplitude	Max. measuring distance decrease by	Reducing Factor
Slow mixing or slightly waving	2...6 dB	20-50%	0.8...0.5
Foaming	2...6 dB	20-50%	0.8...0.5
Fast mixing, vortex	8...10 dB	60-70% (the measurement might be completely terminated)	0.4...0.3
Steaming, condensation	3...10 dB	30-70% (the measurement might be completely terminated)	0.7...0.3
PP antenna enclosure	2 dB	20%	0.8
PTFE antenna enclosure	1 dB	10%	0.9

For example: Measurement medium is Styrene ( $\epsilon_r=2.4$ ) at 25°C process temperature and slowly mixed. The device type is WGS-150-4 with WAT-150-0 antenna enclosure. The maximal measuring range is  $(9 \text{ m} * 0.5 * 0.9) = 4 \text{ m}$ .

### 3.3. ACCESSORIES

- User's and Programming Manual
- Warrant Card
- Declaration of Conformity
- 2 pcs M20x1.5 cable glands
- Sealing (Klinger® Oilit) only for BSP threaded process connections

### 3.4. CONDITIONS OF SAFE OPERATION

To avoid the danger of electrostatic charge accumulation, in case of the **WOP**, **WOM** types (with plastic electronic housing or plastic antenna enclosure) the following safety rule shall be observed:

- The measured medium should be an electrostatic conductor, and the electrical resistivity of the measured medium cannot exceed  $10^4 \Omega$ .
- The speed and the method of the filling and emptying process should be chosen properly according to the measured medium.
- The material of the plastic antenna enclosures can produce static electricity. The antenna enclosure is allowed to clean only with wet rag.

#### **Meeting the requirements of the technological process**

Please carefully consider that all parts of the instrument which possible to come into contact with the measured medium – including the transducer, the sealing and any other mechanical parts – should meet all requirements of the applied technological process, such as the process pressure, temperature and chemical effects of the used technologies.

#### **FCC Radio license**

This device complies with Part 15 of the FCC Rules. Operation is subject to the following two conditions:

- (1) This device may not cause harmful interference, and
- (2) this device must accept any interference received, including interference that may cause undesired operation.

**Changes or modifications not expressly approved by the manufacturer could void the user's authority to operate the equipment.**

### 3.5. REPAIR AND MAINTENANCE

The PiloTREK does not require maintenance on a regular basis.

Repairs during or after the warranty period are carried out exclusively at the Manufacturer.

The equipment sent back for repairs should be cleaned or neutralised (disinfected) by the User!



## 4. INSTALLATION

### 4.1. MOUNTING

When choosing the installation place please ensure proper space for later calibrations, verification or maintenance service.

#### PLACEMENT

The ideal position for the PiloTREK is on the  $r = (0.3 \dots 0.5) R$  (in case of cylindrical tank).

It is highly recommended to consider the beam cone on the 2<sup>nd</sup> page drawing. The distance between the sensor and the tank wall should be at least 200 mm. If the unit is installed into dome top or spherical tank, unwanted multiple reflections may appear, which can cancel each other and the measuring signal out, this way it can interfere the measurement.

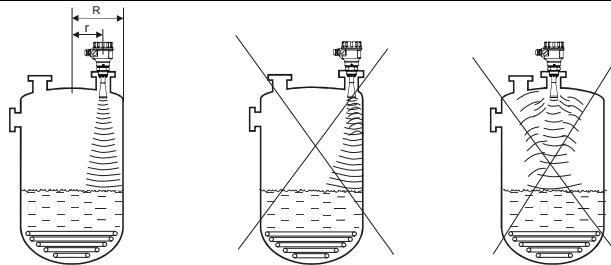

#### MOVING LIQUID SURFACE

Waving, vortex or strong vibration effects can have negative influence on the measurement accuracy and the maximal measuring range. To avoid these effects, the mounting placement should be as far as possible from the sources of these disturbing effects. According to measurement experiences the maximal measuring distance may decrease by 50-70% when the liquid surface is vortexing (see chapter 3.2). For this reason the device should be mounted as far as possible from the filling stream or the tank outlet.

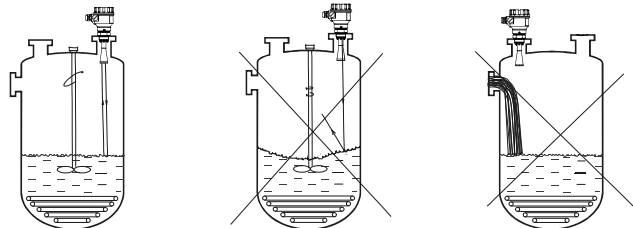

#### FOAMING

Filling, stirring or any other processes in the tank can generate dense foams on the liquid surface, which may considerably damp the reflected signals.

According to measurement experiences, in these cases the maximal measuring distance decreases at least approximately by 50%.

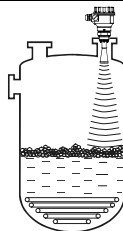

#### FUMES, VAPOURS

If the measured medium or its foam can reach the antenna or the measured medium is highly fuming, these cases build-ups can form on the sensor, which may result in unreliable level measurement.

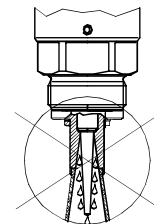

### SENSOR ALIGNMENT

The antenna face should be parallel to the medium surface within  $\pm 2-3^\circ$ .

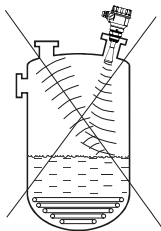

### TEMPERATURE

To avoid overheating the instrument should be protected against direct sunshine.

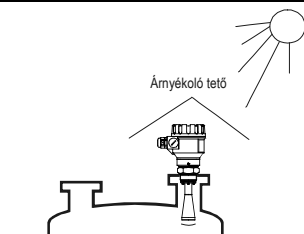

### OBSTACLES

Prior to the installation make sure that no objects (cooling pipes, bracing elements, thermometers, etc.) cross the microwave signals. Especially in case of extraordinary large silos bracing elements and other structural obstacles may cause false reflections which can be damped in most cases: a small bent metal deflector plate mounted above the obstacle can disperse the microwave signals and eliminates the false reflections which disturb the reliable measurement.

If there is no possible mechanical solution to avoid these kinds of false reflections, the programming of the instrument allows blocking out the obstacles. (see: 5.3.4.5)

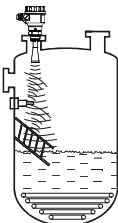

### POLARIZATION PLANE

The emitted radar impulses of PiloTREK are electromagnetic waves. The orientation of the polarization plane is the same as for the electric wave component of the electromagnetic wave. The rotation of the polarization plane compared to the tank position could be useful (for example to avoid disturbing reflections) in certain applications. To rotate the polarization plane loosen the M6 hex socket set screw above the process connection and rotate the instrument. Then tighten the unit by the screw.

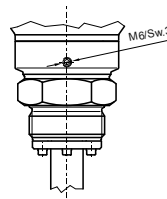

### EMPTY TANK

Especially in case of standing tanks with hemispherical bottom and in case of tanks which have any equipment inside at the bottom (e.g. heating element, stirrer) wrong level measurement may happen when the tank is totally emptied. The reason for this measurement error is that the tank bottom or the objects at the bottom disperse or reflect the emitted microwave signals. Furthermore the lower signal-level dispersed radar impulses may interfere with itself inside the tank.

In order to perform reliable level measurement there should be at least 100 mm liquid level above the disturbing objects at the bottom or above the hemispherical tank bottom.

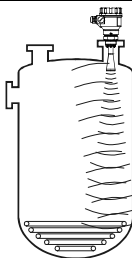

### SOCKET, NOZZLE

The process connection should be implemented that the antenna end should protrude at least 10 mm out of the socket.

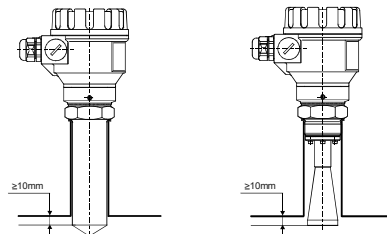

## 4.2. WIRING

The instrument operates from 20 ... 36 V galvanic isolated and not grounded DC power supply in two-wire system. (For Ex version: 20 ... 30 V DC!)

The voltage value measured on the terminal of the instrument should be minimum 20 V (in case of 4mA)! In case of using HART interface – to achieve proper communication between the transmitter's interface and the power-supply – a minimal 250 Ohm resistance should be maintained within the network. The instrument should be wired with shielded cable led through the cable gland. The wiring of the cables can be done after removing the cover of the instrument and the SAP display unit.

**IMPORTANT:** The grounding screw on the housing of the transmitter should be connected to the equipotential network. Resistance of the EP network should be  $R \leq 2$  Ohm measured from the neutral point. Shielding of the cable should be grounded at the control room side to the EP network. To avoid disturbing noises, keep away of closeness to high-voltage cables. Especially the inductive couplings of AC harmonics can be critical (which are present at frequency converter control) because even cable shielding does not supply effective protection against these cases.



The instrument may be damaged by electrostatic discharge (ESD) via its terminal, thus apply the precautions commonly used to avoid electrostatic discharge e.g. by touching a properly grounded point before removing the cover of the enclosure. A possible electrostatic discharge can cause damage for the instrument. Do not touch the internal terminals!

### WATER / VAPOUR

To achieve suitable ingress protection NIVELCO recommends using the suggested cable outer diameter (see technical data table in the 3<sup>rd</sup> chapter) and fasten properly the cable gland.

NIVELCO also recommends leading the connecting cables downwards to lead aside the rain water and the condensed water. This is needed in case of outside installations and some special applications where there is very high humidity or the possibility of water condensation is quite high (for example in cleaning, purification processes, in cooled and / or heated tanks).

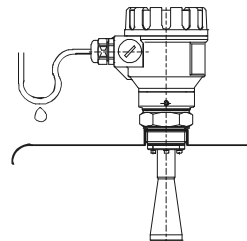
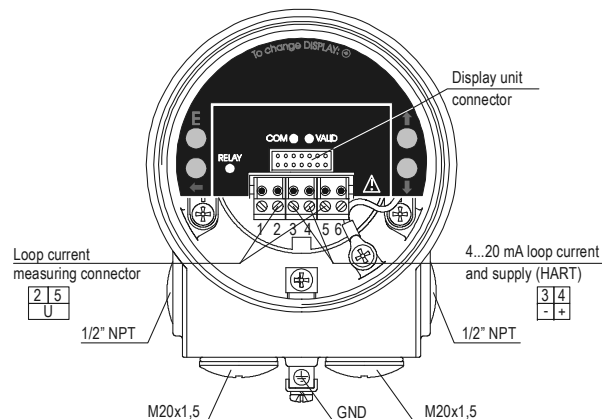

## 4.2.1. WIRING OF THE DEVICES

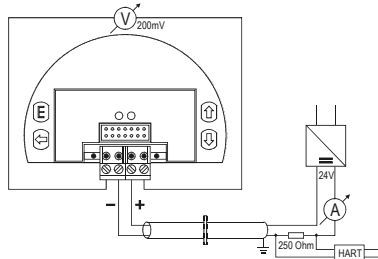

Using HART communication  
in non-Ex environment

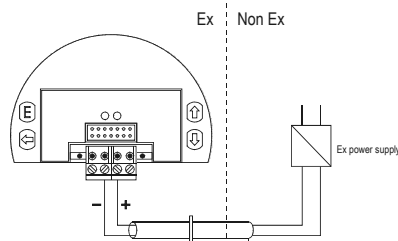

Using Ex approved instrument  
in hazardous environment

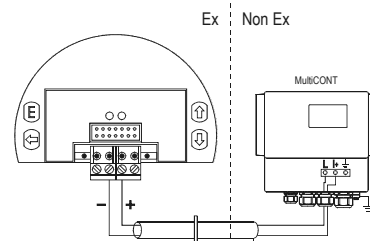

Using MultiCONT process controller  
with Ex approved instrument  
in hazardous environment

### In case of integrated version:

Prior to wiring ensure that the power supply is turned off at the source.  
(For wiring the unit 6 x 0.5 mm<sup>2</sup> cross section or greater cable is recommended).

The necessary programming can be made after energizing the unit.

### Colour codes of the wires:

Green	-	(+)	Positive point of current loop measurement
Yellow	-	(-)	Negative point of current loop measurement
White	-	I (-)	Negative point of current loop, power supply and HART
Brown	-	I (+)	Positive point of current loop, power supply and HART
Green/Yellow	-	<b>GND</b>	Grounding and shielding point

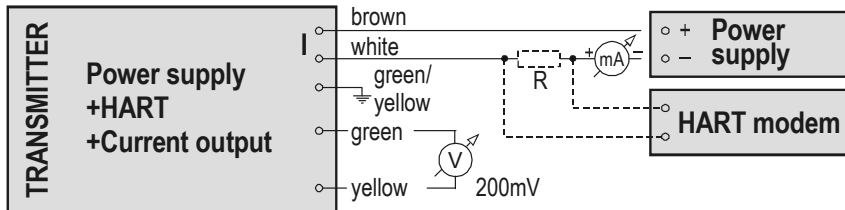
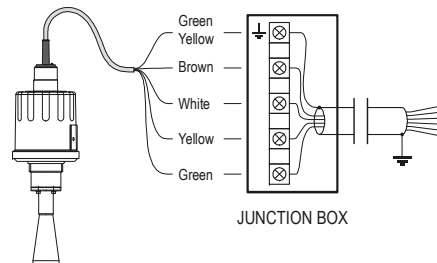

### Extension of the integrated cable:

The usage of a junction box is recommended for extending the cable.

The shielding of the two cables should be connected and grounded at the signal processing device.

## 4.2.2. DETERMIN THE APPROPRIATE POWER SUPPLY VOLTAGE

The minimal power supply voltage required by the PiloTREK devices is depending on the load impedance in accordance to the below diagram:

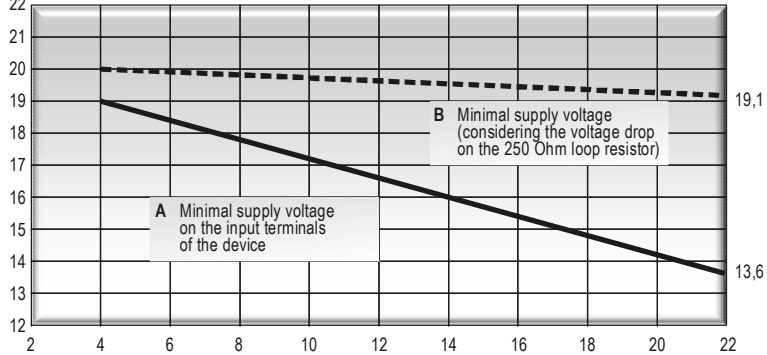

**A:** minimal supply voltage on the input terminals of the device

**B:** minimal supply voltage (considering the voltage drop on the 250 Ohm loop resistor)

Calculation example: Voltage drop calculated with 22 mA:

$$\begin{aligned}U_{\text{minimal supply voltage (22 mA)}} &= 22 \text{ mA} \times \text{load resistance} + U_{\text{input minimum (22 mA)}} \\U_{\text{minimal supply voltage (22 mA)}} &= 22 \text{ mA} \times 250 \text{ Ohm} + 9 \text{ V} = 5.5 \text{ V} + 13.6 \text{ V} = 19.1 \text{ V}\end{aligned}$$

In order to provide operation in the total current loop range the calculation should be also checked with 4 mA:

$$\begin{aligned}U_{\text{minimal supply voltage (4 mA)}} &= 4 \text{ mA} \times \text{load resistance} + U_{\text{input minimum (4 mA)}} \\U_{\text{minimal supply voltage (4 mA)}} &= 4 \text{ mA} \times 250 \text{ Ohm} + 19 \text{ V} = 1 \text{ V} + 19 \text{ V} = 20 \text{ V}\end{aligned}$$

Therefore in case of 250 Ohm load resistance 20 V power supply voltage is just enough for the total 4-20 mA measuring range.

## 4.3. LOOP CURRENT CHECKING WITH HAND INSTRUMENT

After removing the cover and the Display Module, the actual loop current can be measured throughout an internal 1 Ohm shunt resistor by connecting a voltmeter (in the range of 200 mV) to the points 2 and 5 indicated on the wiring drawing above (see 4.2.1).

## 5. PROGRAMMING

The PiloTREK transmitters can be programmed (basically) with the following two ways:

- **Programming with the SAP-300 display unit** (see 5.2)  
All features of the unit can be accessed and all parameters can be set, such as measurement configuration and optimisation, outputs, dimensions for 11 tanks with different shape, 99-point linearization.
- **Programming with MultiCONT process controller or EView2 PC configuration software**

The PiloTREK WGI□ and WJ□ types include the SAP-300 display unit.

The PiloTREK transmitters are fully operational without the SAP-300 display as well, it is only needed for local programming and / or local measurement displaying.

### FACTORY DEFAULT SETTING

The PiloTREK W-100 series level transmitters are factory programmed by the following way:

- ⇒ Measurement mode: Level (LEV). The displayed value is the measured level.
- ⇒ The current output and the bargraph on the right are proportional to the measured level.
- ⇒ 4 mA and 0% are assigned to zero level.
- ⇒ 20 mA and 100% are assigned to the maximal level.
- ⇒ Error indication by the current output: holding the last value.
- ⇒ Level tracking time constant: 15 sec.

The instrument regards the distance (DIST) measured from the antenna end as the basic measurement value. This distance is handled and display in one of the selected dimensions: m, cm, mm, feet, or inch. Since the maximal measurement distance is given (entered in P04) the instrument can calculate the actual level (LEV) value. If the proper mechanical dimensions of the mounting – distance between the sealing and the tank bottom – is known, the measured level values can be more accurate by adding this data. The level values calculated that way are the base for volume (VOL) calculation and the 99-point linearization table (VMT) also uses these values as input data.

## 5.1. THE SAP-300 DISPLAY UNIT

### 5.1.1. PRIMARY MEASUREMENT SCREEN

The SAP-300 is a 64x128 dot-matrix LCD display which can be plugged into the transmitter. (It is universal – usable in other NIVELCO devices as well – provided that the system software supports SAP-300.)

#### **Warning!**

The SAP-300 module is based on LCD technology, so please make sure it is not exposed to permanent heat or direct sunlight, in order to avoid damage of the display unit. If the instrument cannot be protected against direct sunlight or high temperature that is beyond the standard operating temperature range of the SAP-300, please do not leave the SAP display in the instrument.



Measurement displaying with the SAP-300 display unit

#### Elements of the displaying:

1. Primary (Measured) Value (PV), in accordance to BASIC SETUP / PV. MODE.
2. Calculation mode of Primary Value (PV), in accordance to BASIC SETUP / PV. MODE.
3. Type and value of the initial quantity used for calculating the Primary Value (PV):
  - in case of Level measurement (LEV) it is Distance (DIST),
  - in case of Volume measurement (VOL) it is Level (LEV).
4. Trend direction arrows. The empty triangle shows when the change of the measured value is small, the filled triangle shows large-scale change. If none of the arrows are shown the measured value is constant.
5. Measured PV (Distance Value) in relation to measurement range (Sensor range) displayed in a bargraph.
6. Indication of Primary Value simulation. In this case the display and output show the values of the simulation and not the measured values.
7. Indication of active (Volume / Mass Table - VMT) calculation mode.

During active simulation the critical measurement errors will be displayed to give information to the user.

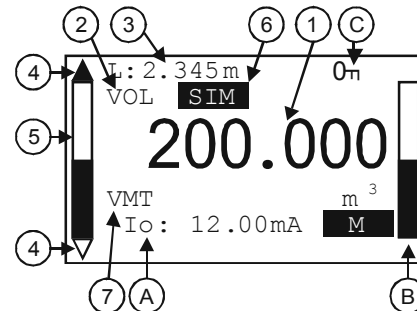

#### A. Calculated value of the output current.

After the dimension, the mode of current output is indicated by inverse inscription:

**M**

Manual mode (see 5.3.2.1)

**H**

HART address is not 0, so output current has become overwritten to 4 mA (see 5.3.2.1)

**E !**

Analogue transmission reacts to a programmed failure condition if an upper or lower fault current is programmed (see 5.3.2.4)

#### B. Output range (4-20 mA) indicated in a bargraph.

The bottom of the bargraph is assigned to 4 mA and the top is assigned to 20 mA.

#### C. Indication of Menu Lock:

- If key symbol is visible, the unit is protected with a password. When entering the menu, the instrument asks for the correct password (see 5.3.6.1).
- If REM message is visible, the instrument is in remote programming mode and the main menu cannot be accessed.

Errors occurred during the measurement can be seen at the bottom line of the display.



## 5.1.2. INFORMATION SCREENS

Press  $\downarrow$  button to cycle between the main measurement screen and the information display screen:

1. General information screen (DEV. INFO)
  - Overall running time (OV. RUN TIME)
  - Run time after power on (RUN TIME)
  - Type of interface (INTERFACE) in the instrument.
  - Type of the instrument (TYPE)

2. Sensor information screen: (SENSOR INFO)
  - Number of echoes (ECHO TOT/SEL)
  - Blocking (BLOCKING)
  - Signal-to-noise ratio (SN)
  - Temperature (TEMP)

3. Echo table: (ECHO TABLE)

The location (distance) and the amplitude of the echoes (Dist. / Amp.) are listed

The listed items are the reflections detected by the PiloTREK (measured in dB) and the approximate distance from the process connection. The listed values are not accurate measurement values, since around the selected echo (measurement window) there are further measurements and signal processing procedures in order to provide accurate measurement display and level transmission.

The informative screen returns back to main screen after 30 seconds.

By pressing the  $\uparrow$  button the user can return to the main screen any time.

Pressing the  $\text{E}$  button in any of the screens the user can enter the main menu.

After exiting the menu always the main screen will be shown.

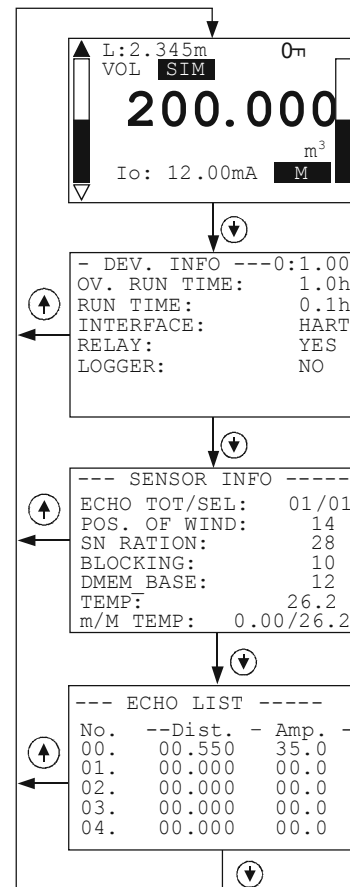



### 5.1.3. ECHO MAP

Pressing the  button in the measurement screen the echo map screen will appear. This screen shows the following information:

1. Echo diagram
2. Actual measured distance
3. Maximal measuring range

The echo map screen returns back to main screen after 30 seconds.

By pressing the  button the user can return to the main screen any time. Pressing the  button in any of the screens the user can enter main menu. After exiting the menu always the main screen will be shown.

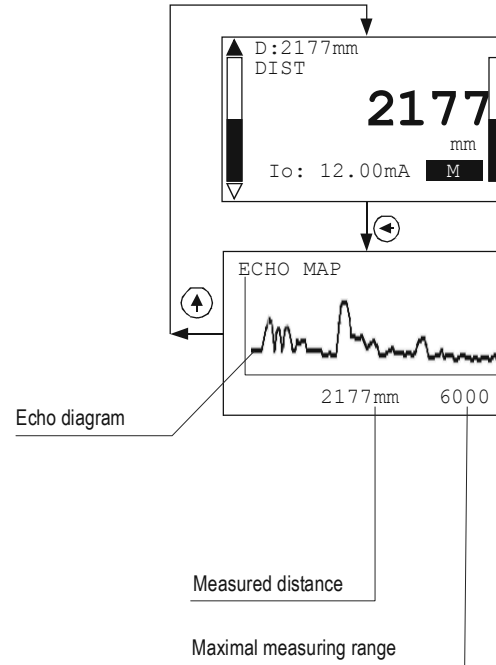

## 5.2. PROGRAMMING WITH THE SAP-300 DISPLAY MODULE

When entering the menu the instrument makes a copy of the actual parameters and all changes are done to this duplicated parameter set. During programming the instrument keeps measuring and transmitting with the current (and intact) parameter set. After exiting the menu the instrument replaces the original parameters with the new parameter set and will measure according to the new parameters. This means that the change of the parameters does not become immediately effective when pressing the  $\text{E}$  button!

Entering the menu can be done by pressing the  $\text{E}$  button, while exiting the menu can be done by pressing the  $\leftarrow$  button.

If the instrument is left in programming mode after 30 minutes it will automatically return to measuring mode. If the SAP-300 display is removed during programming the instrument immediately returns to measuring mode.

As programming with SAP-300 (manual programming) and HART (remote mode) programming is not possible at the same time, only one programming method could be chosen. Measured values can be read out through HART at any time.

### 5.2.1. COMPONENTS OF THE PROGRAMMING INTERFACE

The parameters of the instrument are grouped according to their functions. The programming interface consists of lists, dialog windows, edit windows and report windows.

#### Lists

Navigation between the lines of a list can be done by pressing the  $\uparrow$  /  $\downarrow$  buttons. Pressing the  $\text{E}$  button activates a list item. The selected list item is marked with inverse colour. Exit from a list by pressing the  $\leftarrow$  button.

#### Menu list

The Menu list is a specialized list. Its characteristic is that upon selecting a list item we directly get into another list, and these lists are opening from each other in different levels.

The menu header (1) helps to navigate.

Entering the main menu can be done by pressing the  $\text{E}$  button. Navigation between the menu items can be done by pressing the  $\uparrow$  /  $\downarrow$  buttons. Enter to the selected menu by pressing the  $\text{E}$  button. The selected list item is marked with inverse colour.

Exit from a submenu by pressing the  $\leftarrow$  button. Pressing the  $\leftarrow$  button in the main menu will quit from the programming mode and the instrument will return to measuring mode.

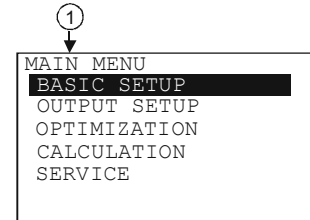

## Dialog window

During the programming the system sends messages or warnings to the users by dialog windows. These usually can be acknowledged by pressing the  $\leftarrow$  button or the user can choose between two options (usually YES or NO) by pressing the  $\uparrow$  /  $\downarrow$  buttons. In some cases one of the parameters has to be changed to correct an error.

## Edit window

An edit window is used for modifying a numeric parameter value. The selected character can be changed by pressing the  $\uparrow$  /  $\downarrow$  buttons. The cursor can be moved to left, by pressing the  $\leftarrow$  button.

The direction of the cursor movement through the digits is right to left. The changed value can be validated by pressing the  $\text{E}$  button. The software checks if the entered value is appropriate, exiting from the edit window is only possible after entering a correct value. If the entered value is uninterpretable the software sends an error message in the bottom line (1) of the display.

## Edit window – button combinations

In the edit window the following button combinations are available:

1. Recalling the parameters to the state before editing ( $\leftarrow$  +  $\uparrow$ , pressed for 3 sec.)
2. Recalling default parameters ( $\leftarrow$  +  $\downarrow$ , pressed for 3 sec.)
3. Inserting (currently) measured value to the edit window ( $\uparrow$  +  $\downarrow$ , pressed for 3 sec.)  
Only for certain parameters!

## 5.2.2. MENU STRUCTURE

### Main menu

BASIC SETUP	Parameter group of the basic measurement parameters
OUTPUT SETUP	Parameter group of the output parameters
OPTIMIZATION	Parameter group for measurement optimization settings
CALCULATION	Calculations
SERVICE	Service functions, calibration, test and simulation

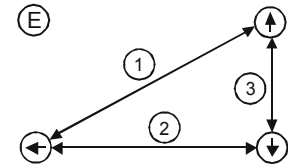
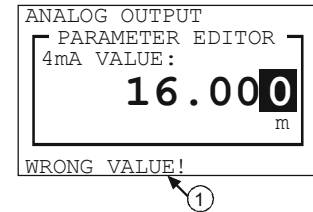
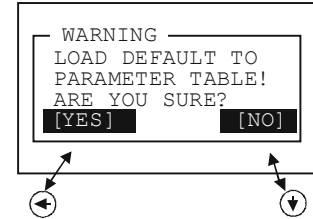

## 5.3. PROGRAMMABLE FEATURES DESCRIPTION

### 5.3.1. BASIC MEASUREMENT SETTINGS

#### 5.3.1.1 Default unit system

Parameter:	P00: c, where c: 0, 1.	Default value:	EU
Path:	BASIC SETUP / UNITS / ENGINEERING SYSTEM		
Description:	This should be configured as the first step of the programming. Here you can choose the default unit system: <ul style="list-style-type: none"><li>• EU European unit system</li><li>• US Anglo-Saxon / American unit system</li></ul>		

#### 5.3.1.2 Dimension of the default unit system

Parameter:	P00:b, and P02:b, or P02:c	Default value:	mm, m <sup>3</sup> , t
Path:	BASIC SETUP / UNITS / ENGINEERING UNITS		
Description:	The dimension of the selected default unit system can be specified in this menu. The selected measurement mode here will define the primary measured value and the displayed value, furthermore it will be the source for the current output: <ul style="list-style-type: none"><li>• BASIC UNITS (m, cm, mm, ft, inch )</li><li>• VOLUME / FLOW UNITS (m<sup>3</sup>, l, ft<sup>3</sup>, gallon )</li><li>• MASS UNITS (t, t)</li></ul>		

If the dimension is modified, the device resets all the parameters after a warning message.

#### 5.3.1.3 Primary Value Mode

Parameter:	P01: b a	Default value:	DIST
Path:	BASIC SETUP / PV MODE		
Description:	This mode determines the primary value and the displayed value. It also determines the value which will be proportional to the output current. <ul style="list-style-type: none"><li>• DISTANCE</li><li>• LEVEL</li><li>• VOLUME</li><li>• MASS</li></ul>		

#### 5.3.1.4 Maximal Measuring Distance

Parameter:	P04	Default value:	
Path:	BASIC SETUP / MAX. MEAS.DIST		
Description:	This parameter should be entered all the cases, except distance measurement mode. But it is suggested to be programmed in case of distance measurements in order to avoid the disturbing effects of possible unwanted multiple reflections!		

#### 5.3.1.5 Damping Time

Parameter:	P20	Default value:	15 sec
Path:	BASIC SETUP / DAMPING TIME		
Description:	Damping time is used to damp the unwanted fluctuations of the output and display. If the measured value changes rapidly the new value will settle with 1% accuracy after this set time. (Damping is according to the exponential function).		

#### 5.3.1.6 Demo Mode

Parameter:	P00: d	Default value:	OFF
Path:	BASIC SETUP / DEMO MODE		
Description:	<ul style="list-style-type: none"><li>• OFF: The operation is performed with considering all the application parameters (such as filling, emptying speed, echo selection, etc..)</li><li>• ON: This fast operation mode ignores the application parameters. The demo mode uses a fast algorithm evaluation independently from P25, P26 and P27 parameters. The measurement accuracy and reliable operation between process environments are not guaranteed!</li></ul>		

### 5.3.2. ANALOGUE OUTPUT

#### 5.3.2.1 Output Current Mode

Parameter:	P12:b, where b: 0, 1.	Default value:	AUTO
Path:	OUTPUT SETUP / ANALOG OUTPUT / CURRENT MODE		
Description:	Transmission mode of the current output. <ul style="list-style-type: none"><li>• AUTO The output current is calculated from the measured value, output is active.</li><li>• MANUAL The output current is fixed at a constant (set) value (see: 5.3.2.5). In this mode the setting of the error current is irrelevant. The set (current) value overwrites the 4mA output of HART multidrop mode!</li></ul>		

### 5.3.2.2 Output Current Value assigned to 4 mA

Parameter: P10 Default value: 0 mm  
Path: OUTPUT SETUP / ANALOG OUTPUT / 4mA VALUE  
Description: Measured value assigned to 4 mA current value.  
The transmitted value is in accordance to the primary value (PV) (P01:a). Assignment can be done that the change in measured value and the change in the output value are the same (normal), or opposite directional (inverse operation). For example: 1m level is 4 mA, 10m level is 20 mA, or 1m level is 20 mA and 10m level is 4 mA.

### 5.3.2.3 Output Current Value assigned to 20 mA

Parameter: P11 Default value: Maximal measurement range (mm)  
Path: OUTPUT SETUP / ANALOG OUTPUT / 20mA VALUE  
Description: Measured value assigned to 20 mA current value.  
The transmitted value is in accordance to the primary value (PV) (P01: a). Assignment can be done that the change in measured value and the change in the output value are the same (normal), or opposite directional (inverse operation). For example: 1m level is 4 mA, 10m level is 20 mA, or 1m level is 20 mA and 10m level is 4 mA.

### 5.3.2.4 Output Current Error Mode

Parameter: P12:a, ahol a: 0, 1, 2 Default value: HOLD  
Path: OUTPUT SETUP / ANALOG OUTPUT / ERROR MODE  
Description: Error indication by the current output:

- HOLD Error indication has no effect on the output current.
- 3.8mA Error indication: the output current gets 3.8mA.
- 22mA Error indication: the output current gets 22mA.

**Warning:** This error indication is active unless the failure is fixed, or until the failure terminates.

### 5.3.2.5 Fixed Output Current

Parameter: P08 Default value: 4 mA  
Path: OUTPUT SETUP / ANALOG OUTPUT / MANUAL VALUE  
Description: Parameter for setting the fixed output current:  
Values between 3.8 and 20.5 can be entered. The output current will be set to the entered value and analogue transmission will be suspended (see: 5.3.2.1). This error indication overrides all other error indication.

### 5.3.3. DIGITAL OUTPUT

#### 5.3.3.1 HART Polling Address

Parameter:	P19	Default value:	0
Path:	OUTPUT SETUP / SERIAL OUTPUT / ADDRESS		
Description:	HART Polling Address The polling address can be set between 0 and 15. For a single instrument the polling address is 0 and the output is 4-20 mA (analogue output). If multiple units are used in HART Multidrop mode (max. 15 pcs.) the polling addresses should differ from 0 (1-15), in this case the output current will be fixed at 4 mA.		

### 5.3.4. MEASUREMENT OPTIMIZATION

#### 5.3.4.1 Blocking, Dead Zone

Parameter:	P05	Default value:	300 mm
Path:	OPTIMIZATION / DEAD ZONE		
Description:	The instrument ignores all reflections within the dead zone and the close-end blocking distance. The disturbing objects and false reflections which are close to the sensor can be eliminated by entering the dead zone value manually.		

#### 5.3.4.2 Echo Selection

Parameter:	P25:a, where a: 0, 1, 2, 3	Default value:	AUTO
Path:	OPTIMIZATION / ECHO SELECTION		
Description:	Selection of Echo within the measuring window. In order to avoid disturbing reflections the instrument forms a so-called measuring window around the reflected signal. The distance measurement is performed with the echo signal within the measurement window. <ul style="list-style-type: none"><li>• AUTO</li><li>• FIRST</li><li>• HIGHEST AMPLITUDE</li><li>• LAST</li></ul>		

#### 5.3.4.3 Emptying Speed

Parameter:	P27	Default value:	50 m/h
Path:	OPTIMIZATION / EMPTYING SPEED		
Description:	This parameter provides additional protection against echo loss in applications involving very heavy fuming during emptying process. Correct setting increases the reliability of the measurement during the emptying. The parameter must not be smaller than the fastest possible emptying rate of the actual process.		



#### 5.3.4.4 Filling Speed

Parameter: P26  
Path: OPTIMIZATION / FILLING SPEED  
Description: This parameter provides additional protection against echo loss in applications involving very heavy fuming during filling process. Correct setting increases the reliability of the measurement during the filling. The parameter must not be smaller than the fastest possible filling rate of the actual technology.

Default value: 50 m/h

#### 5.3.4.5 Background Image

Parameter: OPTIMIZATION / BACKG.ECHO IMAGE / SAVE BACKG. IMAGE  
Path: The not-moving disturbing objects inside the tank which generates unwanted false reflections can be blocked out from the measurement range. For this purpose the instrument needs to map the totally empty tank to create a "background image". After this procedure the software will automatically recognise and ignore the reflections coming from the disturbing objects crossing the microwave beam (see 4.1 - Obstacles).  
Warning! The background image should be saved only when the tank does not contain measurement medium but the disturbing objects inside the tank are not removed. The background image is not recommended to be saved when the tank is filled with the measurement medium since it might result wrong level measurement.

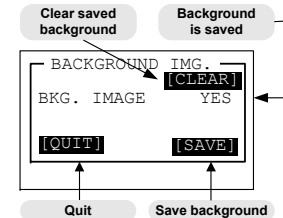

#### 5.3.4.6 Using saved background image

Parameter: P35: a, where a: 0, 1  
Path: OPTIMIZATION / BACKG.ECHO IMAGE / SAVE BACKG: IMAGE  
Description: Turning ON or OFF the usage of saved background image during the calculations as per the above 5.3.4.5 point described.

- OFF: Ignoring the saved background image.
- ON: Saving background image, damping reflections coming from the disturbing objects.

Default value: OFF

#### 5.3.4.7 Threshold value

Parameter: P29  
Path: OPTIMIZATION / TRESHOLD VALUE  
Description: Defining an upper limit value above the saved background image described in 5.3.4.5 point. The instrument will evaluate the measurement result as a real echo when the reflected signal exceeds the saved background level with the threshold value entered here. Setting the threshold value is useful when the level in the tank and the position of the (small surface) not-moving disturbing object are the same. This case the instrument will not regards the echo signal as false reflection.

Default value: 4 dB

## 5.3.5. CALCULATIONS

### 5.3.5.1 Specific gravity

Parameter:	P32	Default value:	0
Path:	CALCULATION / SPECIFIC GRAVITY		
Description:	Entering a value (other than "0") of specific gravity in this parameter, the MASS value will be displayed instead of Volume (VOL) in the dimension of tonne or lb/tonne depending on P00 (c) and P02 (b).		

### 5.3.5.2 Volume / Mass Calculation Mode

Parameter:	P47: a	Default value:	0
Path:	CALCULATION / V/M CALC. MODE		
Description:	Calculation of the volume and mass can be performed with two ways: <ul style="list-style-type: none"><li>• TANK FUNCTION/SHAPE – volume and mass calculation with a tank shape formula. Entering this menu point the table is automatically OFF.</li><li>• V/M TABLE – volume and mass calculation with a table. Entering this menu point the table automatically turns ON.</li></ul>		

### 5.3.5.3 Volume / Mass Table

Parameter:	-
Path:	CALCULATION / V/M CALC. MODE / V/M TABLE
Description:	<ul style="list-style-type: none"><li>• VIEW/EDIT TABLE</li><li>• ADD ITEM</li><li>• DELETE ITEM</li></ul>

If none of the formulas match perfectly to the characteristics of the needed tank, there is a possibility to use table calculation mode. The device can handle a 99-point table on this purpose and counts values between the neighbouring point pairs with linear interpolation.

The input (left) side of the table contains the level data, the output (right) side contains the volume or mass data.

The first point pair of the table should be 0,0. If a long table wanted to be shortened, 0,0 point pair should be entered into the last item of the table and the device modifies the unused point pairs automatically in the background to 0,0. The status (ON or OFF) of the table is shown on a warning message (1) on the bottom line of the display.

All modifications are done on a temporary table. This temporary table becomes valid after exiting.

Modifications during the programming procedure have no effect on the measurement and the transmitting.

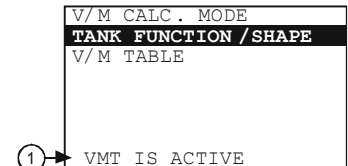

Entering the point pairs can be done in arbitrary order, because the device sorts according to ascending order. Both sides of the table have to be strictly monotonic increasing. In case of any error, warning message (see: 6<sup>th</sup> chapter) will appear. When entering again the table an inscription indicates the first wrong line.

View table:

In VIEW/EDIT TABLE menu point items of the ordered table can be checked. For moving in the list use the  $\blacktriangledown$  and  $\blacktriangleup$  buttons, for editing the selected item use the  $\text{E}$  button. Exiting from the list can be done by pressing the  $\blacktriangleleft$  button.

Edit table:

Adding a point pair (ADD ITEM) to the list or pressing  $\text{E}$  button on an existing item, an edit screen will appear. In this edit screen there are two editing filed. Both editing field works as same as editing a parameter. Getting from the first field to the second field press the  $\text{E}$  button. Pressing  $\text{E}$  button in the second field will return back to the previous menu point. When exiting from the last field, the device performs the ordering of the table.

Delete item

Moving in the list can be done with  $\blacktriangledown$  and  $\blacktriangleup$  buttons, for deleting an item press the  $\text{E}$  button on the selected item. Exiting from the list can be done by pressing the  $\blacktriangleleft$  button. The table should contain at least 2 items.

EDIT/VIEW TABLE	
01:	0000.0 000000.000
02:	0100.0 000100.000

02. VM TABLE ITEM	
LEVEL VALUE :	0012.0 $\text{cm}^3$
V/M VALUE :	095310.000 $\text{m}^3$

DELETE ITEM	
01:	0000.0 000000.000
02:	0100.0 000100.000

### 5.3.5.4 Tank Functions / Shape

Parameter:	P40:a, where a: 0,1, 2, 3, 4.	Default value:	0
Path:	CALCULATION / V/M CALC. MODE / TANK FUNCTION/SHAPE		
Description:	<ul style="list-style-type: none"> <li>• STANDING CYL. - Standing cylindrical tank</li> <li>• STD. CYL. CON. BOT. - Standing cylindrical tank with conical bottom</li> <li>• STD. RECT. W/CHUTE - Standing rectangular tank with or without chute</li> <li>• LYING CYLINDRICAL - Lying cylindrical tank</li> <li>• SPHERICAL - Spherical tank</li> </ul>		

### 5.3.5.5 Tank Bottom Shape

Parameter:	P40:b, where b: 0,1, 2, 3	Default value:	0
Path:	CALCULATION / V/M CALC. MODE / TANK FUNCTION/SHAPE		
Description:	This menu only appears, if it has an importance on the selected tank shape type! <ul style="list-style-type: none"> <li>▪ SHAPE0</li> <li>▪ SHAPE1</li> <li>▪ SHAPE2</li> <li>▪ SHAPE3</li> </ul>		

### 5.3.5.6 Tank Dimensions

Parameter: P41- P45  
 Path: CALCULATION / V/M CALC. MODE / TANK FUNCTION/SHAPE  
 Description:

Default value: 0

- DIM1 (P41)
- DIM2 (P42)
- DIM3 (P43)
- DIM4 (P44)
- DIM5 (P45)

Standing cylindrical tank with hemispherical bottom  $a = 0$

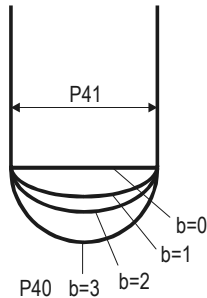

Standing cylindrical tank with conical bottom  $a = 1$  ;  $b = 0$

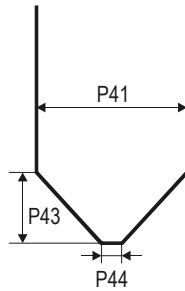

Standing rectangular tank with or without chute  $a = 2$  ;  $b = 1$

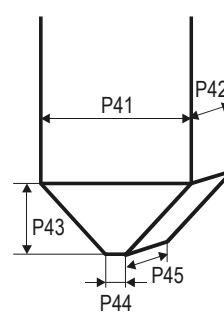

If no chute: P43, P44 and P45 = 0

Lying cylindrical tank  $a = 3$

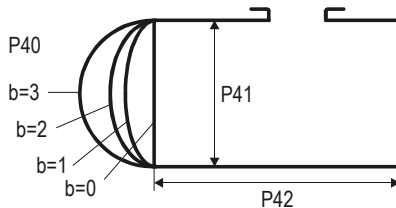

Spherical tank  $a = 4$  ;  $b = 0$

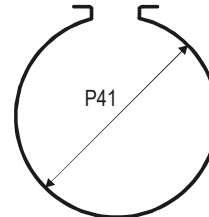

## 5.3.6. SERVICE FUNCTIONS

### 5.3.6.1 Security Codes

#### User codes

Path: SERVICE / SECURITY / USER LOCK

Description: Setting or unlocking the user security code.

The instrument can be protected against unauthorized programming with a 4 digit PIN (Personal Identification Number) code. If either of the digits differs from 0 the code is active. If zero is specified, then the secret code has been deleted!

In case of Active code, this code is requested at menu entry.

#### Service code

Path: SERVICE / SECURITY / SERVICE LOCK

Description: Setting of the service code.

Only for trained personnel!

### 5.3.6.2 Current Output Test

Parameter: P80

Path: SERVICE / OUTPUT TEST / ANALOG OUTPUT / CURRENT VALUE

Description: Loop current test (mA)

Entering this Parameter the current value which is proportional to the actual measurement value will appear on the display and the output. In loop current test mode, values between 3.9 and 20.5 can be entered. The output current will be set to the entered value. The measured current on the output should be equal to the set value.

In test mode a dialog window warns the user of the fixed output current until the user exits the warning message window.

Exiting can be done by pressing the  button.

### 5.3.6.3 Distance Simulation

This function facilitates the user to be able to check the calculations (tank formula, table), outputs, and the additional processing instruments connected to the output. PiloTREK transmitters can perform simulation on the value of a constant or a variable. To start simulation the instrument must return to Measurement mode. In Measurement mode if simulation is in progress, an inverse SIM caption appears on the display.

### **Simulation mode**

Parameter:	P84:a, where a: 0,1, 2, 3, 4	Default value:	OFF
Path:	SERVICE / DIST SIMULATION / MODE		
Description:	Simulation mode: <i>OFF</i> No simulation <i>FIX VALUE</i> Value of the simulated distance is set according to the lowest value of the simulation. <i>MANUAL VALUE</i> . . . . <i>TRIANGLE WAVE</i> Value of the simulated distance changes linearly between the lowest and highest values with an adjustable cycle time.		
	<i>SQUARE WAVE</i> The simulated value jumps between the lowest and highest values with an adjustable cycle time.		

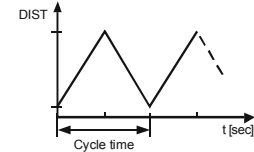

### **Simulation cycle**

Parameter:	P85	Default value:	60 sec
Path:	SERVICE / DIST. SIMULATION / TIME		
Description:	Cycle time of the simulation		

### **Bottom value of the simulation**

Parameter:	P86	Default value:	0 mm
Path:	SERVICE / DIST. SIMULATION / BOTTOM VALUE		
Description:	Lowest value of the simulation		

### **Upper value of the simulation**

Parameter:	P87	Default value:	Programmed measurement range
Path:	SERVICE / SIMULATION / UPPER VALUE		
Description:	Highest value of the simulation		

### **5.3.6.4 Load Default Values**

Path:	SERVICE / DEFAULTS / LOAD DEFAULT
Description:	This command loads all default values of the instrument. After loading the default values the parameters can freely be changed, the effect of the changes does not affect on the measurement until the user exits from the Programming mode and returns to Measurement mode. Before loading the defaults the software asks for a confirmation from the user because all user parameters will be lost!

## 6. ERROR CODES

MESSAGE ON THE SCREEN	ERROR DESCRIPTION	PROCEDURE TO DO	CODE
MEMORY ERROR	Memory error	Contact the service!	1
NO ECHO	Sensor error	Contact the service!	2
EE COM. ERROR	Hardware error (EEPROM communication error)	Contact the service!	3
MATH. OVERLOAD	Calculation overflow	Check the programming!	4
SIGNAL IN N.D.B.	Sensor or calibration error (Measured value is in the close-end dead-zone)	Contact the service!	5
SIGNAL IN F.D.B.	Sensor or calibration error (Measured value is in the far-blocking zone)	Check the installation conditions!	7
VMT SIZE ERROR	Linearization error: Less than two items are in the table.	Check the content of the VMT! See: 5.3.5.3.	12
VMT INPUT ERROR	Linearization table error: monotonicity error in the input (level) side of the table.	Check the content of the VMT! See: 5.3.5.3.	13
VMT OUTPUT ERROR	Linearization table error: monotonicity error in the output (volume or mass) side of the table.	Check the content of the VMT! See: 5.3.5.3.	14
VMT INPUT OV.RNG.	Linearization table error: The measured level is greater than the highest level of the table's input side.	Check the content of the VMT! See: 5.3.5.3. Device performs extrapolation according to the last point pairs!	15
EE CHK ERROR	Parameter checksum error.	Check the programming! For recalculate the checksum modify a parameter and return to Measurement mode. If this error still remains, contact the service!	16
INTEGRITY ERROR	Parameter integrity error (Automatically corrected internal error). Only WARNING message.	Check the programming!	17
AC COM. ERROR	Hardware error	Contact the service!	18
CALIBRATION ERROR	Sensor calibration error	Contact the service!	

## 7. PiloTREK W-100 PARAMETER TABLE

Pxx	Parameter name	d	c	b	a
00	Engineering system, dimensions	DEMO mode 0 = Normal mode 1 = Demo mode	Engineering system: 0 = EU 1 = US	Dimension: (EU) 0 = m, 1 = cm, 2 = mm (US) 0 = ft, 1 = inch	
01	Source of Primary Value (PV)				0 = DIST, 1 = LEVEL, 2 = VOLUME, 3 = MASS
02	Selectable dimensions		Time units: 0= sec 1= min 2= hour 3=day	(VOL/F-EU) 0 = m³, 1=liter (VOL/F-US) 0 = ft³, 1 = US gallon (MASS-EU) 0 = tonne, 1= US tonne (MASS-US) 0 = tonne, 1 =lb(pound)	Temperature unit: 0= °C
04	Max. measuring distance	Maximal measuring distance of the level transmitter can be defined			
05	Blocking / DEAD ZONE	Minimal measuring distance within the ignores all the measurement values			
08	Fix current output	Fix forced value on the output current between 3.8 and 20.5 mA for loop current measuring purposes (operation mode = manual)			
10	4 mA	Measured and transmitted value (PV) assigned to 4 mA current value			
11	20 mA	Measured and transmitted value (PV) assigned to 20 mA current value			
12	Output current mode			Operation mode: 0= AUTO 1= MANUAL	Error indication of the current output: 0= HOLD 1= 3.8mA 2= 22mA
19	HART polling address	HART Short Address of the level transmitter (0-15)			
20	Damping time	Damping time of the accurate transmitted (displayed) value in sec. after a high fluctuation in the measured value (0-999)			
25	Echo selection in the measuring window				0 = AUTO 1= FIRST 2= HIGHEST AMPLITUDE 3= LAST
26	Filling speed	Rate of change of the measured value (when distance is decreasing) which can be just followed with the level transmitter			
27	Emptying speed	Rate of change of the measured value (when distance is increasing) which can be just followed with the level transmitter			
29	Threshold value	Threshold limit value (0 - 6 dB) for the received echo evaluation			



32	<b>Specific gravity of the medium</b>	Data for mass calculation			
35	<b>Background mode</b>				Calculating with the saved background image: 0= OFF 1= ON
40	<b>Tank shape</b>				0 = Standing cylindrical tank with dome bottom 1 = Standing cylindrical tank with conical bottom 2 = Standing rectangular tank with or without chute 3 = Lying cylindrical tank 4 = Spherical tank
41-45	<b>Tank dimensions</b>				
47	<b>VMT mode</b>				<u>Operation of the linearization:</u> 0 = OFF, 1 = ON
60	<b>Overall runtime</b>	Elapsed overall operating hours of the level transmitter (working time) with 0.1 hour accuracy. Service data			
61	<b>Runtime after last reset</b>	Elapsed operating hours of the level transmitter since the last turning ON with 0.1 hour accuracy. Service data			
70	<b>Number of echoes</b>	Service data			
71	<b>Position of the measuring window</b>	Service data			
74	<b>Signal-to-noise ratio</b>	Service data			
75	<b>Blocking distance value</b>	Service data			
80	<b>Current output test</b>	Fix forced value on the output current between 3.8 and 20.5 mA for checking the accuracy of the current generator			
84	<b>Simulation</b>				<u>Distance simulation mode:</u> 0 = No simulation 1 = Fix value 2 = Simulation with a manual value: PV=a entered in P86 3= Simulation between P86 and P87 levels with P85 cycle time (triangle wave) 4= Simulation between P86 and P87 levels with P85 cycle time (square wave)
85	<b>Cycle time of DIST simulation</b>	Cycle time of the distance simulation in seconds. Default value: 60 sec			
86	<b>Bottom value of the simulation</b>	Initial value of the distance simulation in the selected unit (e.g.: mm). Default value: 0 (mm)			
87	<b>Upper value of the simulation</b>	Final value of the distance simulation in the selected unit (e.g.: mm). Its default value is the same as the programmed maximal measurement range.			

# 8. MENU MAP

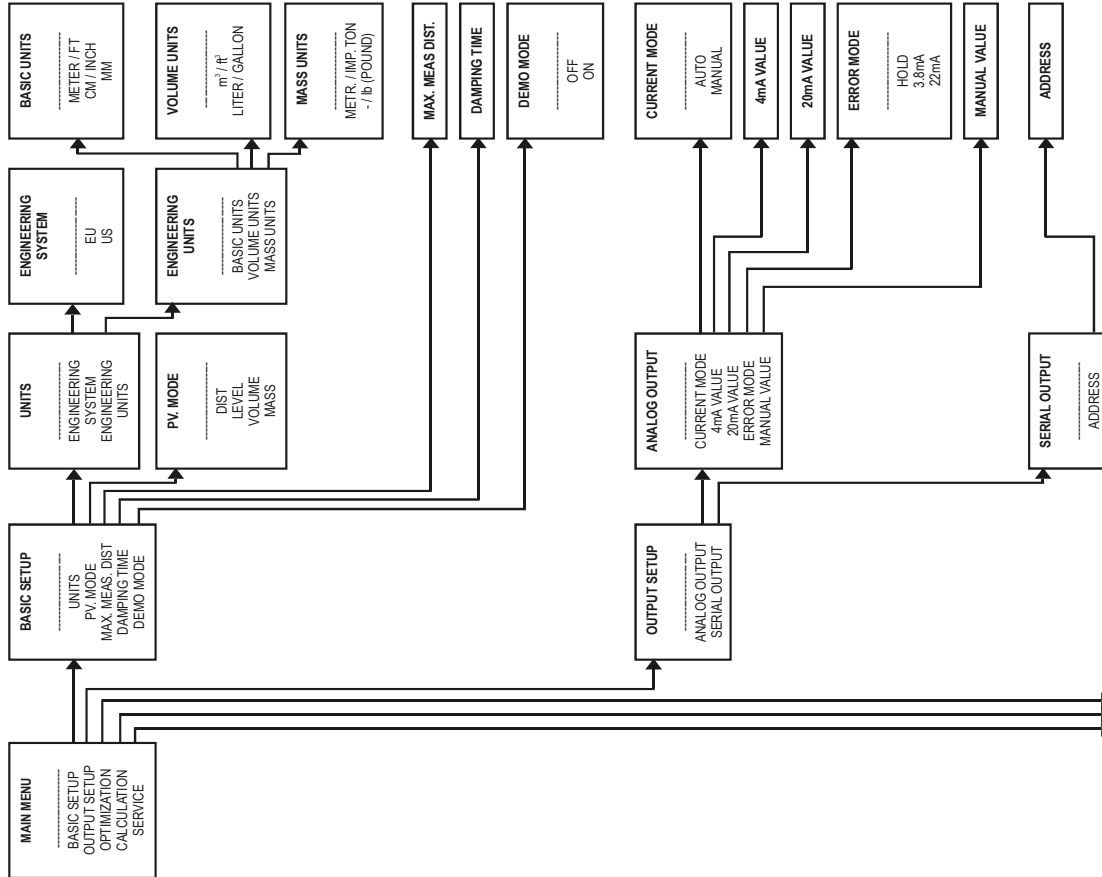

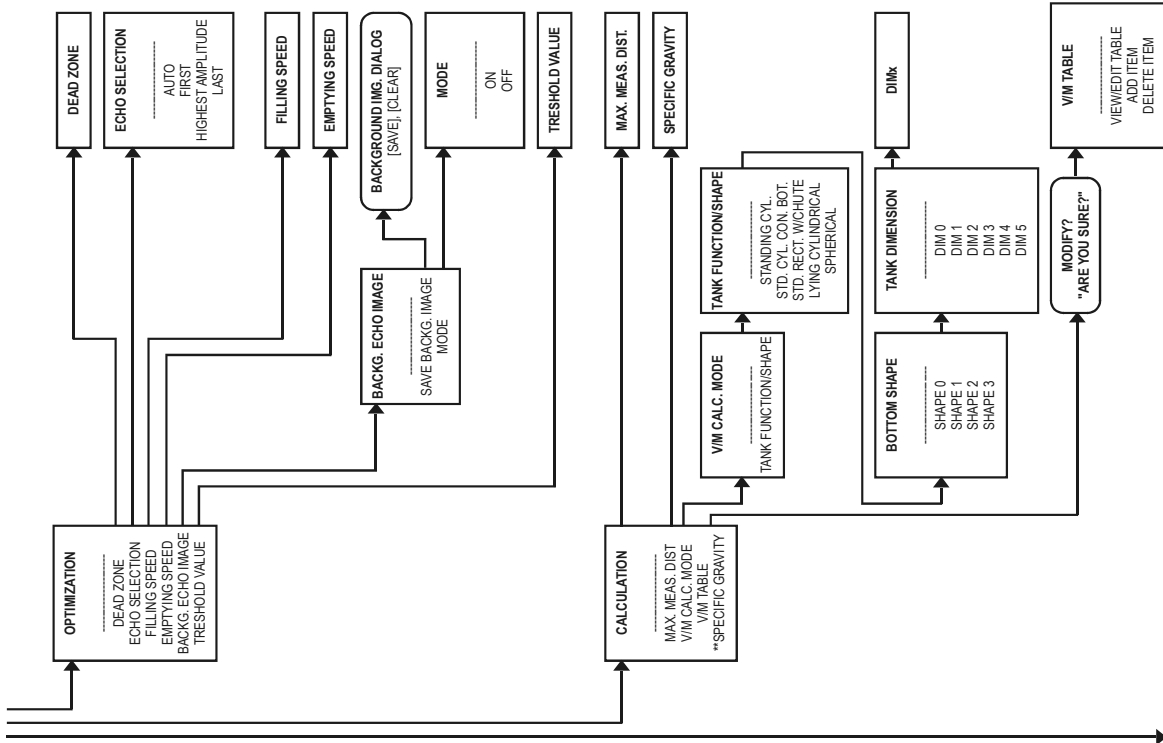

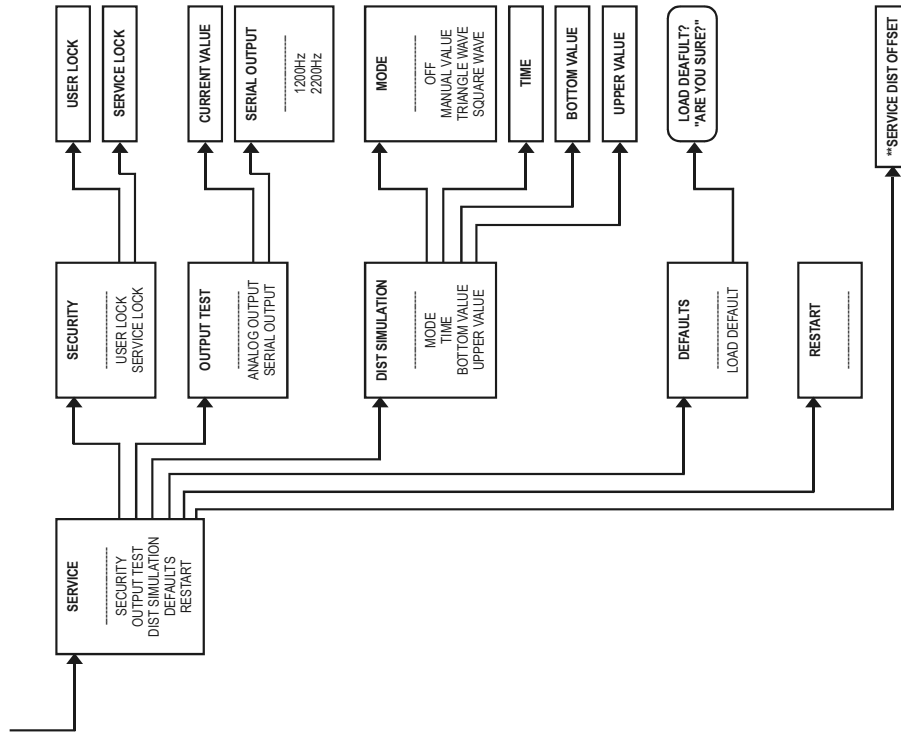

wes1404a0600p\_04.doc  
 2014. September  
 NIVELCO reserves the right to change technical data without notice!